

GD830F-24

Floor mount door retaining magnet with override button 24Vdc



This door retaining magnet is used to hold open doors that normally spring close. Can be linked to a fire alarm system to enable automatic closure of the door upon alarm signal. Ideal for schools, colleges, hospitals, hotels etc.

Features

- Floor mount
- Includes armature plate and fixings
- Complete with override button
- Metal housing
- Black powder coated finish
- Anti residual magnetism feature

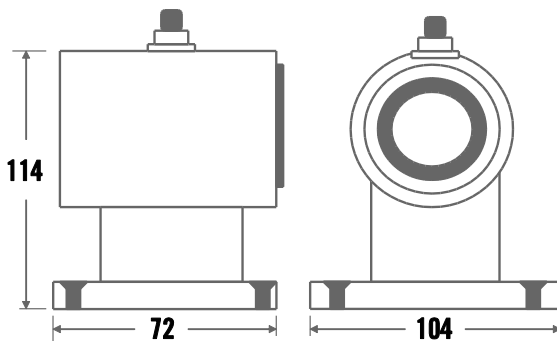

Technical Information

- Up to 36kg (80lb) holding force
- Voltage: 24Vdc
- Current: 60mA

Related Products

GD830S-24



GD830F-12



GD830S-12



DRM-135-24

