

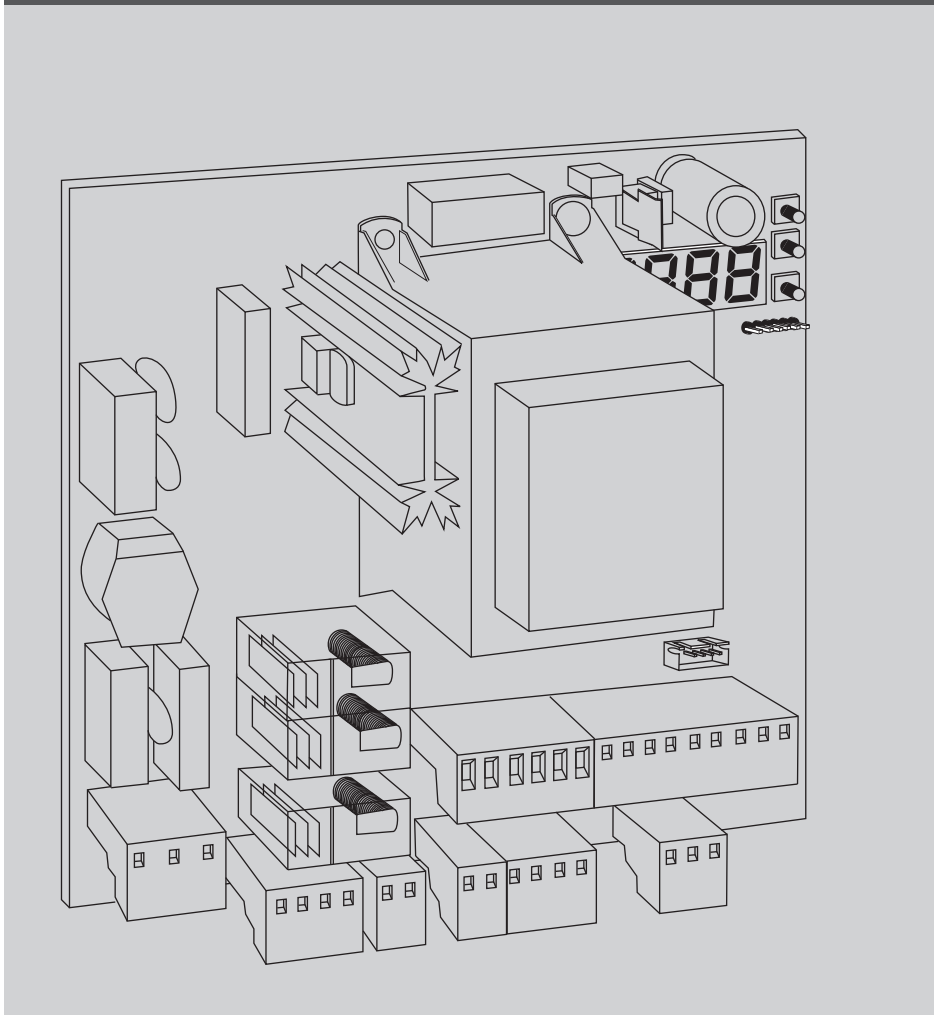

CONTROL PANEL



INSTALLATION MANUAL

LEO B CBB 3 230 L02
LEO B CBB 3 230 L04
LEO B CBB 3 120 F02
LEO B CBB 3 120 F04



AZIENDA CON SISTEMA DI GESTIONE
INTEGRATO CERTIFICATO DA DNV
= UNI EN ISO 9001:2008 =
UNI EN ISO 14001:2004



QUICK INSTALLATION

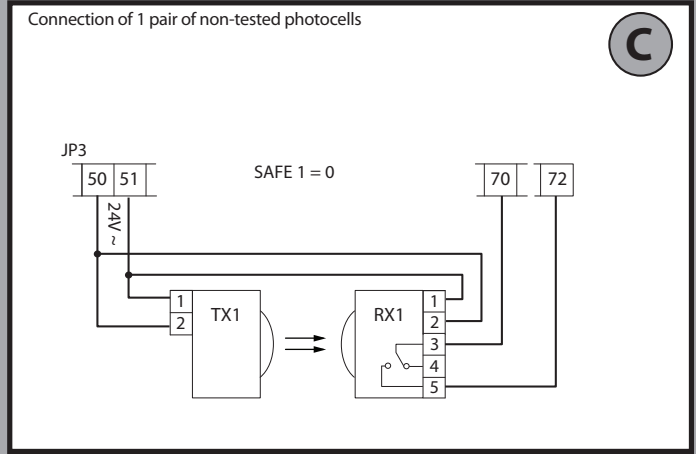
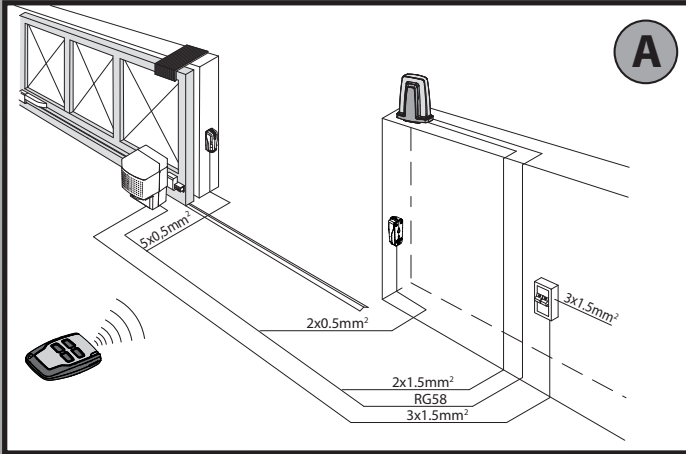

F1= 315mAT LEO B CBB 3 230 L02/L04
F1= 630mAT LEO B CBB 3 120 F02/F04

F2= 6,3 AF LEO B CBB 3 230 L02/L04
F2= 10 AF LEO B CBB 3 120 F02/F04

Display + programming keys

Palmtop programmer connector,

Radio-receiver connector (see relevant section).

Encoder connector

60 61 62 63 64 65

Commands

70 71 72 73 74 75 76 77 78

Safety devices

M	B	N
MARRONE	BLU	NERO
BROWN	BLUE	BLACK
MARRON	BLEU	NOIR
BRAUN	BLAU	SCHWARZ
MARRÓN	AZUL	NEGRO
BRUIN	BLAUW	ZWART

L N GND

Power supply

10 11 12 13

Motor

20 21

AUX

26 27

Limit switch inputs

40 41 42 43

Accessories power supply

50 51 52

Antenna

*** LEO B CBB 3 230 L02**
LEO B CBB 3 230 L04
LEO B CBB 3 120 F04
 AUX 3 MAX 24V 0,5A

AUX 3 = 0

AUX 3 = 1

*** LEO B CBB 3 120 F02**

ALARM
24 Vd.c.

ALARM

A B C D E

SOUND PATTERN SELECTION

VOLUME CONTROL

SOUND PATTERN SELECTION

1	CONTINUOUS	link	A
2	LONG PIP	link	A & E
3	SHORT PIP	link	A & D
4	SHRIEK 1	link	A B D
5	SHRIEK 2	link	A C E
6	WARBLE 1	link	A & B
7	WARBLE 2	link	A & C
8	TWO TONE 1	link	B
9	TWO TONE 2	link	C

**With reverse logic, opening direction = 000 (DIR=right)

SIMPLIFIED MENU

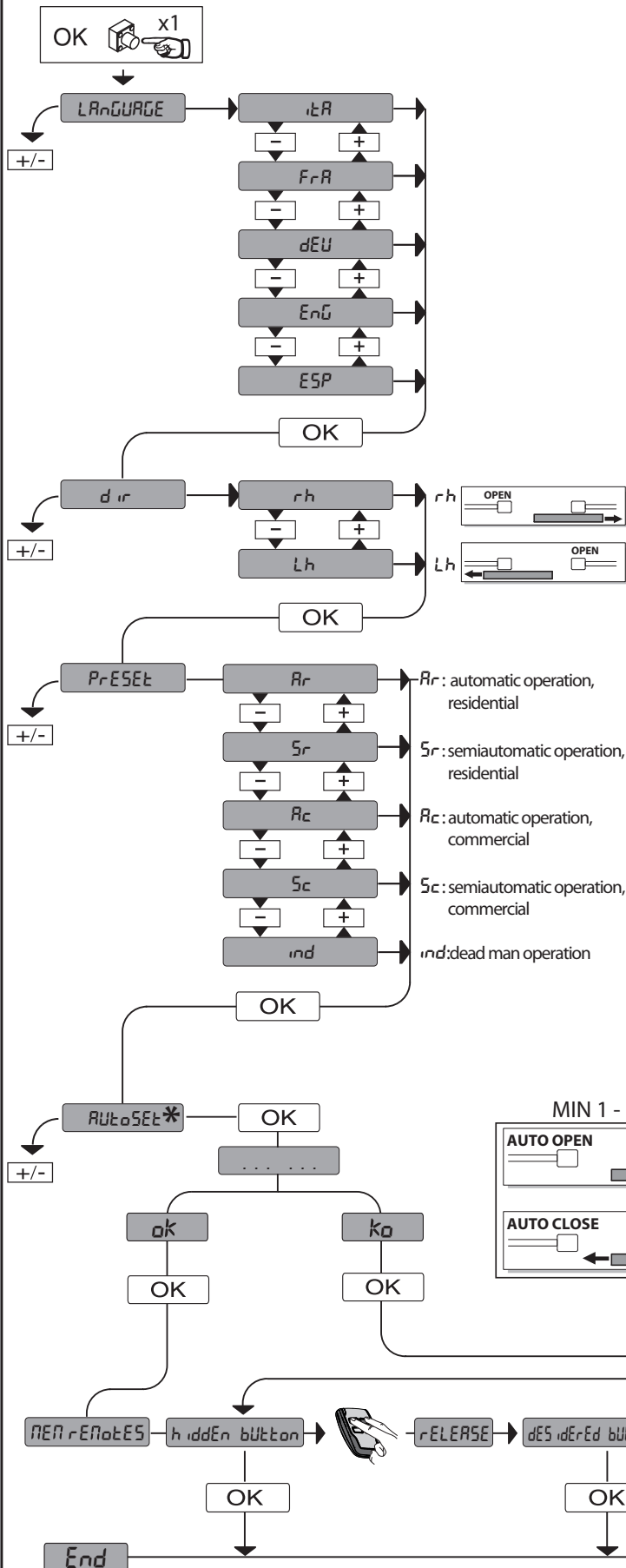

PRESET	DEFAULT	Rr	Sr	Rc	Sc	Ind
PARAMETERS						
Opening operation time [s]	300	Set by autose*				
Closing operation time [s]	300	Set by autose*				
Automatic closing time [s]	40	40	40	40	40	40
Time-to-clear traffic light zone [s]	40	40	40	40	40	40
Slow-down distance during opening [%]	30	Set by autose*				
Slow-down distance during closing [%]	30	Set by autose*				
Partial opening	20	20	20	20	20	20
Leaf force during opening [%]	41 (75***)	Set by autose*				
Leaf force during closing [%]	41 (75***)	Set by autose*				
Leaf/leaves force during opening during slow-down[%]	75	Set by autose*				
Leaf/leaves force during closing during slow-down [%]	75	Set by autose*				
Braking[%]	0	Set by autose*				
LOGIC						
Automatic Closing Time	0	1	0	1	0	0
Fast closing	0	0	0	0	0	0
Step-by-step movement	0	1	0	1	0	0
Encoder*	2**** 1*****	2**** 1*****	2**** 1*****	2**** 1*****	2**** 1*****	2**** 1*****
Pre-alarm	0	0	0	1	1	0
Deadman	0	0	0	0	0	1
Block pulses during opening	0	0	0	1	1	0
Block pulses during TCA	0	0	0	0	0	0
Block pulses during closing	0	0	0	0	0	0
Open in other direction	0	/	/	/	/	/
SAFE 1	0	/	/	/	/	/
SAFE 2	6	/	/	/	/	/
SAFE 3	2	/	/	/	/	/
IC 1	0	/	/	/	/	/
IC 2	4	/	/	/	/	/
IC 3	2	/	/	/	/	/
IC 4	3	/	/	/	/	/
AUX 3*	0	/	/	/	/	/
Fixed code	0	0	0	0	0	0
Transmitter programming	1	1	1	1	1	1
Serial mode	0	0	0	0	0	0
Address	0	0	0	0	0	0
EXPI1	1	/	/	/	/	/
EXPI2	0	/	/	/	/	/
EXPO1	11	/	/	/	/	/
EXPO2	11	/	/	/	/	/
Traffic light pre-flashing	0	0	0	0	0	0

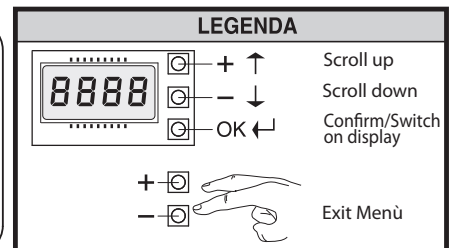
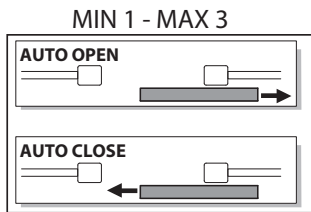

* Only active on LEO B CBB 3 230 L02
 ** Not active on LEO B CBB 3 120 F02
 *** Setup for LEO B CBB 3 120 F02, LEO B CBB 3 230 L04, LEO B CBB 3 120 F04

**** Setup for LEO B CBB 3 230 L02
 ***** Setup for LEO B CBB 3 120 F02

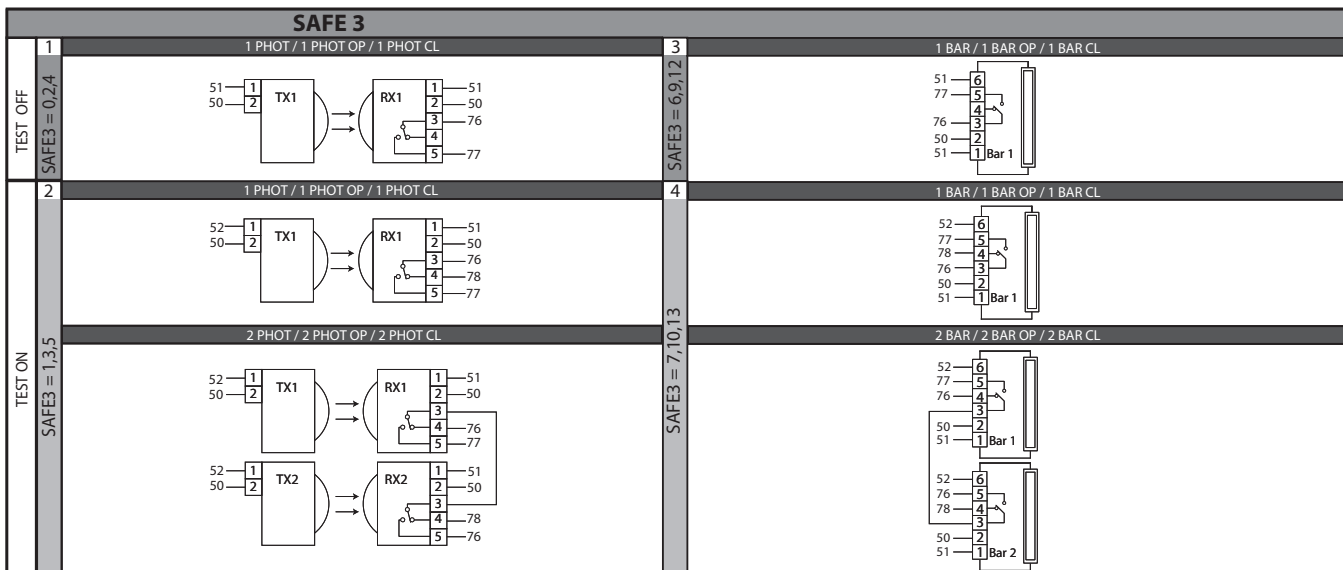
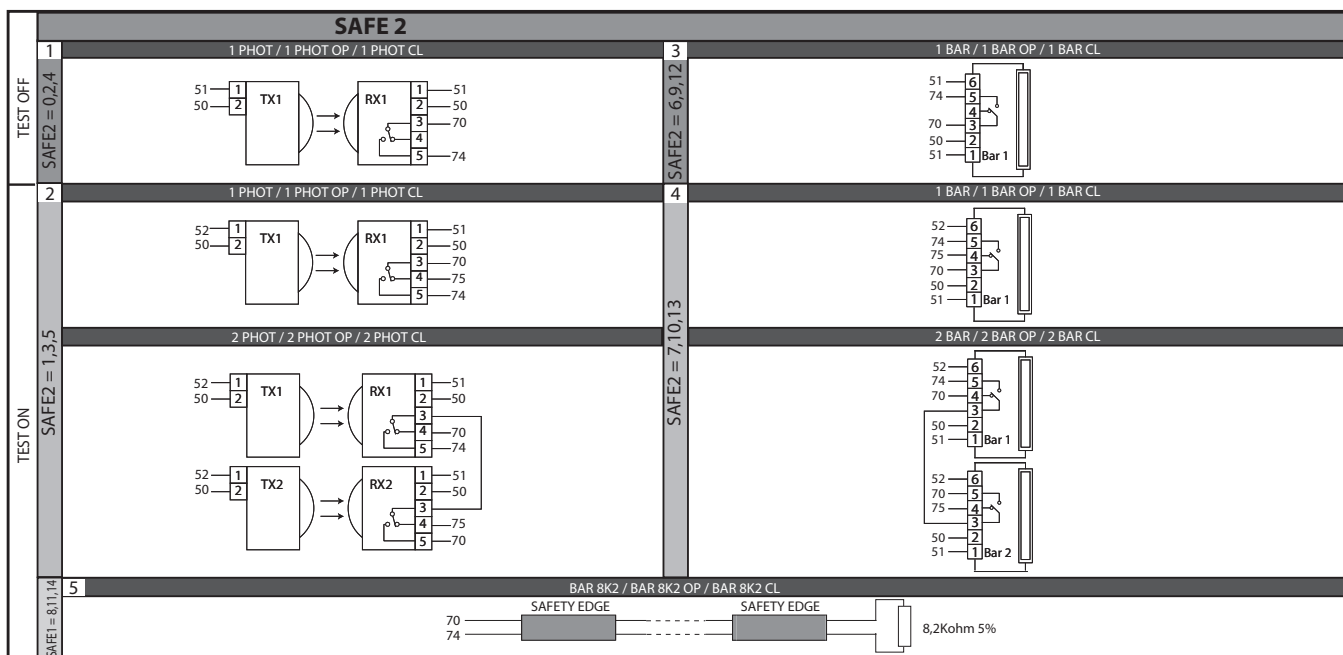
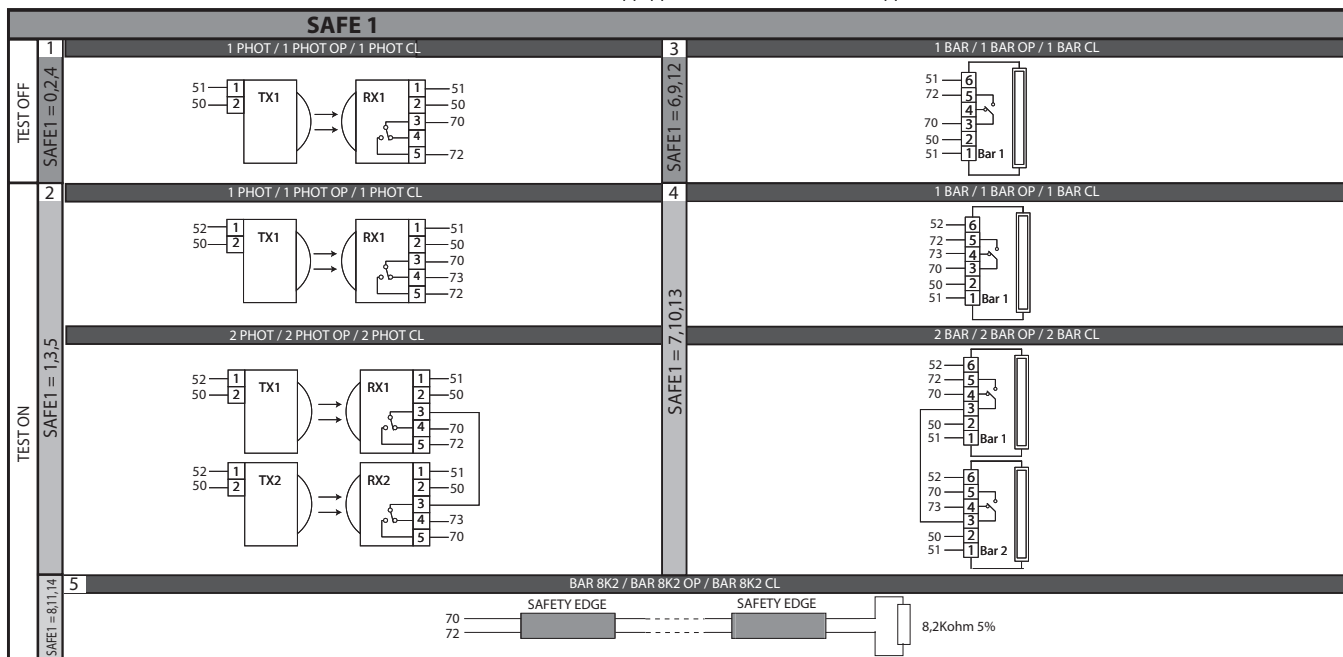
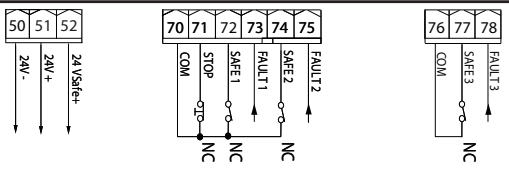

E

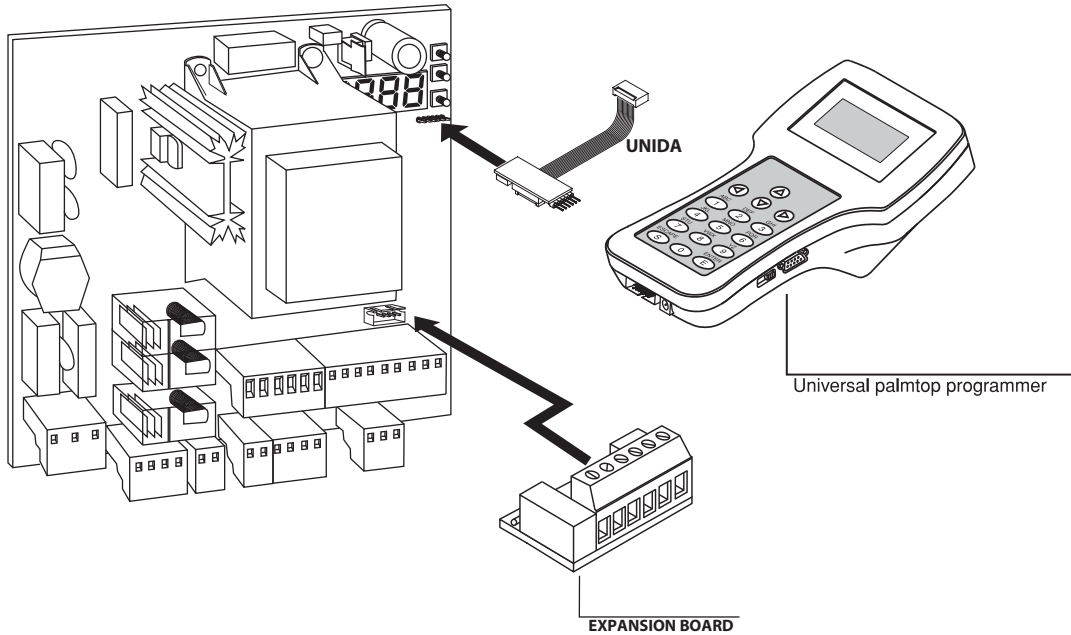

(x.40 and later versions)
(

RddrE55=0
SEr IRL PodE=3

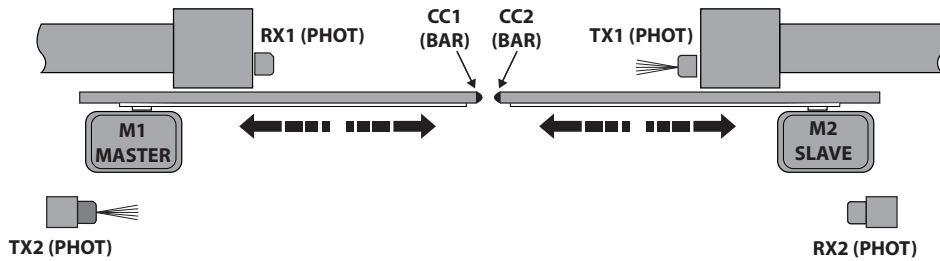

RddrE55=0
SEr IRL PodE=2

F

EXAMPLE APPLICATION WITH OPPOSITE LEAVES WITH 2 PHOT AND 2 BAR

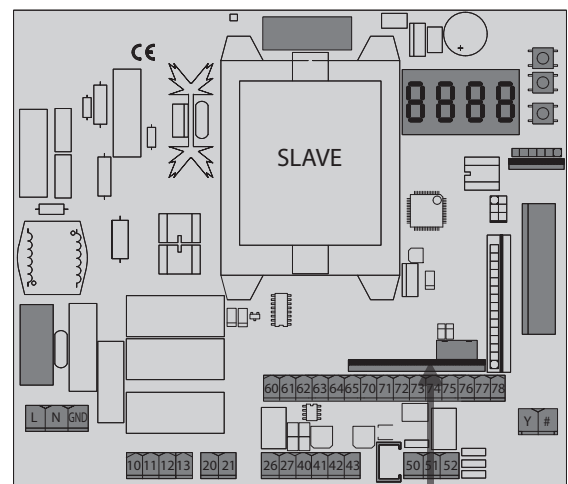
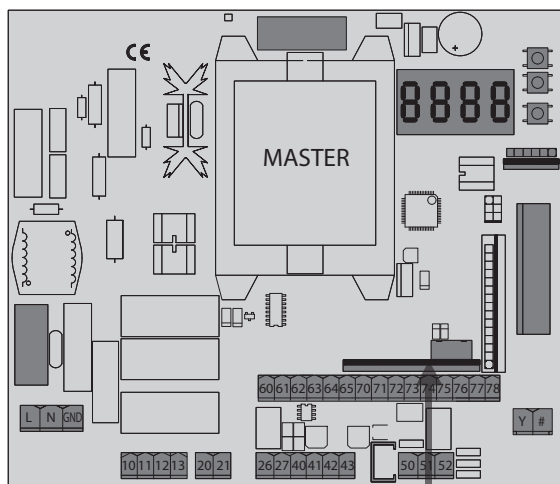

MAX 250m

B EBA 201 R01

B EBA 201 R01

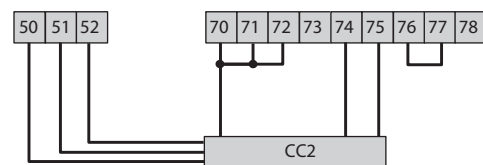
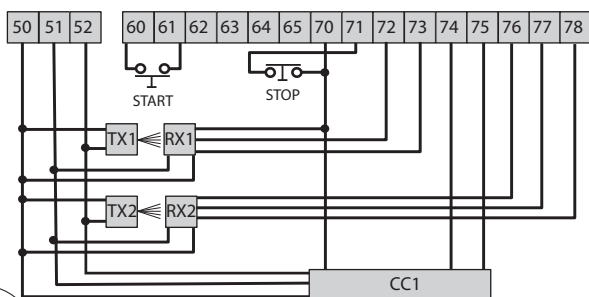

SAFE 2 SLAVE = SAFE 2 MASTER

SAFE 1 = 1
SAFE 2 = 7 (≥6)
SAFE 3 = 1

G

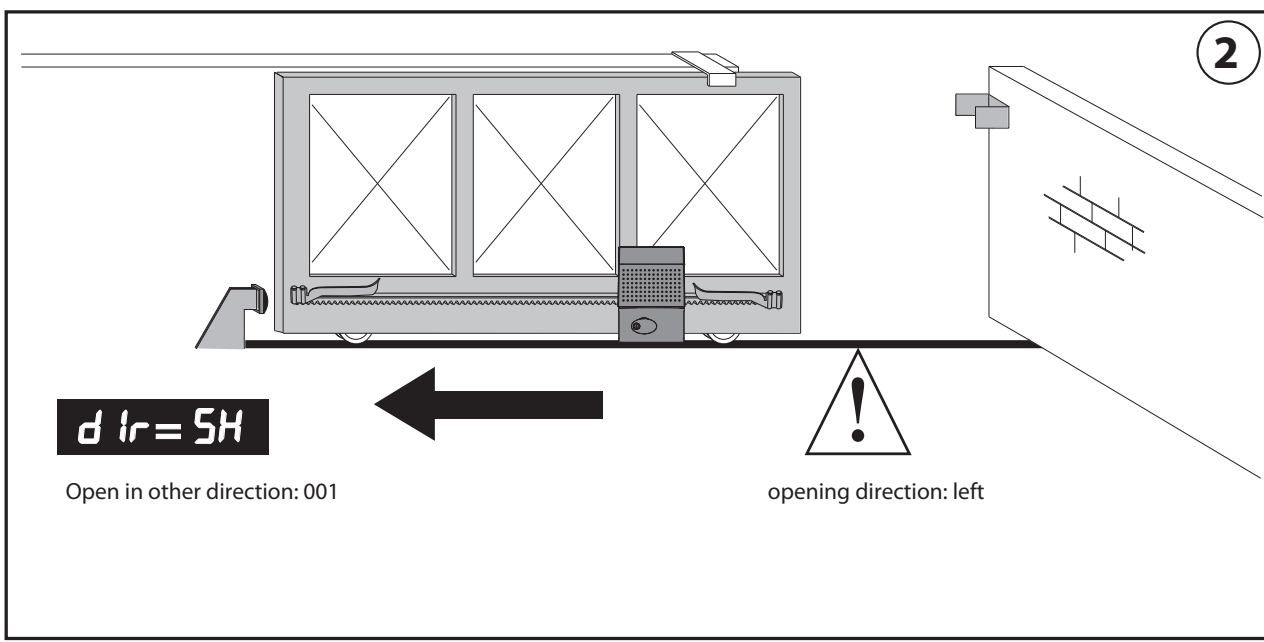
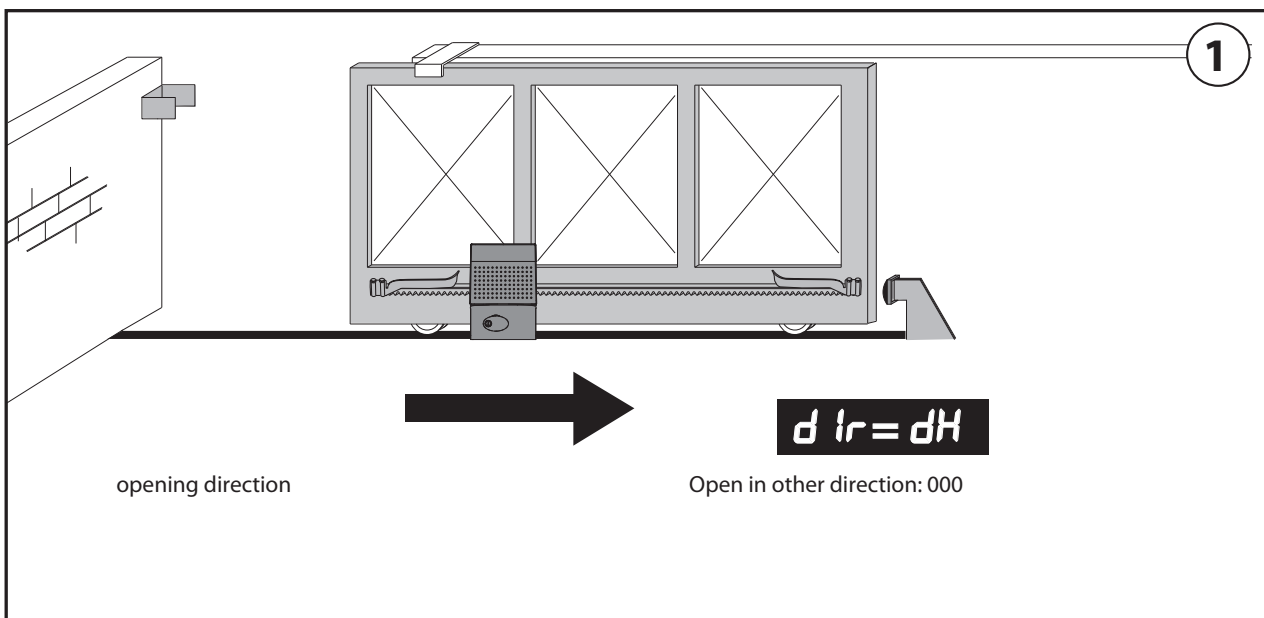

- When switching logic configuration from right to left opening, do not swap over original connection of terminals 42-43.

H

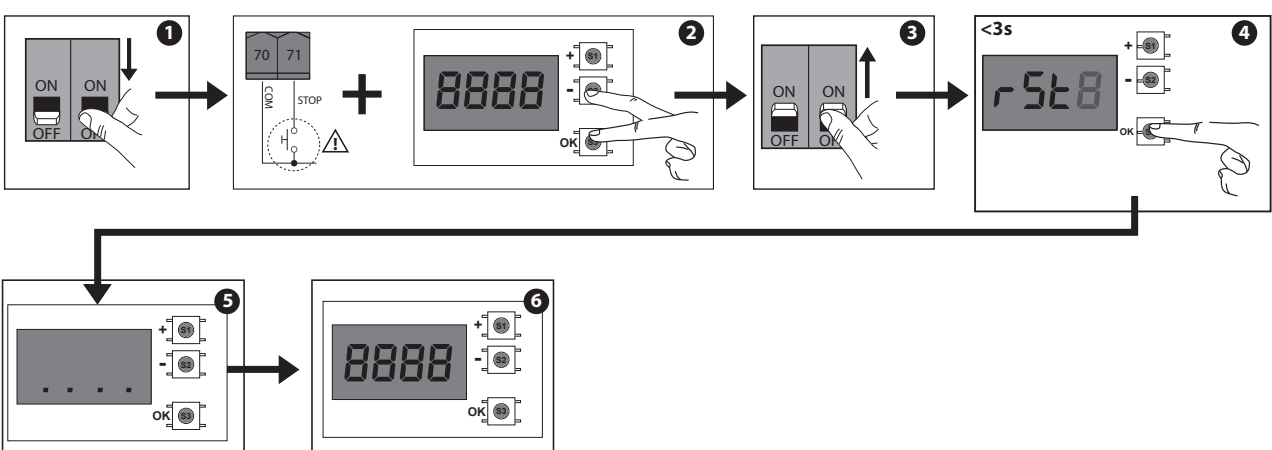

ACCESS MENUS Fig. 1

*** Password entry.
Request with Protection Level
logic set to 1, 2, 3, 4

LEGENDA

- Scroll up
- Scroll down
- Confirm/Switch on display
- Exit Menu

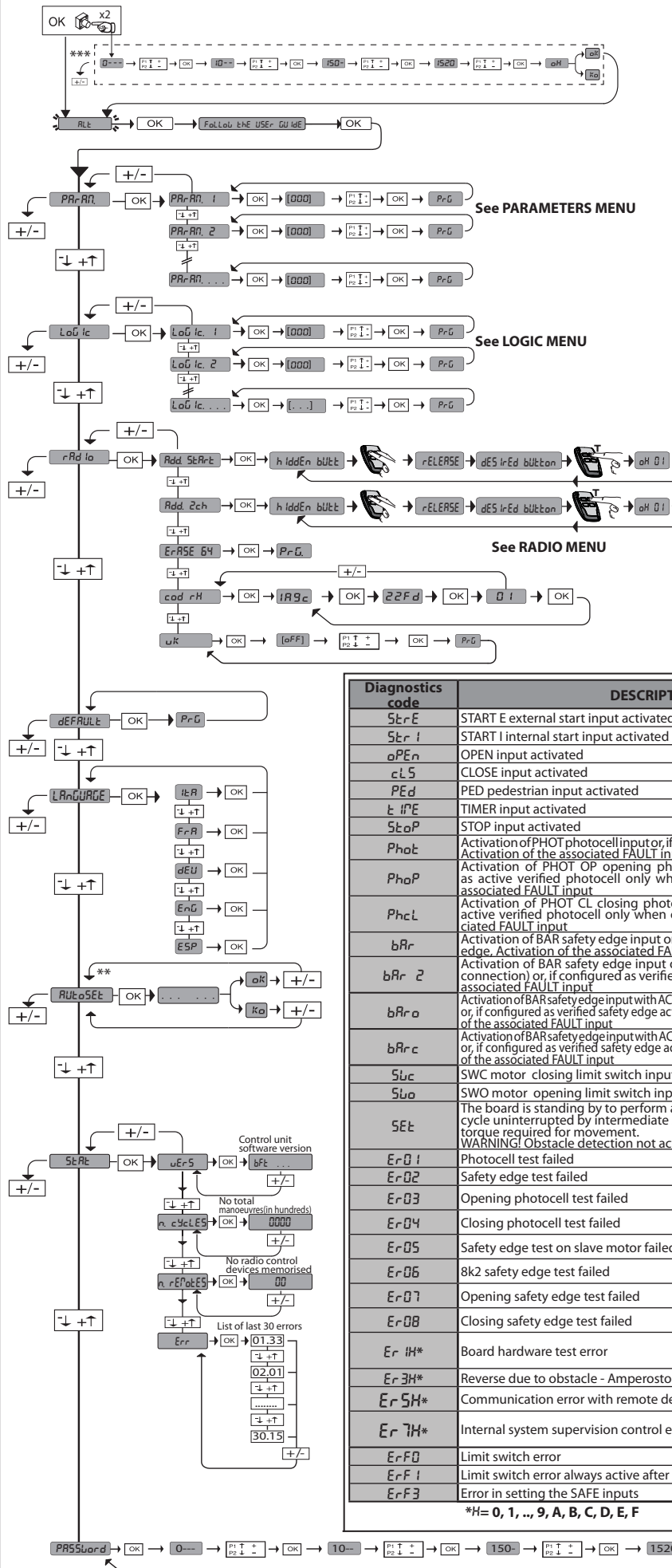

35.40 **

Obstacle threshold

Instantaneous force motor

Diagnostics code	DESCRIPTION	NOTES
StErE	START E external start input activated	
StEr I	START I internal start input activated	
oPEn	OPEN input activated	
cLS	CLOSE input activated	
PEd	PED pedestrian input activated	
t iPE	TIMER input activated	
StoP	STOP input activated	
PhoE	Activation of PHOT photocell input or, if configured as verified photocell, Activation of the associated FAULT input	
PhoP	Activation of PHOT OP opening photocell input or, if configured as active verified photocell only when opening, Activation of the associated FAULT input	
PhcL	Activation of PHOT CL closing photocell input or, if configured as active verified photocell only when closing, Activation of the associated FAULT input	
bRr	Activation of BAR safety edge input or, if configured as verified safety edge, Activation of the associated FAULT input	
bRr 2	Activation of BAR safety edge input on slave motor (opposing door connection) or, if configured as verified safety edge, Activation of the associated FAULT input	
bRr o	Activation of BAR safety edge input with ACTIVE reversal ONLY WHILE OPENING, or, if configured as verified safety edge active only while opening, Activation of the associated FAULT input	
bRr c	Activation of BAR safety edge input with ACTIVE reversal ONLY WHILE CLOSING, or, if configured as verified safety edge active only while closing, Activation of the associated FAULT input	
Sbc	SWC motor closing limit switch input activated	
Sbo	SWO motor opening limit switch input activated	
SEt	The board is standing by to perform a complete opening-closing cycle uninterrupted by intermediate stops in order to acquire the WARNING! Obstacle detection not active	
Er01	Photocell test failed	Check photocell connection and/or logic settings
Er02	Safety edge test failed	Check safety edge connection and/or logic settings
Er03	Opening photocell test failed	Check photocell connection and/or parameter/logic setting
Er04	Closing photocell test failed	Check photocell connection and/or parameter/logic setting
Er05	Safety edge test on slave motor failed (opposite leaves connection)	Check safety edge connection and/or parameter/logic settings
Er06	8k2 safety edge test failed	Check safety edge connection and/or parameter/logic settings
Er07	Opening safety edge test failed	Check safety edge connection and/or parameter/logic settings
Er08	Closing safety edge test failed	Check safety edge connection and/or parameter/logic settings
Er1H*	Board hardware test error	- Check connections to motor - Hardware problems with board (contact technical assistance)
Er3H*	Reverse due to obstacle - Amperestop	Check for obstacles in path
Er5H*	Communication error with remote devices	Check connection with serial-connected accessory devices and/or expansion boards
Er7H*	Internal system supervision control error.	Try switching the board off and back on again. If the problem persists, contact the technical assistance department.
ErFB	Limit switch error	check limit switch connections
ErF1	Limit switch error always active after operation start	Check limit switch and motor connections
ErF3	Error in setting the SAFE inputs	Check the setting of the SAFE inputs is correct

*H= 0, 1, ..., 9, A, B, C, D, E, F

** Only active on LEO B CBB 3 230 L02

INSTALLER WARNINGS

WARNING! Important safety instructions. Carefully read and comply with all the warnings and instructions that come with the product as incorrect installation can cause injury to people and animals and damage to property. The warnings and instructions give important information regarding safety, installation, use and maintenance. Keep hold of instructions so that you can attach them to the technical file and keep them handy for future reference.

GENERAL SAFETY

This product has been designed and built solely for the purpose indicated herein. Uses other than those indicated herein might cause damage to the product and create a hazard.

- The units making up the machine and its installation must meet the requirements of the following European Directives, where applicable: 2004/108/EC, 2006/95/EC, 2006/42/EC, 89/106/EC, 99/05/EC and later amendments. For all countries outside the EEC, it is advisable to comply with the standards mentioned, in addition to any national standards in force, to achieve a good level of safety.
- The Manufacturer of this product (hereinafter referred to as the "Firm") disclaims all responsibility resulting from improper use or any use other than that for which the product has been designed, as indicated herein, as well as for failure to apply Good Practice in the construction of entry systems (doors, gates, etc.) and for deformation that could occur during use.
- Installation must be carried out by qualified personnel (professional installer, according to EN 12635), in compliance with Good Practice and current code.
- Before installing the product, make all structural changes required to produce safety gaps and to provide protection from or isolate all crushing, shearing and dragging hazard areas and danger zones in general in accordance with the provisions of standards EN 12604 and 12453 or any local installation standards. Check that the existing structure meets the necessary strength and stability requirements.
- Before commencing installation, check the product for damage.
- The Firm is not responsible for failure to apply Good Practice in the construction and maintenance of the doors, gates, etc. to be motorized, or for deformation that might occur during use.
- Make sure the stated temperature range is compatible with the site in which the automated system is due to be installed.
- Do not install this product in an explosive atmosphere: the presence of flammable fumes or gas constitutes a serious safety hazard.
- Disconnect the electricity supply before performing any work on the system. Also disconnect buffer batteries, if any are connected.
- Before connecting the power supply, make sure the product's ratings match the mains ratings and that a suitable residual current circuit breaker and overcurrent protection device have been installed upline from the electrical system. Have the automated system's mains power supply fitted with a switch or omnipolar thermal-magnetic circuit breaker with a contact separation that provide full disconnection under overvoltage category III conditions.
- Make sure that upline from the mains power supply there is a residual current circuit breaker that trips at no more than 0.03A as well as any other equipment required by code.
- Make sure the earth system has been installed correctly: earth all the metal parts belonging to the entry system (doors, gates, etc.) and all parts of the system featuring an earth terminal.
- Installation must be carried out using safety devices and controls that meet standards EN 12978 and EN 12453.
- Impact forces can be reduced by using deformable edges.
- In the event impact forces exceed the values laid down by the relevant standards, apply electro-sensitive or pressure-sensitive devices.
- Apply all safety devices (photocells, safety edges, etc.) required to keep the area free of impact, crushing, dragging and shearing hazards. Bear in mind the standards and directives in force, Good Practice criteria, intended use, the installation environment, the operating logic of the system and forces generated by the automated system.
- Apply all signs required by current code to identify hazardous areas (residual risks). All installations must be visibly identified in compliance with the provisions of standard EN 13241-1.
- Once installation is complete, apply a nameplate featuring the door/gate's data.
- This product cannot be installed on leaves incorporating doors (unless the motor can be activated only when the door is closed).
- If the automated system is installed at a height of less than 2.5 m or is accessible, the electrical and mechanical parts must be suitably protected.
- For roller shutter automation only
 - 1) The motor's moving parts must be installed at a height greater than 2.5 m above the floor or other surface from which they may be reached.
 - 2) The gearmotor must be installed in a segregated and suitably protected space so that it cannot be reached without the aid of tools.
- Install any fixed controls in a position where they will not cause a hazard, away from moving parts. More specifically, hold-to-run controls must be positioned within direct sight of the part being controlled and, unless they are key operated, must be installed at a height of at least 1.5 m and in a place where they cannot be reached by the public.
- Apply at least one warning light (flashing light) in a visible position, and also attach a Warning sign to the structure.
- Attach a label near the operating device, in a permanent fashion, with information on how to operate the automated system's manual release.
- Make sure that, during operation, mechanical risks are avoided or relevant protective measures taken and, more specifically, that nothing can be banged, crushed, caught or cut between the part being operated and surrounding parts.
- Once installation is complete, make sure the motor automation settings are correct and that the safety and release systems are working properly.
- Only use original spare parts for any maintenance or repair work. The Firm disclaims all responsibility for the correct operation and safety of the automated system if parts from other manufacturers are used.
- Do not make any modifications to the automated system's components unless explicitly authorized by the Firm.
- Instruct the system's user on what residual risks may be encountered, on the control systems that have been applied and on how to open the system manually in an emergency. Give the user guide to the end user.

-Dispose of packaging materials (plastic, cardboard, polystyrene, etc.) in accordance with the provisions of the laws in force. Keep nylon bags and polystyrene out of reach of children.

WIRING

WARNING! For connection to the mains power supply, use a multicore cable with a cross-sectional area of at least 5x1.5mm² or 4x1.5mm² when dealing with three-phase power supplies or 3x1.5mm² for single-phase supplies (by way of example, type H05 VV-F cable can be used with a cross-sectional area of 4x1.5mm²). To connect auxiliary equipment, use wires with a cross-sectional area of at least 0.5 mm².

- Only use pushbuttons with a capacity of 10A-250V or more.
- Wires must be secured with additional fastening near the terminals (for example, using cable clamps) in order to keep live parts well separated from safety extra low voltage parts.
- During installation, the power cable must be stripped to allow the earth wire to be connected to the relevant terminal, while leaving the live wires as short as possible. The earth wire must be the last to be pulled taut in the event the cable's fastening device comes loose.

WARNING! safety extra low voltage wires must be kept physically separate from low voltage wires.

Only qualified personnel (professional installer) should be allowed to access live parts.

CHECKING THE AUTOMATED SYSTEM AND MAINTENANCE

Before the automated system is finally put into operation, and during maintenance work, perform the following checks meticulously:

- Make sure all components are fastened securely.
- Check starting and stopping operations in the case of manual control.
- Check the logic for normal or personalized operation.
- For sliding gates only: check that the rack and pinion mesh correctly with 2 mm of play along the full length of the rack; keep the track the gate slides on clean and free of debris at all times.
- For sliding gates and doors only: make sure the gate's running track is straight and horizontal and that the wheels are strong enough to take the weight of the gate.
- For cantilever sliding gates only: make sure there is no dipping or swinging during operation.
- For swing gates only: make sure the leaves' axis of rotation is perfectly vertical.
- For barriers only: before opening the door, the spring must be decompressed (vertical boom).
- Check that all safety devices (photocells, safety edges, etc.) are working properly and that the anti-crush safety device is set correctly, making sure that the force of impact measured at the points provided for by standard EN 12445 is lower than the value laid down by standard EN 12453.
- Impact forces can be reduced by using deformable edges.
- Make sure that the emergency operation works, where this feature is provided.
- Check opening and closing operations with the control devices applied.
- Check that electrical connections and cabling are intact, making extra sure that insulating sheaths and cable glands are undamaged.
- While performing maintenance, clean the photocells' optics.
- When the automated system is out of service for any length of time, activate the emergency release (see "EMERGENCY OPERATION" section) so that the operated part is made idle, thus allowing the gate to be opened and closed manually.
- If the power cord is damaged, it must be replaced by the manufacturer or their technical assistance department or other such qualified person to avoid any risk.
- If "D" type devices are installed (as defined by EN12453), connect in unverified mode, foresee mandatory maintenance at least every six months
- The maintenance described above must be repeated at least once yearly or at shorter intervals where site or installation conditions make this necessary.

WARNING!

Remember that the drive is designed to make the gate/door easier to use and will not solve problems as a result of defective or poorly performed installation or lack of maintenance



SCRAPPING

Materials must be disposed of in accordance with the regulations in force. Do not throw away your discarded equipment or used batteries with household waste. You are responsible for taking all your waste electrical and electronic equipment to a suitable recycling centre.

DISMANTLING

If the automated system is being dismantled in order to be reassembled at another site, you are required to:

- Cut off the power and disconnect the whole electrical system.
- Remove the actuator from the base it is mounted on.
- Remove all the installation's components.
- See to the replacement of any components that cannot be removed or happen to be damaged.

**DECLARATIONS OF CONFORMITY CAN BE FOUND AT <http://www.bft-automation.com/CE>
INSTRUCTIONS FOR USE AND ASSEMBLY CAN BE FOUND IN THE DOWN-LOAD SECTION.**

Anything that is not explicitly provided for in the installation manual is not allowed. The operator's proper operation can only be guaranteed if the information given is complied with. The Firm shall not be answerable for damage caused by failure to comply with the instructions featured herein.

While we will not alter the product's essential features, the Firm reserves the right, at any time, to make those changes deemed opportune to improve the product from a technical, design or commercial point of view, and will not be required to update this publication accordingly.

INSTALLATION MANUAL

2) GENERAL INFORMATION

The **LEO B CBB 3 230 L02 - LEO B CBB 3 230 L04 - LEO B CBB 3 120 F02 - LEO B CBB 3 120 F04** control panel comes with standard factory settings. Any change must be made using the programmer with built-in display or universal handheld programmer. The Control unit completely supports the EELINK protocol.

Its main features are:

- Control of 1 single-phase motor
- Electronic torque control
- Obstacle detection (only on LEO B CBB 3 230 L02 e LEO B CBB 3 120 F02)
- Separate inputs for safety devices
- Configurable command inputs
- Built-in radio receiver rolling code with transmitter cloning.

The board has a terminal strip of the removable kind to make maintenance or replacement easier. It comes with a series of prewired jumpers to make the installer's job on site easier.

The jumpers concern terminals: 70-71, 70-72, 70-74, 76-77. If the above-mentioned terminals are being used, remove the relevant jumpers.

	LEO B CBB 3 230 L02	LEO B CBB 3 120 F02	LEO B CBB 3 230 L04	LEO B CBB 3 120 F04
Power supply	230V~ ±10% 50Hz/60Hz	120V~ ±10% 50Hz/60Hz	230V~ ±10% 50Hz/60Hz	120V~ ±10% 50Hz/60Hz
Obstacle detection with encoder	Present	Present	Not present	Not present
Output for terminals 26-27: N.O. contact (24V~/0,5A)	AUX3 configurable	Output for audible signal	AUX3 configurable	AUX3 configurable

TESTING

The **LEO B CBB 3 230 L02 - LEO B CBB 3 230 L04 - LEO B CBB 3 120 F02 - LEO B CBB 3 120 F04** panel controls (checks) the start relays and safety devices (photocells) before performing each opening and closing cycle.

If there is a malfunction, make sure that the connected devices are working properly and check the wiring.

WIRING AND TERMINAL BOARD CONFIGURATION

	Terminal	Definition	Description
Power supply	L	LINE	Single-phase power supply 230V~ ±10%, 50-60Hz, with earth cable (LEO B CBB 3 230 L02, LEO B CBB 3 230 L04).
	N	NEUTRAL	
	GND	EARTH	Single-phase power supply 120V~ ±10%, 50-60Hz, with earth cable (LEO B CBB 3 120 F02, LEO B CBB 3 120 F04).
Motor	10	START + CAP	Motor connection. START + CAP Motor Start and capacitor COM Motor Common START MOTOR START CAP capacitor
	11	COM	
	12	START	
	13	CAP	
Aux	20	LIGHT 230V	Flashing light 230V output max. 40W (LEO B CBB 3 230 L02, LEO B CBB 3 230 L04).
	21		Flashing light 120V output max. 40W (LEO B CBB 3 120 F02, LEO B CBB 3 120 F04).
	26	AUX3 - FREE CONTACT (N.O.) (Max 24V 1A)	Contact N.O. (24V~/1A). "AUX3" (LEO B CBB 3 230 L02, LEO B CBB 3 230 L04, LEO B CBB 3 120 F04) FIG. B1 Output for acoustic signal (LEO B CBB 3 120 F02) FIG. B2
Motor 1 limit switch	41	+ REF SWE	Limit switch common
	42	SWC	Closing limit switch SWC (N.C.)
	43	SWO	- Opening limit switch SWO (N.C.)
Accessories power supply	50	24V-	Accessories power supply output.
	51	24V+	
	52	24 Vsafe+	Tested safety device power supply output (photocell transmitter and safety edge transmitter). Output active only during operating cycle.
Commands	60	Common	IC 1 and IC 2 inputs common
	61	IC 1	Configurable command input 1 (N.O.) - Default START E. START E / START I / OPEN / CLOSE / PED / TIMER / TIMER PED Refer to the "Command input configuration" table.
	62	IC 2	Configurable command input 2 (N.O.) - Default PED. START E / START I / OPEN / CLOSE / PED / TIMER / TIMER PED Refer to the "Command input configuration" table.
	63	Common	IC 3 and IC 4 inputs common
	64	IC 3	Configurable command input 3 (N.O.) - Default OPEN. START E / START I / OPEN / CLOSE / PED / TIMER / TIMER PED Refer to the "Command input configuration" table.
	65	IC 4	Configurable command input 4 (N.O.) - Default CLOSE. START E / START I / OPEN / CLOSE / PED / TIMER / TIMER PED Refer to the "Command input configuration" table.

3) TECHNICAL SPECIFICATIONS

Power supply	230V~ ±10% 50Hz/60Hz (LEO B CBB 3 230 L02, LEO B CBB 3 230 L04)
	120V~ ±10% 50Hz/60Hz (LEO B CBB 3 120 F02, LEO B CBB 3 120 F04)
Low voltage/mains insulation	> 2MOhm 500V
Operating temperature range	-20 / +55°C
Thermal overload protection	Built into motor
Dielectric rigidity	mains/LV 3750V~ for 1 minute
Maximum motor power	750W
Accessories power supply	24V~ (demand max. 1A) 24V~safe
AUX 3/ Output for audible signal	NO contact (24V~/max.0,5A)
Flashing light	230V~ 40W max
Dimensions	146x170x60mm
Fuses	see Fig. B
N° of combinations	4 billion
Max.n° of transmitters that can be memorized	63

Usable transmitter versions:

All ROLLING CODE transmitters compatible with ((€R-Ready))

4) TUBE ARRANGEMENT Fig. A

5) TERMINAL BOARD WIRING Fig. B

WARNINGS - When performing wiring and installation, refer to the standards in force and, whatever the case, apply good practice principles.

Wires carrying different voltages must be kept physically separate from each other, or they must be suitably insulated with at least 1mm of additional insulation. Wires must be secured with additional fastening near the terminals, using devices such as cable clamps.

All connecting cables must be kept far enough away from the dissipater.

INSTALLATION MANUAL

WIRING AND TERMINAL BOARD CONFIGURATION

	Terminal	Definition	Description
Safety devices	70	Common	STOP, SAFE 1 and SAFE 2 inputs common
	71	STOP	The command stops movement. (N.C.) If not used, leave jumper inserted.
	72	SAFE 1	Configurable safety input 1 (N.C.) - Default PHOT. PHOT / PHOT TEST / PHOT OP / PHOT OP TEST / PHOT CL / PHOT CL TEST / BAR / BAR TEST / BAR 8K2 / BAR OP / BAR OP TEST / BAR 8K2 OP / BAR CL / BAR CL TEST / BAR 8K2 CL Refer to the "Safety input configuration" table.
	73	FAULT 1	Test input for safety devices connected to SAFE 1.
	74	SAFE 2	Configurable safety input 2 (N.C.) - Default BAR. PHOT / PHOT TEST / PHOT OP / PHOT OP TEST / PHOT CL / PHOT CL TEST / BAR / BAR TEST / BAR 8K2 / BAR OP / BAR OP TEST / BAR 8K2 OP / BAR CL / BAR CL TEST / BAR 8K2 CL Refer to the "Safety input configuration" table.
	75	FAULT 2	Test input for safety devices connected to SAFE 2.
	76	Common	SAFE 3 input common
	77	SAFE 3	Configurable safety input 3 (N.C.) - Default PHOT OP. PHOT / PHOT TEST / PHOT OP / PHOT OP TEST / PHOT CL / PHOT CL TEST / BAR / BAR TEST / BAR OP / BAR OP TEST / BAR CL / BAR CL TEST. Refer to the "Safety input configuration" table.
Antenna	Y	ANTENNA	Antenna input. Use an antenna tuned to 433MHz. Use RG58 coax cable to connect the Antenna and Receiver. Metal bodies close to the antenna can interfere with radio reception. If the transmitter's range is limited, move the antenna to a more suitable position.
	#	SHIELD	

AUX output configuration (Not active on LEO B CBB 3 120 F02)

Aux logic= 0 - 2ND RADIO CHANNEL output. Contact stays closed for 1s when 2nd radio channel is activated.
Aux logic= 1 - SCA GATE OPEN LIGHT output. Contact stays closed during opening and with leaf open, intermittent during closing, open with leaf closed.
Aux logic= 2 - COURTESY LIGHT command output. Contact stays on for 90 seconds after the last operation.
Aux logic= 3 - ZONE LIGHT command output. Contact stays closed for the full duration of operation.
Aux logic= 4 - STAIR LIGHT output. Contact stays closed for 1 second at start of operation.
Aux logic= 5 - GATE OPEN ALARM output. Contact stays closed if the leaf stays open for double the set TCA time.
Aux logic= 6 - FLASHING LIGHT output. Contact stays closed while leaves are operating.
Aux logic= 7 - SOLENOID LATCH output. Contact stays closed for 2 seconds each time gate is opened.
Aux logic= 8 - MAGNETIC LOCK output. Contact stays closed while gate is closed.
Aux logic= 9 - MAINTENANCE output. Contact stays closed once the value set for the Maintenance parameter is reached, to report that maintenance is required.
Aux logic= 10 - FLASHING LIGHT AND MAINTENANCE output. Contact stays closed while leaves are operating. If the value set for the Maintenance parameter is reached, once the gate has finished moving and the leaf is closed, the contact closes for 10 sec. and opens for 5 sec. 4 times to report that maintenance is required.
Aux Logic= 11 - Not used

Command input configuration

IC logic= 0 - Input configured as Start E. Operation according to 5tEP-by-5tEP P _{au} . logic. External start for traffic light control.
IC logic= 1 - Input configured as Start I. Operation according to 5tEP-by-5tEP P _{au} . logic. Internal start for traffic light control.
IC logic= 2 - Input configured as Open. The command causes the leaves to open. If the input stays closed, the leaves stay open until the contact is opened. When the contact is open, the automated device closes following the TCA time, where activated.
IC logic= 3 - Input configured as Closed. The command causes the leaves to close.
IC logic= 4 - Input configured as Ped. The command causes the leaf to open to the pedestrian (partial) opening position. Operation according to 5tEP-by-5tEP. logic
IC logic= 5 - Input configured as Timer. Operation same as open except closing is guaranteed even after a mains power outage.
IC logic= 6 - Input configured as Timer Ped. The command causes the leaf to open to the pedestrian (partial) opening position. If the input stays closed, the leaf stays open until the contact is opened. If the input stays closed and a Start E, Start I or Open command is activated, a complete opening-closing cycle is performed before returning to the pedestrian opening position. Closing is guaranteed even after a mains power outage.

Safety input configuration

SAFE logic= 0 - Input configured as Phot (photocell) non tested (*) (fig.D, ref.1). Enables connection of devices not equipped with supplementary test contacts. When beam is broken, photocells are active during both opening and closing. When beam is broken during closing, movement is reversed only once the photocell is cleared. If not used, leave jumper inserted.
SAFE logic= 1 - Input configured as Phot test (tested photocell). (fig.D, ref.2). Switches photocell testing on at start of operation. When beam is broken, photocells are active during both opening and closing. When beam is broken during closing, movement is reversed only once the photocell is cleared.
SAFE logic= 2 - Input configured as Phot op (photocell active during opening only) non tested (*) (fig.D, ref.1). Enables connection of devices not equipped with supplementary test contacts. In the event beam is broken, photocell operation is disabled during closing. During opening, stops motion for as long as the photocell beam stays broken. If not used, leave jumper inserted.
SAFE logic= 3 - Input configured as Phot op test (tested photocell active during opening only) (fig.D, ref.2). Switches photocell testing on at start of operation. In the event beam is broken, photocell operation is disabled during closing. During opening, stops motion for as long as the photocell beam stays broken.
SAFE logic= 4 - Input configured as Phot cl (photocell active during closing only) non tested (*) (fig.D, ref.1). Enables connection of devices not equipped with supplementary test contacts. In the event beam is broken, photocell operation is disabled during opening. During closing, movement is reversed immediately. If not used, leave jumper inserted.
SAFE logic= 5 - Input configured as Phot cl test (tested photocell active during closing only) (fig.D, ref.2). Switches photocell testing on at start of operation. In the event beam is broken, photocell operation is disabled during opening. During closing, movement is reversed immediately.
SAFE logic= 6 - Input configured as Bar (safety edge) non tested (*) (fig.D, ref.3). Enables connection of devices not equipped with supplementary test contacts. The command reverses movement for 2 sec.. If not used, leave jumper inserted.
SAFE logic= 7 - Input configured as Bar (tested safety edge) (fig.D, ref.4). Switches safety edge testing on at start of operation. The command reverses movement for 2 sec.
SAFE logic= 8 - Input configured as Bar 8k2 (fig.D, ref.5). Input for resistive edge 8K2. The command reverses movement for 2 sec..
SAFE logic=9 Input configured as Bar op, safety edge with active inversion only while opening, if activated while closing, the automation stops (STOP) (Fig. D, ref. 3). Allows connecting devices not fitted with supplementary test contact. The operation while opening causes the movement to be reversed for 2 seconds, the operation while closing causes the automation to stop. If not used, leave jumper inserted.
SAFE logic=10 Input configured as Bar op test, safety edge checked with active inversion only while opening, if activated while closing, the automation stops (STOP) (Fig. D, ref. 4). Activates testing safety edges when starting operation. The operation while opening causes the movement to be reversed for 2 seconds, the operation while closing causes the automation to stop.
SAFE logic=11 Input configured as Bar 8k2 op, 8k2 safety edge with active inversion only while opening, if activated while closing, the automation stops (STOP) (Fig. D, ref. 5). The operation while opening causes the movement to be reversed for 2 seconds, the operation while closing causes the automation to stop.
SAFE logic=12 Input configured as Bar cl, safety edge with active inversion only while closing, if activated while opening, the automation stops (STOP) (Fig. D, ref. 3). Allows connecting devices not fitted with supplementary test contact. The operation while closing causes the movement to be reversed for 2 seconds, the operation while opening causes the automation to stop. If not used, leave jumper inserted.
SAFE logic=13 Input configured as Bar cl test, safety edge checked with active inversion only while closing, if activated while opening, the automation stops (STOP) (Fig. D, ref. 4). Activates testing safety edges when starting operation. The operation while closing causes the movement to be reversed for 2 seconds, the operation while opening causes the automation to stop.
SAFE logic=14 Input configured as Bar 8k2 cl, safety edge with active inversion only while closing, if activated while opening, the automation stops (STOP) (Fig. D, ref. 5). The operation while closing causes the movement to be reversed for 2 seconds, the operation while opening causes the automation to stop.

(*) If "D" type devices are installed (as defined by EN12453), connect in unverified mode, foresee mandatory maintenance at least every six months.

6) SAFETY DEVICES

Note: only use receiving safety devices with free changeover contact.

6.1) TESTED DEVICES Fig. D

6.2) CONNECTION OF 1 PAIR OF NON-TESTED PHOTOCELLS FIG. C

7) CALLING UP MENUS: FIG. 1

7.1) PARAMETERS MENU (PRr Rr) (PARAMETERS TABLE "A")

7.2) LOGIC MENU (L o G l c) (LOGIC TABLE "B")

7.3) RADIO MENU (r R d i o) (RADIO TABLE "C")

IMPORTANT NOTE: THE FIRST TRANSMITTER MEMORIZED MUST BE IDENTIFIED BY ATTACHING THE KEY LABEL (MASTER).

In the event of manual programming, the first transmitter assigns the RECEIVER'S KEY CODE: this code is required to subsequently clone the radio transmitters.

The Clonix built-in on-board receiver also has a number of important advanced features:

- Cloning of master transmitter (rolling code or fixed code).
- Cloning to replace transmitters already entered in receiver.
- Transmitter database management.
- Receiver community management.

To use these advanced features, refer to the universal handheld programmer's instructions and to the general receiver programming guide.

7.4) DEFAULT MENU (d E F A U L T)

Restores the controller's DEFAULT factory settings. Following this reset, you will need to run the AUTOSET function again.

7.5) LANGUAGE MENU (L A N G U A G E)

Used to set the programmer's language on the display.

7.6) AUTOSET MENU (R U T o S E T)

(ONLY ACTIVE ON LEO B CBB 3 230 L02)

- Launch an autose operation by going to the relevant menu.
- As soon as you press the OK button, the "..... .." message is displayed and the control unit commands the device to perform a full cycle (opening followed by closing), during which the minimum torque value required to move the leaf is set automatically. The number of cycles required for the autose function can range from 1 to 3. During this stage, it is important to avoid breaking the photocells' beams and not to use the START and STOP commands or the display. Once this operation is complete, the control unit will have automatically set the optimum force values, slow-down distances and operation times. Check them and, where necessary, edit them as described in the programming section.

WARNING!! Check that the force of impact measured at the points provided for by standard EN 12445 is lower than the value laid down by standard EN 12453.

Impact forces can be reduced by using deformable edges.

Warning!! While the autose function is running, the obstacle detection function is not active. Consequently, the installer must monitor the automated system's movements and keep people and property out of range of the automated system.

INSTALLATION TEST PROCEDURE

1. Run the AUTOSET cycle (*)
2. Check the impact forces: if they fall within the limits (**) skip to point 10, otherwise
3. Where necessary, adjust the sensitivity (force) parameters: see parameters table.
4. Check the impact forces again: if they fall within the limits (**) skip to point 10, otherwise
5. Apply a shock absorber profile
6. Check the impact forces again: if they fall within the limits (**) skip to point 10, otherwise
7. Apply pressure-sensitive or electro-sensitive protective devices (such as a safety edge) (**)
8. Check the impact forces again: if they fall within the limits (**) skip to point 10, otherwise
9. Allow the drive to move only in "Deadman" mode
10. Make sure all devices designed to detect obstacles within the system's operating range are working properly

(*) Before running the autose function, make sure you have performed all assembly and make-safe operations correctly, as set out in the installation warnings in the drive's manual.

(**) Based on the risk analysis, you may find it necessary to apply sensitive protective devices anyway

7.7) STATISTICS MENU

Used to view the version of the board, the total number of operations (in hundreds), the number of transmitters memorized and the last 30 errors (the first 2 digits indicate the position, the last 2 give the error code). Error 01 is the most recent.

7.8) PASSWORD MENU

Used to set a password for the board's wireless programming via the U-link network. With "PROTECTION LEVEL" logic set to 1,2,3,4, the password is required to access the programming menus. After 10 consecutive failed attempts to log in, you will need to wait 3 minutes before trying again. During this time, whenever an attempt is made to log in, the display will read "BLOC". The default password is 1234.

8) U-LINK OPTIONAL MODULES

Refer to the U-link instructions for the modules.

The use of some models causes lowered radio capacity. Adjust the system using an appropriate antenna tuned to 433MHz.

9) OPPOSITE SLIDING LEAVES (FIG. F)

Refer to the U-link instructions for the modules.

NOTE: On the board set as the Slave, the Safety Edge input (Safety Edge/Test Safety Edge/ 8k2 Safety Edge) should only be set to SAFE2.

10) RESTORING FACTORY SETTINGS (Fig.H)

WARNING: this operation will restore the control unit's factory settings and all transmitters stored in its memory will be deleted.

WARNING! Incorrect settings can result in damage to property and injury to people and animals.

- Cut off power to the board (Fig.H ref.1)
- Open the Stop input and press the - and OK keys together (Fig.H ref.2)
- Switch on the board's power (Fig.H ref.3)
- The display will read RST; confirm within 3 sec. by pressing the OK key (Fig.H ref.4)
- Wait for the procedure to finish (Fig.H ref.5)
- Procedure finished (Fig.H ref.6)

TABLE "A" - PARAMETERS MENU - (PRr Rr)

Parameter	min.	max.	Default	Personal	Definition	Description
oPEn worHt	5	300	300		Opening operation time [s]	Maximum motor operation time, during opening. Set the operation time so that it's slightly longer than the complete operating cycle time. The value is changed by the Autose cycle, adapting it to the operation time detected
cLS worHt	5	300	300		Closing operation time [s]	Maximum motor operation time, during closing. Set the operation time so that it's slightly longer than the complete operating cycle time. The value is changed by the Autose cycle, adapting it to the operation time detected
t c R	0	180	40		Automatic closing time [s]	Waiting time before automatic closing.
t r F L G h t c L r t	1	180	40		Time-to-clear traffic light zone [s]	Time-to-clear for the zone run through by traffic controlled by the traffic light.
o P d i S t S l o u d	0	99	0 (LEO B CBB 3 120 F02) 30 (Other models)		Slow-down distance during opening [%]	Slow-down distance for motor(s) during opening, given as a percentage of total travel. The Autose cycle changes the slow-down distance values if they don't allow at least 50cm of travel at slowed speed. WARNING: Once the parameter has been edited, a complete uninterrupted opening-closing cycle is required. WARNING: when the display reads "SET", obstacle detection is not active.
c L d i S t S l o u d	0	99	0 (LEO B CBB 3 120 F02) 30 (Other models)		Slow-down distance during closing [%]	Slow-down distance for motor(s) during closing, given as a percentage of total travel. The Autose cycle changes the slow-down distance values if they don't allow at least 50cm of travel at slowed speed. WARNING: Once the parameter has been edited, a complete uninterrupted opening-closing cycle is required. WARNING: when the display reads "SET", obstacle detection is not active.
PRr t i R L oPEn i n U	10	50	20		Partial opening [%]	Partial opening distance as a percentage of total opening following activation of PED pedestrian command.
o P F o r c E	1	99	41 (LEO B CBB 3 230 L02) 75 (Other models)		Leaf force during opening [%]	Force exerted by leaf/leaves during opening. Only for LEO B CBB 3 230 L02: This is the percentage of force delivered, beyond the force stored during the autose cycle (and subsequently updated), before an obstacle alarm is generated. The parameter is set automatically by the autose function. WARNING: It affects impact force directly: make sure that current safety requirements are met with the set value (*). Install anti-crush safety devices where necessary (**).

(*) In the European Union, apply standard EN 12453 for force limitations, and standard EN 12445 for measuring method.

(**) Impact forces can be reduced by using deformable edges.

INSTALLATION MANUAL

Parameter	min.	max.	Default	Personal	Definition	Description
<i>cLSForce</i>	1	99	41 (LEO B CBB 3 230 L02) 75 (Other models)		Leaf force during closing [%]	Force exerted by leaf/leaves during closing. Only for LEO B CBB 3 230 L02: This is the percentage of force delivered, beyond the force stored during the autosec cycle (and subsequently updated), before an obstacle alarm is generated. The parameter is set automatically by the autosec function. WARNING: It affects impact force directly: make sure that current safety requirements are met with the set value (*). Install anti-crush safety devices where necessary (**).
<i>oPSLsd.Force</i>	1	99	75		Leaf/leaves force during opening during slow-down	"Force exerted by leaf/leaves during opening at slow-down speed." Only for LEO B CBB 3 230 L02: This is the percentage of force delivered, beyond the force stored during the autosec cycle (and subsequently updated), before an obstacle alarm is generated. The parameter is set automatically by the autosec function. WARNING: It affects impact force directly: make sure that current safety requirements are met with the set value (*). Install anti-crush safety devices where necessary (**).
<i>cLSLsd.Force</i>	1	99	75		Leaf/leaves force during closing during slow-down [%]	"Force exerted by leaf/leaves during closing at slow-down speed." Only for LEO B CBB 3 230 L02: This is the percentage of force delivered, beyond the force stored during the autosec cycle (and subsequently updated), before an obstacle alarm is generated. The parameter is set automatically by the autosec function. WARNING: It affects impact force directly: make sure that current safety requirements are met with the set value (*). Install anti-crush safety devices where necessary (**).
<i>brAKE</i>	1	99	0		Braking [%]	Percentage of braking applied to stop motion of motor(s).
<i>PA IntEnRncE</i>	0	250	0		Programming number of operations for maintenance threshold [in hundreds]	Allows you to set a number of operations after which the need for maintenance will be reported on the AUX output configured as Maintenance or Flashing Light and Maintenance .



(*) In the European Union, apply standard EN 12453 for force limitations, and standard EN 12445 for measuring method.

(**) Impact forces can be reduced by using deformable edges.

TABLE "B" - LOGICS (LoU ic)

Logic	Definition	Default	Cross out setting used	Optional extras																									
<i>tCR</i>	Automatic Closing Time	0	0	Logic not enabled																									
			1	Switches automatic closing on																									
<i>FRSt cLS</i>	Fast closing	0	0	Logic not enabled																									
			1	Closes 3 seconds after the photocells are cleared before waiting for the set TCA to elapse.																									
<i>StEP-by-StEP POUEnE</i>	Step-by-step movement	0	0	Inputs configured as Start E, Start I, Ped operate with 4-step logic.																									
			1	Inputs configured as Start E, Start I, Ped operate with 3-step logic. Pulse during closing reverses movement.																									
			2	Inputs configured as Start E, Start I, Ped operate with 2-step logic. Movement reverses with each pulse.																									
				<table border="1"> <thead> <tr> <th colspan="4">step-by-step mov.</th> </tr> <tr> <th></th> <th>2 STEP</th> <th>3 STEP</th> <th>4 STEP</th> </tr> </thead> <tbody> <tr> <td>CLOSED</td> <td rowspan="2">OPENS</td> <td rowspan="2">OPENS</td> <td>OPENS</td> </tr> <tr> <td>DURING CLOSING</td> <td>STOPS</td> </tr> <tr> <td>OPEN</td> <td rowspan="2">CLOSES</td> <td>CLOSES</td> <td>CLOSES</td> </tr> <tr> <td>DURING OPENING</td> <td>STOP + TCA</td> <td>STOP + TCA</td> </tr> <tr> <td>AFTER STOP</td> <td>OPENS</td> <td>OPENS</td> <td>OPENS</td> </tr> </tbody> </table>	step-by-step mov.					2 STEP	3 STEP	4 STEP	CLOSED	OPENS	OPENS	OPENS	DURING CLOSING	STOPS	OPEN	CLOSES	CLOSES	CLOSES	DURING OPENING	STOP + TCA	STOP + TCA	AFTER STOP	OPENS	OPENS	OPENS
step-by-step mov.																													
	2 STEP	3 STEP	4 STEP																										
CLOSED	OPENS	OPENS	OPENS																										
DURING CLOSING			STOPS																										
OPEN	CLOSES	CLOSES	CLOSES																										
DURING OPENING		STOP + TCA	STOP + TCA																										
AFTER STOP	OPENS	OPENS	OPENS																										
<i>EncodEr</i>	Encoder	2	0	Operation with encoder disabled WARNING This setting fully disables the anti-crush safety device, with serious safety risks. Install active safety edges on closing and opening or switch to deadman operation. (see Deadman logic)																									
			1	Operation with encoder used as position sensor for acquiring slow-down distances. - Gate detection locked out. Manual setting of "opening force", "closing force", "opening slow-down force" and "closing slow-down force" parameters.																									
			2	Only active on LEO B CBB 3 230 L02 Automatic mode with encoder: slow-down and obstacle detection performed by means of encoder. Option of using "autosec" function. Adjustment of obstacle detection sensitivity (opening force, closing force, opening slow-down force, closing slow-down force parameters) (default setting).																									
				WARNING: Check that the force of impact measured at the points provided for by standard EN 12445 is lower than the value laid down by standard EN 12453. WARNING: Setting sensitivity incorrectly can result in damage to property and injury to people and animals.																									
<i>PrE-ALARn</i>	Pre-alarm	0	0	The flashing light comes on at the same time as the motor(s) start.																									
			1	The flashing light comes on approx. 3 seconds before the motor(s) start.																									

INSTALLATION MANUAL

Logic	Definition	Default	Cross out setting used	Optional extras
hold-to-run	Deadman	0	0	Pulse operation.
			1	Deadman mode. Input 61 is configured as OPEN UP. Input 62 is configured as CLOSE UP. Operation continues as long as the OPEN UP or CLOSE UP keys are held down.  WARNING: safety devices are not enabled.
			2	Emergency Deadman mode. Usually pulse operation. If the board fails the safety device tests (photozell or safety edge, Er0x) 3 times in a row, Deadman mode is enabled which will stay active for 1 minute after the OPEN UP - CLOSE UP keys are released. Input 61 is configured as OPEN UP. Input 62 is configured as CLOSE UP.  WARNING: with the device set to Emergency Deadman mode, safety devices are not enabled.
ibl oPEn	Block pulses during opening	0	0	Pulse from inputs configured as Start E, Start I, Ped has effect during opening.
			1	Pulse from inputs configured as Start E, Start I, Ped has no effect during opening.
ibl tCA	Block pulses during TCA	0	0	Pulse from inputs configured as Start E, Start I, Ped has effect during TCA pause.
			1	Pulse from inputs configured as Start E, Start I, Ped has no effect during TCA pause.
ibl cLoSE	Block pulses during closing	0	0	Pulse from inputs configured as Start E, Start I, Ped has effect during closing.
			1	Pulse from inputs configured as Start E, Start I, Ped has no effect during closing.
oPEn in othEr dIrEct.	Open in other direction	0	0	Standard operating mode (Fig.G Rif. 1).
			1	Opens in other direction to standard operating mode (Fig. G Rif.2)
SAFE 1	Configuration of safety input SAFE 1. 72	0	0	Input configured as Phot (photozell).
			1	Input configured as Phot test (tested photozell).
			2	Input configured as Phot op (photozell active during opening only).
SAFE 2	Configuration of safety input SAFE 2. 74	6	3	Input configured as Phot op test (tested photozell active during opening only).
			4	Input configured as Phot cl (photozell active during closing only).
			5	Input configured as Phot cl test (tested photozell active during closing only).
SAFE 3	Configuration of safety input SAFE 3. 77	2	6	Input configured as Bar, safety edge.
			7	Input configured as Bar, tested safety edge.
			8	Input configured as Bar 8k2 (Inactive on SAFE 3).
			9*	Input configured as Bar OP, safety edge with inversion active only while opening. If while closing, the movement stops.
			10*	Input configured as Bar OP TEST, safety edge tested with inversion active only while opening. If while closing, the movement stops.
			11*	Input configured as Bar OP 8k2, safety edge with inversion active only while opening. If while closing, the movement stops. (Inactive on SAFE 3).
			12*	Input configured as Bar CL, safety edge with inversion active only while closing. If while opening, the movement stops.
			13*	Input configured as Bar CL TEST, safety edge tested with inversion active only while closing. If while opening, the movement stops.
ic 1	Configuration of command input IC 1. 61	0	0	Input configured as Start E.
			1	Input configured as Start I.
ic 2	Configuration of command input IC 2. 62	4	2	Input configured as Open.
			3	Input configured as Close.
ic 3	Configuration of command input IC 3. 64	2	4	Input configured as Ped.
			5	Input configured as Timer.
ic 4	Configuration of command input IC 4. 65	3	6	Input configured as Timer Pedestrian.

INSTALLATION MANUAL

Logic	Definition	Default	Cross out setting used	Optional extras
AUX 3 (Setup for LEO B CBB 3 120 F02)	Configuration of AUX 3 output. 26-37	0	0	Output configured as 2nd Radio Channel.
			1	Output configured as SCA (gate open light).
			2	Output configured as Courtesy Light command.
			3	Output configured as Zone Light command.
			4	Output configured as Stair Light
			5	Output configured as Alarm
			6	Output configured as Flashing light
			7	Output configured as Latch
			8	Output configured as Magnetic lock
			9	Output configured as Maintenance
			10	Output configured as Flashing Light and Maintenance.
			11*	Not used
Fixed code	Fixed code	0	0	Receiver is configured for operation in rolling-code mode. Fixed-Code Clones are not accepted.
			1	Receiver is configured for operation in fixed-code mode. Fixed-Code Clones are accepted.
Protection Level	Setting the protection level	0	0	A - The password is not required to access the programming menus B - Enables wireless memorizing of transmitters. Operations in this mode are carried out near the control panel and do not require access: - Press in sequence the hidden key and normal key (T1-T2-T3-T4) of a transmitter that has already been memorized in standard mode via the radio menu. - Press within 10 sec. the hidden key and normal key (T1-T2-T3-T4) of a transmitter to be memorized. The receiver exits programming mode after 10 sec.; you can use this time to enter other new transmitters by repeating the previous step. C - Enables wireless automatic addition of clones. Enables clones generated with the universal programmer and programmed Replays to be added to the receiver's memory. D - Enables wireless automatic addition of replays. Enables programmed Replays to be added to the receiver's memory. E - The board's parameters can be edited via the U-link network
			1	A - You are prompted to enter the password to access the programming menus The default password is 1234. No change in behaviour of functions B - C - D - E from 0 logic setting
			2	A - You are prompted to enter the password to access the programming menus The default password is 1234. B - Wireless memorizing of transmitters is disabled. C - Wireless automatic addition of clones is disabled. No change in behaviour of functions D - E from 0 logic setting
			3	A - You are prompted to enter the password to access the programming menus The default password is 1234. B - Wireless memorizing of transmitters is disabled. D - Wireless automatic addition of Replays is disabled. No change in behaviour of functions C - E from 0 logic setting
			4	A - You are prompted to enter the password to access the programming menus The default password is 1234. B - Wireless memorizing of transmitters is disabled. C - Wireless automatic addition of clones is disabled. D - Wireless automatic addition of Replays is disabled. E - The option of editing the board's parameters via the U-link network is disabled. Transmitters are memorized only using the relevant Radio menu. IMPORTANT: This high level of security stops unwanted clones from gaining access and also stops radio interference, if any.
Serial mode	(Identifies how board is configured in a BFT network connection).	0	0	Standard SLAVE: board receives and communicates commands/diagnostics/etc.
			1	Standard MASTER: board sends activation commands (START, OPEN, CLOSE, PED, STOP) to other boards.
			2	SLAVE opposite leaves in local network : the control unit is the slave in an opposite leaves network with no smart module (fig.F)
			3	MASTER opposite leaves in local network: the control unit is the master in an opposite leaves network with no smart module (fig.F)
Address	Address	0	[____]	Identifies board address from 0 to 119 in a local BFT network connection. (see U-LINK OPTIONAL MODULES section)

INSTALLATION MANUAL

Logic	Definition	Default	Cross out setting used	Optional extras
<i>EHP11</i>	Configuration of EXPI1 input on input-output expansion board. 1-2	1	0	Input configured as Start E command.
			1	Input configured as Start I command.
			2	Input configured as Open command.
			3	Input configured as Close command.
			4	Input configured as Ped command.
			5	Input configured as Timer command.
			6	Input configured as Timer Pedestrian command.
			7	Input configured as Phot (photozell) safety.
			8	Input configured as Phot op safety (photozell active during opening only).
			9	Input configured as Phot cl safety (photozell active during closing only).
			10	Input configured as Bar safety (safety edge).
			11*	Input configured as safety Bar OP, safety edge with inversion active only while opening, if while closing the movement stops.
			12*	Input configured as safety Bar CL, safety edge with inversion active only while closing, if while opening the movement stops.
			13*	Input configured as Phot test safety, tested photozell. Input 3 (EXPI2) on input/output expansion board is switched automatically to safety device test input, EXPFAULT1.
			14*	Input configured as Phot op test safety, tested photozell active only while opening. Input 3 (EXPI2) on input/output expansion board is switched automatically to safety device test input, EXPFAULT1.
			15*	Input configured as Phot cl test safety, tested photozell active only while closing. Input 3 (EXPI2) on input/output expansion board is switched automatically to safety device test input, EXPFAULT1.
			16*	Input configured as Bar safety, tested safety edge. Input 3 (EXPI2) on input/output expansion board is switched automatically to safety device test input, EXPFAULT1.
			17*	Input configured as safety Bar OP test, safety edge with inversion active only while opening, if while closing the movement stops. Input 3 (EXPI2) on input/output expansion board is switched automatically to safety device test input, EXPFAULT1.
18*	Input configured as safety Bar CL test, safety edge with inversion active only while closing, if while opening the movement stops. Input 3 (EXPI2) on input/output expansion board is switched automatically to safety device test input, EXPFAULT1.			
<i>EHP12</i>	Configuration of EXPI2 input on input-output expansion board. 1-3	0	0	Input configured as Start E command.
			1	Input configured as Start I command.
			2	Input configured as Open command.
			3	Input configured as Close command.
			4	Input configured as Ped command.
			5	Input configured as Timer command.
			6	Input configured as Timer Pedestrian command.
			7	Input configured as Phot (photozell) safety.
			8	Input configured as Phot op safety (photozell active during opening only).
			9	Input configured as Phot cl safety (photozell active during closing only).
			10	Input configured as Bar safety (safety edge).
			11*	Input configured as safety Bar OP, safety edge with inversion active only while opening, if while closing the movement stops.
12*	Input configured as safety Bar CL, safety edge with inversion active only while closing, if while opening the movement stops.			
<i>EHPo1</i>	Configuration of EXPO2 output on input-output expansion board 4-5	11	0	Output configured as 2 nd Radio Channel.
			1	Output configured as SCA (gate open light).
			2	Output configured as Courtesy Light command.
			3	Output configured as Zone Light command.
			4	Output configured as Stair Light.
			5	Output configured as Alarm.
<i>EHPo2</i>	Configuration of EXPO2 output on input-output expansion board 6-7	11	6	Output configured as Flashing light.
			7	Output configured as Latch.
			8	Output configured as Magnetic lock.
			9	Output configured as Maintenance.
			10	Output configured as Flashing Light and Maintenance.
			11	Output configured as Traffic Light control with TLB board.
<i>trAFFic LIght PrEFLASHInG</i>	Traffic light pre-flashing	0	0	Pre-flashing switched off.
			1	Red lights flash, for 3 seconds, at start of operation.
<i>trAFFic LIght rEd LAMP ALWAYS on</i>	Steadily lit red light	0	0	Red lights off when gate closed.
			1	Red lights on when gate closed.

* Only active on FW \geq 1.05 - 2.05

INSTALLATION MANUAL

TABLE "C" – RADIO MENU (radio)

Logic	Description
<i>Add Start</i>	Add Start Key associates the desired key with the Start command
<i>Add 2ch</i>	Add 2ch Key associates the desired key with the 2nd radio channel command. Associates the desired key with the 2nd radio channel command. If no output is configured as 2nd Radio Channel Output, the 2nd radio channel controls the pedestrian opening.
<i>ErASE 64</i>	Erase List  WARNING! Erases all memorized transmitters from the receiver's memory.
<i>cod rH</i>	Read receiver code Displays receiver code required for cloning transmitters.
<i>wk</i>	ON = Enables remote programming of cards via a previously memorized W LINK transmitter. It remains enabled for 3 minutes from the time the W LINK transmitter is last pressed. OFF = W LINK programming disabled.

WARNING! Important safety instructions. Carefully read and comply with the Warnings and Instructions that come with the product as improper use can cause injury to people and animals and damage to property. Keep the instructions for future reference and hand them on to any new users.

This product is meant to be used only for the purpose for which it was explicitly installed. Any other use constitutes improper use and, consequently, is hazardous. The manufacturer cannot be held liable for any damage as a result of improper, incorrect or unreasonable use.

GENERAL SAFETY

Thank you for choosing this product. The Firm is confident that its performance will meet your operating needs.

This product meets recognized technical standards and complies with safety provisions when installed correctly by qualified, expert personnel (professional installer).

If installed and used correctly, the automated system will meet operating safety standards. Nonetheless, it is advisable to observe certain rules of behaviour so that accidental problems can be avoided:

- Keep adults, children and property out of range of the automated system, especially while it is moving.
- Do not allow children to play or stand within range of the automated system.
- The unit can be used by children over 8 years old and by people with reduced physical, sensory or mental capabilities or with no experience or necessary knowledge on condition they are supervised or trained about the safe use of the equipment and understand the risks involved. Children must not play with the unit. Cleaning and maintenance must not be performed by unsupervised children.
- Children must be supervised to ensure they do not play with the device. Do not allow children to play with the fixed controls. Keep remote controls out of reach of children.
- Do not work near hinges or moving mechanical parts.
- Do not hinder the leaf's movement and do not attempt to open the door manually unless the actuator has been released with the relevant release knob.
- Keep out of range of the motorized door or gate while they are moving.
- Keep remote controls or other control devices out of reach of children in order to avoid the automated system being operated inadvertently.

- The manual release's activation could result in uncontrolled door movements if there are mechanical faults or loss of balance.
- When using roller shutter openers: keep an eye on the roller shutter while it is moving and keep people away until it has closed completely. Exercise care when activating the release, if such a device is fitted, as an open shutter could drop quickly in the event of wear or breakage.
- The breakage or wear of any mechanical parts of the door (operated part), such as cables, springs, supports, hinges, guides. . . , may generate a hazard. Have the system checked by qualified, expert personnel (professional installer) at regular intervals according to the instructions issued by the installer or manufacturer of the door.
- When cleaning the outside, always cut off mains power.
- Keep the photocells' optics and illuminating indicator devices clean. Check that no branches or shrubs interfere with the safety devices.
- Do not use the automated system if it is in need of repair. In the event the automated system breaks down or malfunctions, cut off mains power to the system; do not attempt to repair or perform any other work to rectify the fault yourself and instead call in qualified, expert personnel (professional

installer) to perform the necessary repairs or maintenance. To allow access, activate the emergency release (where fitted).

- If any part of the automated system requires direct work of any kind that is not contemplated herein, employ the services of qualified, expert personnel (professional installer).
- At least once a year, have the automated system, and especially all safety devices, checked by qualified, expert personnel (professional installer) to make sure that it is undamaged and working properly.
- A record must be made of any installation, maintenance and repair work and the relevant documentation kept and made available to the user on request.
- Failure to comply with the above may result in hazardous situations.



SCRAPPING

Materials must be disposed of in accordance with the regulations in force. Do not throw away your discarded equipment or used batteries with household waste. You are responsible for taking all your waste electrical and electronic equipment to a suitable recycling centre.

Anything that is not explicitly provided for in the user guide is not allowed. The operator's proper operation can only be guaranteed if the instructions given herein are complied with. The Firm shall not be answerable for damage caused by failure to comply with the instructions featured herein.

While we will not alter the product's essential features, the Firm reserves the right, at any time, to make those changes deemed opportune to improve the product from a technical, design or commercial point of view, and will not be required to update this publication accordingly.

