

# BIG METRO

CE

Swing gate opener



**EN - Instructions and warnings for installation and use**

**IT - Istruzioni ed avvertenze per l'installazione e l'uso**

**FR - Instructions et avertissements pour l'installation et l'utilisation**

**ES - Instrucciones y advertencias para la instalación y el uso**

**DE - Installierungs-und Gebrauchsanleitungen und Hinweise**

**PL - Instrukcje i ostrzeżenia do instalacji i użytkowania**

**NL - Aanwijzingen en aanbevelingen voor installatie en gebruik**

**Nice**

**1 GENERAL SAFETY WARNINGS AND PRECAUTIONS**

**Recommendations regarding safety**

- **ATTENTION!** – This manual contains important instructions and recommendations regarding the safety of persons. Incorrect installation can cause serious injury. Read the manual completely before starting work. If in doubt, suspend the installation and request clarifications from the Nice After-sales Assistance.
- **ATTENTION!** – Important instructions: keep this manual for any future maintenance interventions and product disposal.
- **ATTENTION!** – In compliance with the most recent European Legislation, the realisation of an automatic door or gate must respect the Standards envisioned by the 2006/42/CE Directive (ex 98/37/CE) (Machinery Directive) and in particular, the EN 12445; EN 12453; EN 12635 and EN 13241-1 Standards, which allow to declare conformity of the automation. **Considering this**, all product installation, connection, inspection and maintenance operations must only be performed by a qualified and skilled technician!

**Recommendations for installation**

- Before starting installation, check whether this product is suitable to automate your gate or door (see chapter 3 and the "Product technical features"). If it is not suitable, DO NOT proceed with installation.
- **All installation and maintenance operations must take place with the automation disconnected from the electric power input.** If the power input disconnection device is not visible from the place where the automation is positioned, before starting work, affix a sign onto the disconnection device that states "ATTENTION! MAINTENANCE IN PROGRESS".
- Handle the automation with care during installation, preventing crushing, blows, falls or contact with liquids of any nature. Do not place the product near to heat sources or expose it to naked flames. All of these actions can damage it and be cause of malfunctioning or dangerous situations. If this occurs, suspend installation immediately and contact the Nice After-sales Assistance.
- Do not modify any product parts. Unauthorised operations can only cause malfunctioning. The manufacturer declines liability for damage deriving from arbitrary modifications to the product.
- If the gate or door to be automated has a pedestrian door the plant must be set up with a control system that prevents functioning of the motor when the pedestrian door is open.
- The product packaging material must be disposed of in compliance with local legislation.

**2 DESCRIPTION OF THE PRODUCT AND DESTINATION OF USE**

This product is destined to be used to automate gates or doors with hinged panels.

**ATTENTION!** – Any use different to that described and in environmental conditions different to those stated in this manual must be considered improper and prohibited!

The product is an electro-mechanical gear motor, with a 24 Vdc motor. The gear motor is powered by the external control unit, to which it must be connected.

If the electric energy is interrupted (*black-out*), the gate panels can be moved by releasing the gear motor using the relevant wrench; to perform the manual manoeuvre, see chapter 8.

The product is available in the version

- BM5024 with encoder, suitable for MC824H control units.

**Do not use gear motors with incompatible control units.**

**3.1 - Preliminary checks on installation**

Before performing installation, check the integrity of the product components, the adequacy of the model chosen and the suitability of the environment destined for installation.

**IMPORTANT** – The gear motor cannot automate a manual gate that does not have an efficient and safe mechanical structure. Moreover, it cannot solve defects caused by incorrect installation or bad maintenance of the gate itself.

**3.2 - Suitability of the gate to automate and the surrounding environment**

- Check that the gate mechanical structure is suitable to be automated and complies with the Standards in force on the territory (*if necessary, refer to the data given on the gate label*).
- Moving the gate panel manually in *Opening* and in *Closure*, check that the movement takes place with the same and constant friction in all points of the run (*there must not be moments of greater effort*).
- Check that the gate panel stays in equilibrium, i.e. that it does not move if taken manually into any position and left.
- Check that the space around the gear motor allows to manually release the gate panels easily and safely.
- Envision end run retainers on the ground both for opening and closure of the gate.
- Check that the gear motor fixing area is compatible with the clearance of the latter (**fig. 1**).

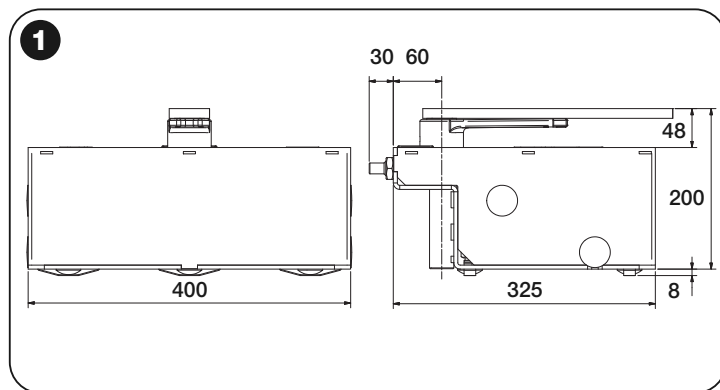

**3.3 - Limits of use for the product**

Before installing the product, check that the gate panel has dimensions and weight that lie within the limits given in **graph 1**; also evaluate the climatic conditions (e.g. strong wind) present in the place of installation. They can greatly reduce the values given in the graph.

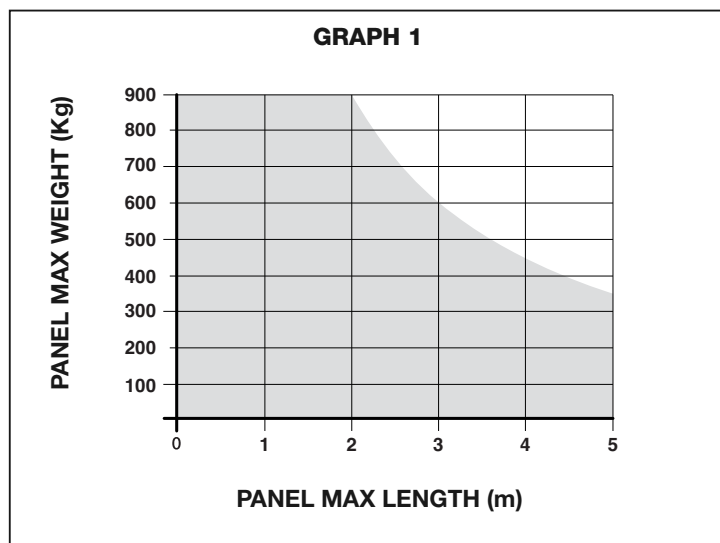

**3.4 - Set-up for installation**

**Fig. 2** shows an example of automated plant realised with Nice components. These components are positioned according to the typical and usual layout. With reference to **fig. 2**, establish the approximate position where each component envisioned in the plant will be installed and the most appropriate connection layout.

2

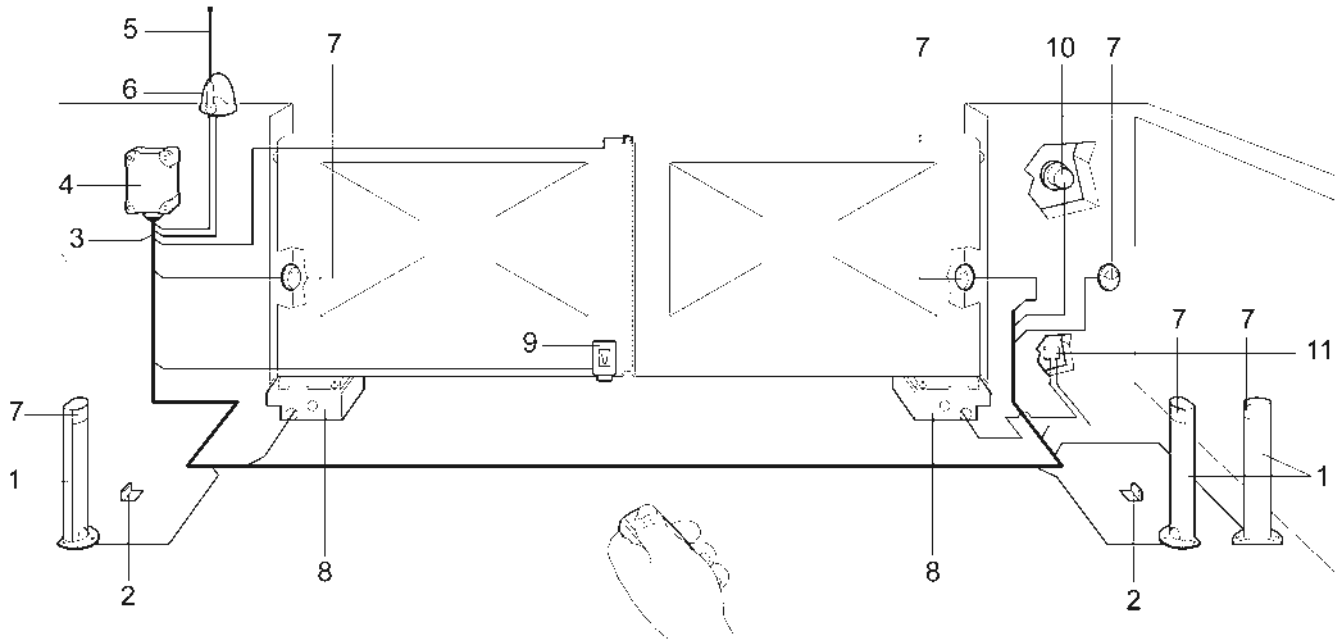

- 1 Photocell post
- 2 Pair of opening stops
- 3 230V line
- 4 Control panel (electrical panel)
- 5 Aerial
- 6 Flashing light
- 7 Photocell
- 8 Box with BIG METRO actuator
- 9 Vertical electric lock
- 10 Key-operated selector switch or digital keypad
- 11 Connector block (not supplied)

**3.5 - Mounting: Overall Dimensions and Positioning of Foundation Box**

- 1 Dig a generously sized foundation pit to house the foundation box (fig. 3); prepare a drain pipeline for draining off water and avoid the build-up of water.
- 2 If the gate is equipped with its own mechanical stops (fig. 2) skip directly to point 3. Otherwise secure the opening limiter accessory to the box (see paragraph 4).
- 3 Place the box inside the foundation hole; the stud must be aligned with the axis of the hinge (fig. 3).

- 4 Provide a duct for the electrical cables and a drainage pipe.
- 5 Bury the foundation box in concrete, making sure it is set level.
- 6 Mount the control bracket on the box's stud along with the ball (fig. 4).
- 7 Set the gate leaf on the release lever and weld them securely.
- 8 Grease using a suitable grease nozzle.

3

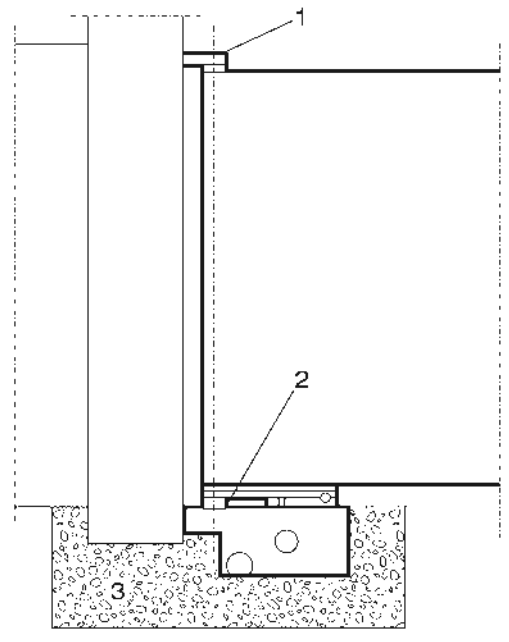

1- Hinge                      2- Pin                      3- Concrete

4

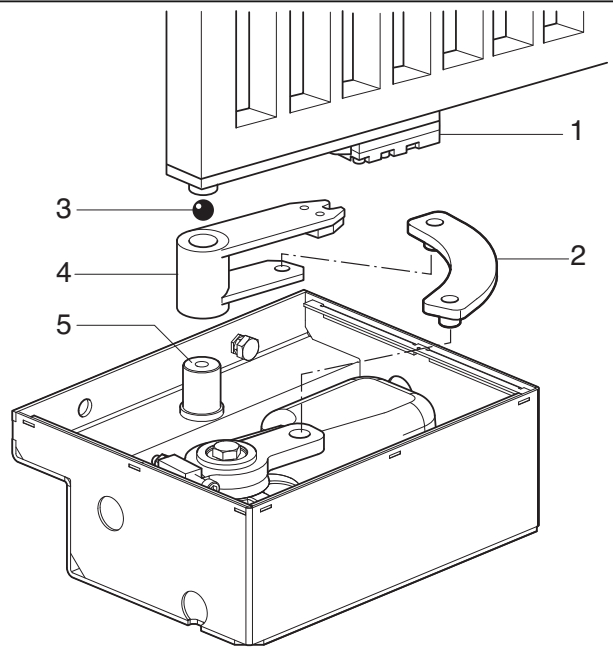

Release lever                      4 Control bracket  
 2 Connecting lever              5 Pin  
 3 Ball

### 3.6 - Installation of BIG METRO Gearmotor

- 1 Remove the nuts and washers shown in the figure on the right (fig. 5).
- 2 Place the gearmotor inside the foundation box making sure it faces the correct direction.
- 3 Secure the gearmotor with the previously removed washers and nuts.
- 4 Connect the gearmotor to the gate by means of the connecting lever (2) (fig. 4).

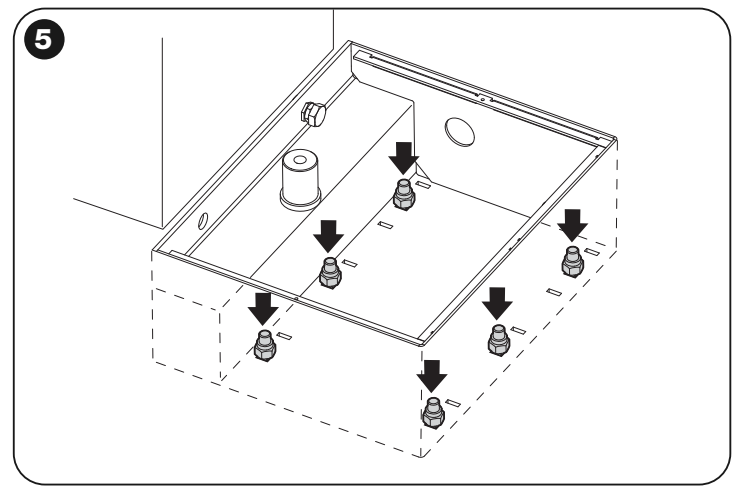

## 4 POSITION OF LIMIT SWITCHES

**Closing limit switch** (supplied with the motor) mount as shown in the figure

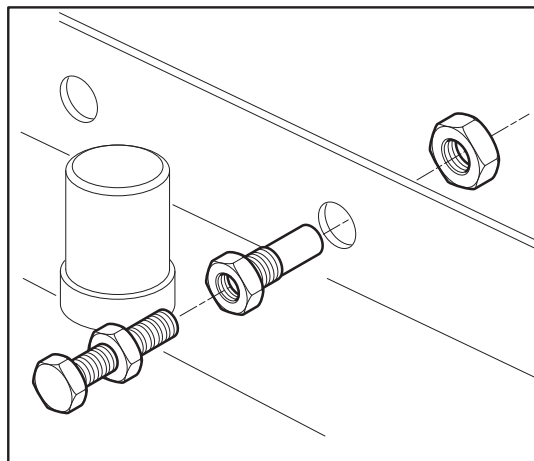
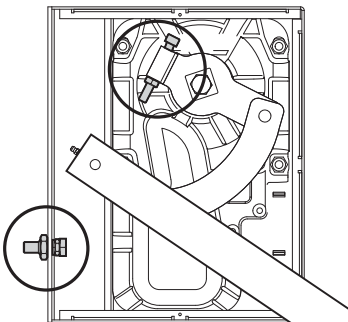
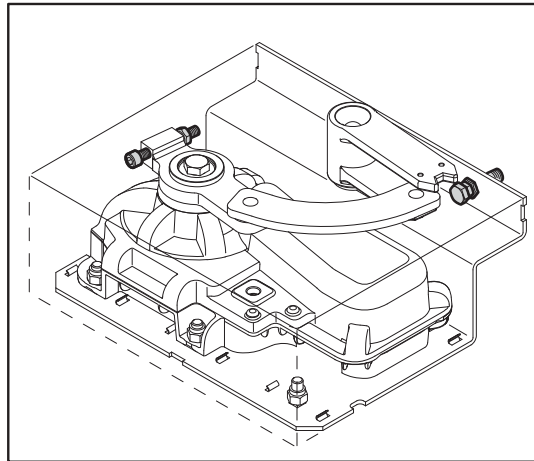

**Opening limit switch** (supplied with the motor) mount as shown in the figure

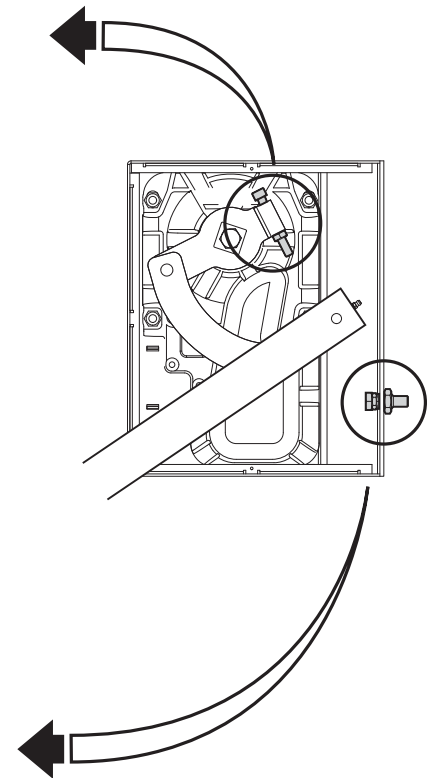

## 5 ELECTRIC CONNECTIONS

### Recommendations:

- The gear motor is supplied with an electric power input cable measuring 2 m. Therefore, if a greater distance must be covered to perform the electric connections, a diversion box must be used (not supplied). **IMPORTANT! – It is prohibited to join the electric cable inside the foundation case.**
- Make the electric connections with the mains power input disconnected.

To connect the power input cable to the control unit, see the manual regarding the latter and the following indications:

<b>Blu wire</b>	= 24 V motor power input
<b>Brown wire</b>	= 24 V motor power input
<b>Black wire</b>	= Encoder
<b>Grey wire</b>	= Encoder
<b>Yellow/Green wire</b>	= Earth

## 6 INSPECTION AND COMMISSIONING

Testing of the entire system must be conducted by experienced and qualified personnel, who must establish what tests are necessary depending on the risks involved. To test BIG METRO proceed as follows:

- close the gate;
- disconnect the power supply to the control unit;
- release the gearmotor from the gate leaf as shown in paragraph “Manual release device (Key and Lever-Operated Release)” in Chapter “Instructions and Warnings for Users of the BIG METRO Gearmotor”;
- open the gate manually all the way;
- make sure the gate opens and closes smoothly without any points of friction;
- make sure that the gate, when stopped in any position and released, does not display a tendency to start moving again;
- make sure that the safety systems and mechanical stops are in good working order;
- make sure that the screw connections are properly tightened;
- clean the inside of the box and make sure that the drain operates properly;
- when all the checks have been completed, re-connect the gearmotor and power the control unit;
- BIG METRO is not equipped with any torque adjustment device, therefore this operation is performed by the control unit;
- measure the impact force as provided by the EN12453 and EN12445 standards.

## 7 PRODUCT MAINTENANCE

BIG METRO does not require any special maintenance; however, routine checks conducted every six months at least will ensure the long life of the gearmotor as well as the correct and safe operation of the system.

**Maintenance consists simply in repeating the testing procedure.**

### DISPOSAL OF THE PRODUCT

**This product is an integral part of the automation system, and should therefore be disposed of together with it.**



As for the installation operations, even at the end of this product's life span, the dismantling operations must be carried out by qualified experts.

This product is made up of various types of materials: some can be recycled while others need to be disposed of. Find out about the recycling or disposal systems envisaged by your local regulations for this product category.

**Important!** – Parts of the product could contain pollutants or hazardous substances which, if released into the environment, could cause harmful effects to the environment itself as well as to human health.

As indicated by the symbol opposite, throwing away this product as domestic

waste is strictly forbidden. So dispose of it as differentiated waste, in accordance with your local regulations, or return the product to the retailer when you purchase a new equivalent product.

**Important!** – the local applicable regulations may envisage heavy sanctions in the event of illegal disposal of this product.

## 8 ACCESSORIES ON REQUEST

### PLA10 Vertical electric lock 12 Vac

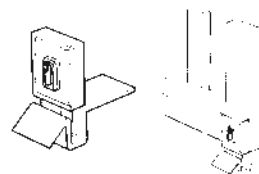

### PLA11 Horizontal electric lock 12 Vac

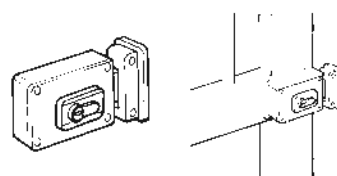

### BMA1 360° opening device

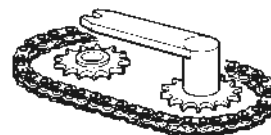

### MEA2 Key-operated release mechanism

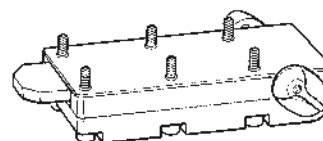

### MEA2 Key-operated release mechanism

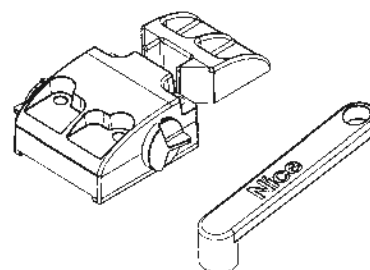

## 9 MANUALLY RELEASING THE GEARMOTOR

Perform the manual operation in the event of a power failure or system malfunction.

### MEA2 Type KEY-Operated Release (fig. 6)

- A Pull down the lock cover as shown in the figure.
  - B Insert the key and rotate it 90° clockwise.
  - C Move the gate manually (fig. 8).
- ⚠ The system will revert to automatic operation upon the first electrical manoeuvre.

### MEA3 Type Lever-Operated Release (fig. 7)

- A Pull down the lock cover as shown in the figure.
  - B Insert the key and rotate it 90° clockwise.
  - C Move the gate manually (fig. 8).
- ⚠ The system will revert to automatic operation upon the first electrical manoeuvre.

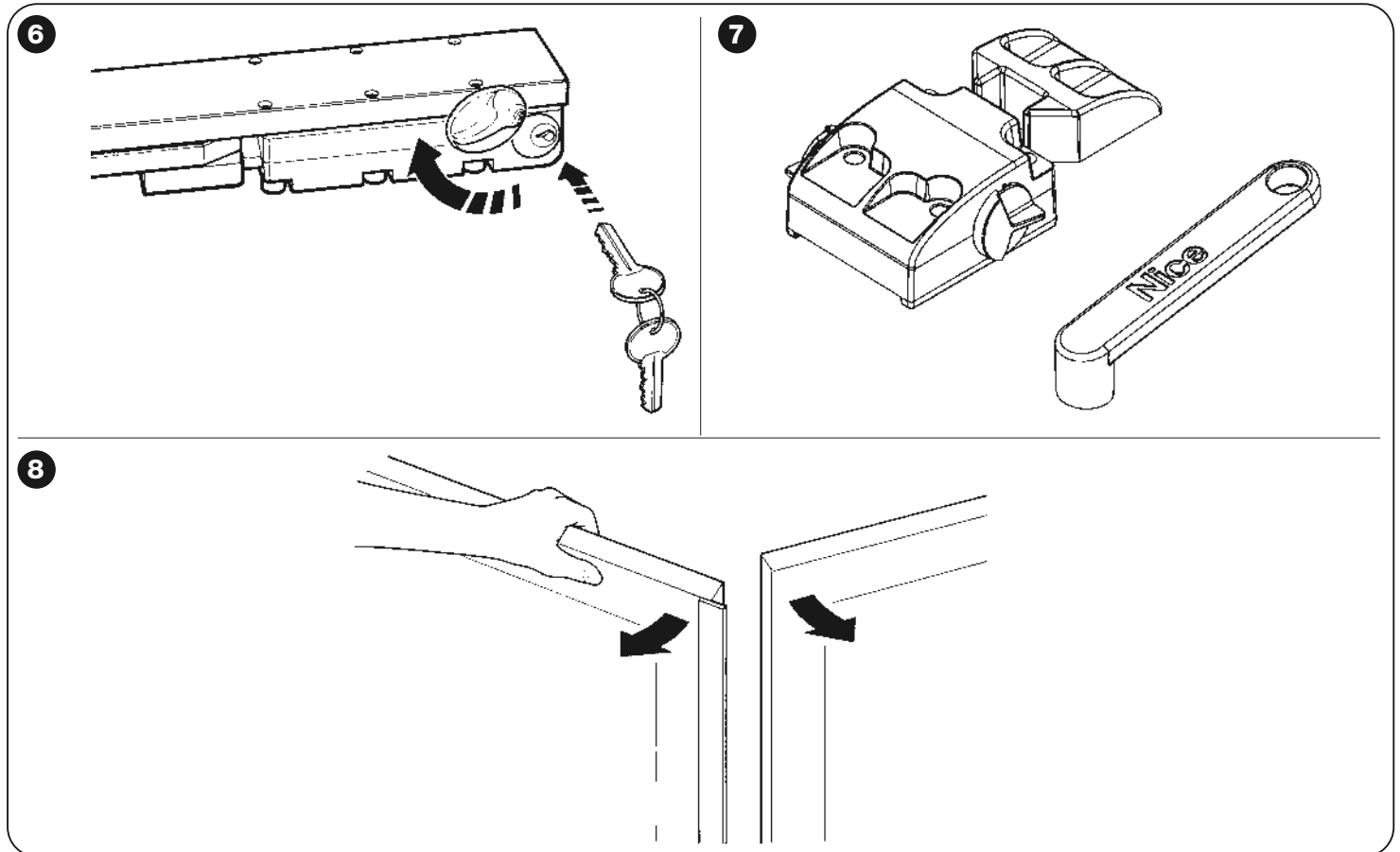

## PRODUCT TECHNICAL FEATURES

**RECOMMENDATIONS:** • All technical features stated make reference at a room temperature of 20°C (± 5°C). • Nice S.p.a. reserves the right to modify the product at any time it deems necessary, however maintaining the same functionality and destination of use.

■ Type	Electro-mechanical gear motors for gates and doors with hinged panels
■ Power input	24 V $\overline{\text{---}}$
■ Peak absorption	7 A
■ Maximum absorption	2 A
■ Potenza di picco	170 W
■ Maximum power	50 W
■ Protection rating	IP 67
■ Run	from 0° to 110° or 360°
■ Idle speed	0,8 rpm
■ Speed at nominal torque	0,65 rpm
■ Maximum torque	400 Nm
■ Nominal torque	100 Nm
■ Functioning temperature	from -20 °C to +50 °C
■ Cycles/hour at the nominal torque	45
■ Duration	Estimated between about 100.000 e 250,000 manoeuvre cycles, according to the conditions given in Table 1
■ Dimensions	230 mm x 206 mm x h 88 mm
■ Weight	15 Kg (gear motor with foundation space)

## Product duration

The duration and average economic life of the product. The value of duration is strongly affected by the fatigue index of the manoeuvres performed by the automation: i.e. the sum of all factors that contribute to wear of the product (see Table 1).

To establish the probable duration of your automation, proceed as follows:

01. Calculate the fatigue index by adding the percentage values of the items present in **Table 1**;
02. In **Graph 2** of the value just found, trace a vertical line that crosses the curve; from this point trace a horizontal line until the "manoeuvre cycles" line is crossed. The value determined is the estimated duration of your product.

The estimation of duration is made on the basis of the design calculations and the test results performed on prototypes. In fact, as it is an estimate, it does not represent any guarantee regarding the effective duration of the product.

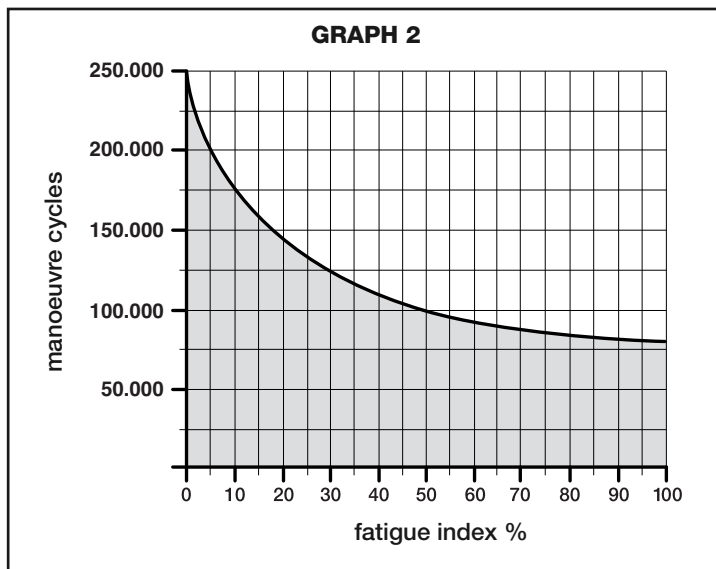

Length of the panel	≤ 2 m	2 - 3 m	3 - 4 m	4 - 5 m	
Weight of the panel	<b>Fatigue index</b>				
	< 150 Kg	0 %	10 %	20 %	30 %
	150 - 350 Kg	10 %	20 %	30 %	40 %
	350 - 550 Kg	20 %	30 %	40 %	50 %
	550 - 750 Kg	30 %	40 %	50 %	-
750 - 900 Kg	40 %	50 %	-	-	
<b>Environmental temperature exceeding 40°C or below 0°C or humidity exceeding 80%</b>				15 %	
<b>Blind panel</b>				20 %	
<b>Installation in windy area</b>				15 %	

**Example of the duration calculation of an Big Metro gear motor (refer to Table 1 and Graph 2):**

- panel length: 3 m and panel weight: 500 Kg = fatigue index: 30%
  - Installation in windy areas = fatigue index: 15%
  - does not have other elements of fatigue
- Total fatigue index = 45%
- Estimated duration = 110.000 manoeuvre cycles

## CE DECLARATION OF CONFORMITY and declaration of incorporation of "quasi machinery"

Declaration in accordance with the Directives: 2004/108/EC (EMC); 2006/42/EC (MD) appendix II, part B

*Note - The contents of this declaration correspond to declarations in the official document deposited at the registered offices of Nice S.p.a. and in particular to the last revision available before printing this manual. The text herein has been re-edited for editorial purposes.  
A copy of the original declaration can be requested from Nice S.p.a. (TV) I*

<b>Number:</b> 389/BM..	<b>Revision:</b> 0	<b>Language:</b> EN
<b>Manufacturer's Name:</b>	NICE s.p.a.	
<b>Address:</b>	Via Pezza Alta 13, Z.I. Rustignè, 31046 Oderzo (TV) Italy	
<b>Person authorised to draw up technical documentation:</b>	Mr. Oscar Marchetto	
<b>Type:</b>	"Big Metro" electromechanical gearmotor	
<b>Models:</b>	BM5024	
<b>Accessories:</b>		

The undersigned, Luigi Paro, in the role of Managing Director, declares under his sole responsibility, that the product specified above conforms to the provisions of the following directives:

- DIRECTIVE 2004/108/EC OF THE EUROPEAN PARLIAMENT AND COUNCIL of 15 December 2004 regarding the approximation of member state legislation related to electromagnetic compatibility, repealing directive 89/336/EEC, according to the following harmonized standards: EN 61000-6-2:2005, EN 61000-6-3:2007
- Directive 2006/42/EC THE EUROPEAN PARLIAMENT AND COUNCIL of 17 May 2006 regarding machinery and which amends directive 95/16/EC (recasting)
- It is hereby declared that the pertinent technical documentation has been compiled in compliance with appendix VII B of directive 2006/42/EC and that the following essential requirements have been observed: 1.1- 1.1.2- 1.1.3- 1.2.1-1.2.6- 1.5.1-1.5.2- 1.5.5- 1.5.6- 1.5.7- 1.5.8- 1.5.10- 1.5.11
- The manufacturer undertakes to transmit to the national authorities, in response to a motivated request, all information regarding the "quasi-machine", while maintaining full rights to the related intellectual property.
- Should the "quasi machine" be put into service in a European country with an official language other than that used in this declaration, the importer is obliged to arrange for the relative translation to accompany this declaration.
- The "quasi-machine" must not be used until the final machine in which it is incorporated is in turn declared as compliant, if applicable, with the provisions of directive 2006/42/EC.

The product also complies with the following standards:  
EN 60335-1:2002 + A1:2004 + A11:2004 + A12:2006 + A2:2006 + A13:2008, EN 60335-2-103:2003

The product also complies, within the constraints of applicable parts, with the following standards:  
EN 13241-1:2003, EN 12445:2002, EN 12453:2002, EN 12978:2003

Oderzo, 1 April 2011

Luigi Paro (Managing Director)



**Nice SpA**  
Oderzo TV Italia  
info@niceforyou.com

[www.niceforyou.com](http://www.niceforyou.com)



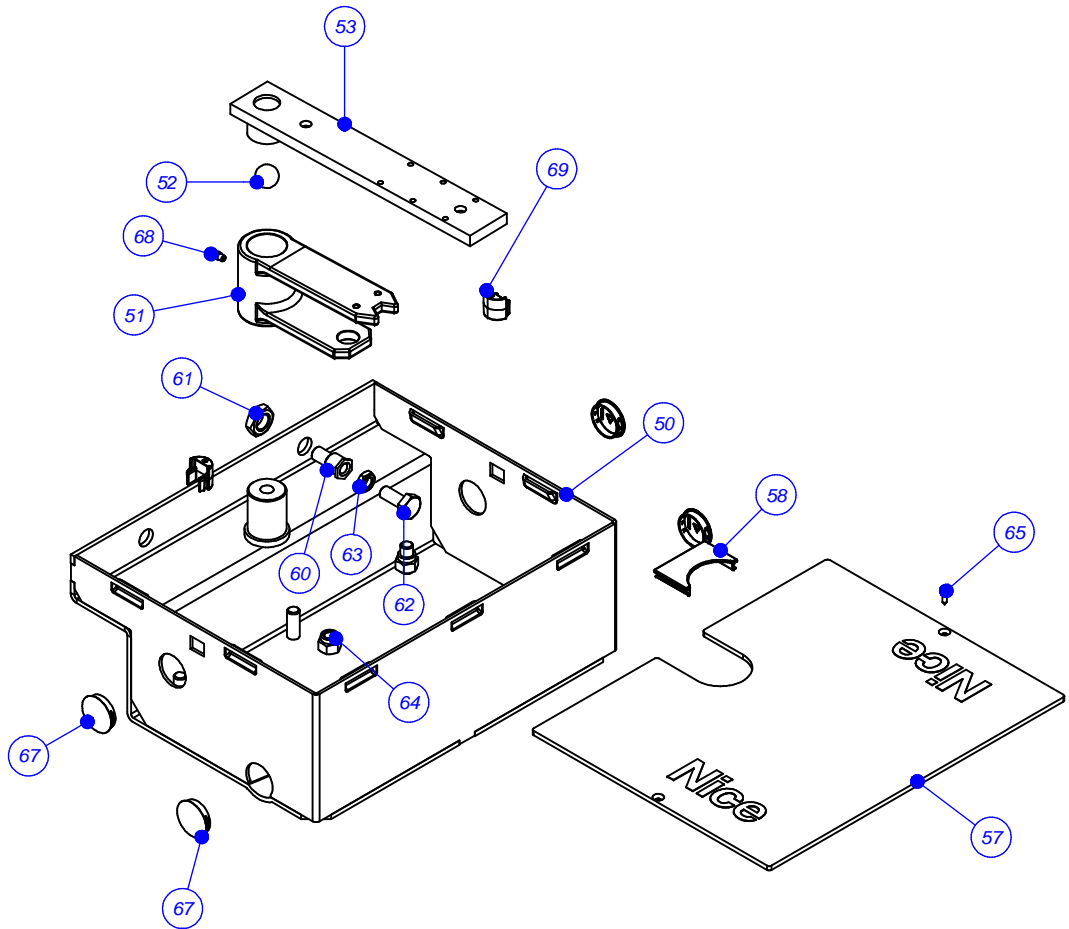

# Moon

CE

## Control unit MC824H

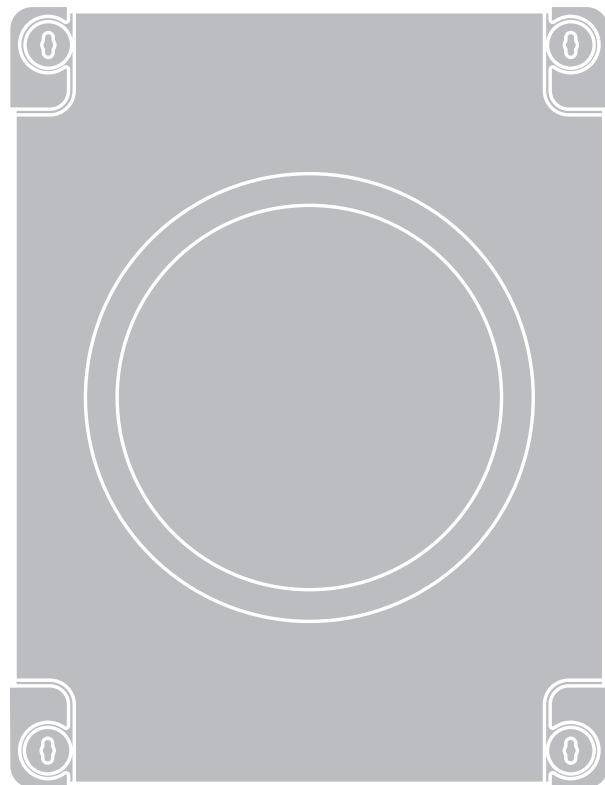

**EN - Instructions and warnings for installation and use**

**IT - Istruzioni ed avvertenze per l'installazione e l'uso**

**FR - Instructions et avertissements pour l'installation et l'utilisation**

**ES - Instrucciones y advertencias para la instalación y el uso**

**DE - Installierungs-und Gebrauchsanleitungen und Hinweise**

**PL - Instrukcje i ostrzeżenia do instalacji i użytkowania**

**NL - Aanwijzingen en aanbevelingen voor installatie en gebruik**

**Nice**

# Contents

<b>GENERAL SAFETY WARNINGS AND PRECAUTIONS</b> . . . . .	1
Safety warnings . . . . .	1
Installation warnings . . . . .	1
Safety warnings . . . . .	1
<b>1 - PRODUCT DESCRIPTION AND INTENDED USE</b> . . . . .	1
<b>2 - INSTALLATION</b> . . . . .	1
2.1 - Preliminary checks for installation . . . . .	1
2.2 - Product application limits . . . . .	2
2.3 - Typical system . . . . .	2
2.4 - Installation of control unit . . . . .	2
<b>3 - ELECTRICAL CONNECTIONS</b> . . . . .	2
3.1 - Description of electrical connections . . . . .	2
3.2 - Electrical connections of MC824H control unit . . . . .	2
3.3 - Connection of other devices to MC824H . . . . .	3
3.4 - Connected device address assignment to MC824H . . . . .	3
3.5 - Initial start-up and electrical connections . . . . .	3
3.6 - Learning of the devices connected to MC824H . . . . .	3
3.7 - Selecting the type of gearmotor connected to MC824H and learning the mechanical stop positions . . . . .	3
3.7.1 - Learning in automatic mode . . . . .	4
3.7.2 - Learning in manual mode . . . . .	4
3.7.3 - Learning in combined mode . . . . .	4
3.8 - Checking movement of gate leafs . . . . .	4
<b>4 - TESTING AND COMMISSIONING</b> . . . . .	4
4.1 - Testing . . . . .	4
4.2 - Commissioning . . . . .	5
<b>5 - PROGRAMMING</b> . . . . .	5
5.1 - Level one programming (ON-OFF functions) . . . . .	5
5.2 - Level two programming (adjustable parameters) . . . . .	6
5.3 - Special functions . . . . .	7
5.4 - Deletion of memory . . . . .	7
<b>6 - WHAT TO DO IF... (troubleshooting guide)</b> . . . . .	8
<b>7 - FURTHER DETAILS</b> . . . . .	9
7.1 - Connecting a radio receiver . . . . .	9
7.2 - Connecting Oview programming unit . . . . .	9
7.3 - Connecting the Solemyo solar energy system . . . . .	9
7.4 - Connecting model PS324 buffer battery . . . . .	9
<b>8 - PRODUCT MAINTENANCE</b> . . . . .	10
<b>PRODUCT DISPOSAL</b> . . . . .	10
<b>TECHNICAL CHARACTERISTICS OF THE PRODUCT</b> . . . . .	10
<b>CE DECLARATION OF CONFORMITY</b> . . . . .	1
<b>Instructions and warnings for the user</b> . . . . .	V
<b>Images</b> . . . . .	XII

## Safety warnings

- **IMPORTANT! – This manual contains important instructions and warnings for personal safety.** Incorrect installation could cause serious physical injury. Read all parts of the manual carefully before starting work. If in doubt, interrupt installation and contact the Nice Service Centre for clarifications.
- **IMPORTANT! – Important instructions: keep this manual in a safe place to enable future product maintenance and disposal procedures.**
- **IMPORTANT! – Under the latest European legislation, automatic door and gate installations must be compliant with the standards specified in Directive 2006/42/EC (formerly 98/37/EC) (the Machinery Directive) and the standards EN 12445, EN 12453, EN 12635 and EN 13241-1 in particular, which enable conformity of the automated functionality to be declared. In the light of the above, all work involving installation, connection, testing and maintenance of the product must be carried out exclusively by qualified and competent technicians!**

## Installation warnings

- Before commencing installation, check that the product is suitable for the intended kind of use (see paragraph 2.2 “Limits of use” and “Product technical specifications”). If not suitable, do NOT proceed with installation.
- The contents of this manual refer to a standard system as described in **fig. 2a**.
- **All installation and maintenance work must be carried out with the automation system disconnected from the electricity supply.** If the power disconnection device cannot be seen from where the automation system is positioned, then before starting work a notice must be attached to the disconnection device bearing the words “CAUTION! MAINTENANCE IN PROGRESS”.
- On the power line to the system, install a device for disconnection from the power mains with a gap between contacts that assures complete disconnection in the conditions of overvoltage category III.
- Connect the control unit to an electric power line equipped with an earthing system.
- During installation, handle the product with care, avoiding the risk of crushing, impact, dropping or contact with any type of liquid. Never place the product near sources of heat or expose to naked flames. This may damage product components and cause malfunctions, fire or hazardous situations. If this occurs, suspend installation immediately and contact the Nice Service Centre.
- Never make modifications to any part of the product. Operations other than as specified can only cause malfunctions. The manufacturer declines all liability for damage caused by makeshift modifications to the product.
- The product’s packaging materials must be disposed of in full compliance with local regulations.

## Safety warnings

- The product should not be used by children or people with impaired physical, sensorial or mental capacities or who have not received adequate training in the safe use of the product.
- In the vicinity of the automation children must be supervised to ensure that they do not play with it.
- Do not allow children to play with the fixed control devices. Keep remote control devices out of the reach of children.

## 1 PRODUCT DESCRIPTION AND INTENDED USE

MC824H is an electronic control unit for the automation of swing gates. **IMPORTANT! – Any other use than as specified herein or in environmental conditions other than as stated in this manual is to be considered improper and is strictly prohibited!**

The control unit is ready for connection to devices belonging to the Opera system, the Bluebus system and the Solemyo solar energy supply system. If powered from the mains, it can house a buffer battery (model PS324, optional accessory), which ensures that the automation can perform a number of manoeuvres for several hours in the event of a power failure. Other available accessories include the dedicated receivers with “SM” fitting (SMX, OXI, etc.).

## 2 INSTALLATION

### 2.1 - Preliminary checks for installation

Before proceeding with installation, check the condition of the product components, suitability of the selected model and conditions of the intended installation environment:

- Ensure that all material used is in perfect condition and suitable for use.
- Ensure that all conditions of use remain within the limits of product application (paragraph 2.2) and within the limit values stated in the “Product technical specifications”.
- Ensure that the selected installation environment is compatible with the overall dimensions of the product (**fig. 1**).
- Ensure that the selected surfaces for product installation are solid and guarantee a stable fixture.

- Make sure that the fixing zone is not subject to flooding. If necessary, mount the product raised from the ground.
- Ensure that the space around the product enables easy and safe access.
- Make sure that all the electrical cables used are of the type listed in **Table 1**.
- Make sure that the automation is provided with mechanical stops on both closing and opening.

## 2.2 - Product application limits

The product may be used exclusively with gearmotors METRO (model ME3024), MOBY (model MB4024-MB5024), HYPPO (model HY7024-HY7124), TOONA (model TO4024-TO5024-TO7024), X-metro (model XME2124), Big-Metro (BM5024), Metroelite, Wingoelite and in accordance with the corresponding usage limits.

## 2.3 - Typical system

**Fig. 2a** shows an example of an automation system set up with **Nice** components:

- a - Control unit
- b - Gearmotor
- c - Flashing light
- d - Photocell
- e - Digital keyboard - Transponder reader - Key selector
- f - Photocell post
- g - Opening mechanical stops

- h - Closure mechanical stops
- i - Electric lock

These parts are positioned according to a typical standard layout. With reference to **fig. 2a**, locate the approximate position for installation of each component making up the system. **Important** – Before installation, prepare the electrical cables needed for your system, referring to **fig. 2b** and “**Table 1 - Technical characteristics of electrical cables**”.

**Important** – During installation of ducting for electrical cables and the introduction of cables into the control unit enclosure, be aware that due to possible water deposits in the junction boxes, the connecting ducts may form condensation inside the control unit which is liable to damage the electronic circuits.

## 2.4 - Installation of control unit

To mount the control unit, proceed as shown in **fig. 3**:

01. Open the control unit box by undoing the relevant screws (**fig. 3-A**);
02. Prepare the electrical cable routing holes (**fig. 3-B**);
03. Mount the box (**fig. 3-C**);
04. The electrical connections can now be made: see chapter 3.

**Important!** – To prepare the inlets for the electrical cable ducting, holes must be drilled in the lower side of the control unit box. **Note** – *If necessary, the lateral cable inlet may be used, but only with the aid of suitable duct fittings.* To install the other devices present in the automation, refer to the relevant instruction manuals.

**TABLE 1 - Technical specifications of electrical cables (fig. 2b)**

Connection	Cable type	Maximum admissible length
<b>A:</b> CONTROL UNIT POWER cable	1 cable 3 x 1,5 mm <sup>2</sup>	30 m ( <b>note 1</b> )
<b>B:</b> FLASHING LIGHT with aerial cable	1 cable 2 x 0,5 mm <sup>2</sup> 1 shielded cable type RG58	20 m 20 m (less than 5 m recommended)
<b>C:</b> BLUEBUS DEVICES cable	1 cable 2 x 0,5 mm <sup>2</sup>	20 m ( <b>note 2</b> )
<b>D:</b> KEY-OPERATED SELECTOR SWITCH cable	2 cables 2 x 0,5 mm <sup>2</sup> ( <b>note 3</b> )	50 m
<b>E:</b> GEARMOTOR POWER cable	1 cable 3 x 1,5 mm <sup>2</sup> ( <b>note 4</b> )	10 m
<b>F:</b> ENCODER CONNECTION cable	1 cable 2 x 1 mm <sup>2</sup> ( <b>note 4</b> )	10 m
<b>G:</b> ELECTRIC LOCK CONNECTION	1 cable 2 x 1 mm <sup>2</sup>	10 m

**Note 1** – If the power cable is longer than 30 m, a cable with a larger cross-section is required (3 x 2.5 mm<sup>2</sup>) and safety earthing is necessary in the vicinity of the automation.

**Note 2** – If the Bluebus cable is longer than 20 m (up to max. 40 m), a cable with a larger cross-section is required (2 x 1 mm<sup>2</sup>).

**Note 3** – These 2 cables can be replaced by a single 4 x 0.5 mm<sup>2</sup> cable.

**Note 4** – These 2 cables can be replaced by a single 5 x 1.5 mm<sup>2</sup> cable.

**IMPORTANT!** – The cables used must be suited to the installation environment.

## 3 ELECTRICAL CONNECTIONS

The electrical connection of the various devices (photocells, digital keyboard, transponder card readers, etc.) contained in the automation with the control unit must be made by means of the Nice “Bluebus” system.

### 3.1 - Description of electrical connections (fig. 6)

<b>AERIAL</b>	input for the radio receiver aerial
<b>FLASH</b>	output for 1 flashing light with 12V (maximum 21W) bulb. [*]
<b>ELS</b>	output for 12Vac (maximum 15VA) electric lock. [*]
<b>S.C.A.</b>	“Open Gate Light”: output for 1 indication lamp (24V maximum 4W). [*]
<b>BLUEBUS</b>	input for compatible devices (MOFB, MOFOB, MOB and MOTB); they are connected in parallel using two conductors through which both the electricity supply and the communication signals travel; no polarity needs to be observed. The electrical connection to be used is of the parallel type and no polarity needs to be observed. During the learning stage, the control unit will recognise individually all devices connected to it thanks to a unique code. Each time a device is added or eliminated, it will be necessary to make the control unit perform the learning operation (see paragraph 3.6).
<b>STOP</b>	input for devices that cause the immediate interruption of the manoeuvre in progress (with a short reverse run); NO and NC contacts, as well as devices with 8.2 kΩ constant resistance output (sensitive edges) can be connected to this input. Each device connected to this input is recognised individually by the control unit during the learning stage (paragraph 3.6); in this stage, if the control unit detects any variations with respect to the learned state, it causes a STOP. One or more devices of the same or different kinds can be connected to this input: <ul style="list-style-type: none"> <li>– connect a number of NO devices in parallel without quantity limits;</li> <li>– several NC devices can be connected in series, with no limits as to quantity;</li> <li>– connect 2 devices with 8.2 kΩ constant resistance output in parallel. If there are more than 2 devices, they must be connected in a cascade with just one 8.2 kΩ termination resistance;</li> <li>– connect 2 NO and NC devices in parallel, placing a 8.2 kΩ</li> </ul>

resistance in series on the NC contact (this also allows for a combination of three devices NO - NC and 8.2 kΩ)

<b>P.P.</b>	input for devices which control Step-by-Step manoeuvres. NO contacts can be connected to this input
<b>OPEN</b>	input for devices which control only opening manoeuvre. NO contacts can be connected to this input
<b>CLOSE</b>	input for devices which control only closure manoeuvre. NO contacts can be connected to this input
<b>ENC1</b>	input encoder – gearmotor 1 (terminal 1, 2); it is not necessary to observe any polarity
<b>ENC2</b>	input encoder – gearmotor 2 (terminal 4, 5); it is not necessary to observe any polarity
<b>M1</b>	output for gearmotor 1 (terminal 7, 8, 9)
<b>M2</b>	output for gearmotor 2 (terminal 10, 11, 12)

[\*] The FLASH, ELS and S.C.A. outputs can be programmed with other functions (see “TABLE 5 - 1st level functions”; or via Oview programmer, see chapter 7.2).

### 3.2 - Electrical connections of MC824H control unit

After mounting the control unit box and preparing the electrical cable holes (chapter 2.4 and fig. 3), make the electrical connections:

#### **IMPORTANT!**

**– All electrical connections must be made with the unit disconnected from the mains power supply and with the buffer battery disconnected, if present in the automation.**

**– Connections must be made exclusively by qualified personnel.**

– The electrical power line must be fitted with a device that enables complete disconnection of the automation from the mains. The disconnection device must have a gap between contacts that ensures complete disconnection in the conditions of overvoltage category III, in compliance with installation regulations. If necessary, this device guarantees rapid and safe disconnection from the mains, and therefore should be located in view of the automation. However, if located in a concealed position, it must have a system that blocks against inadvertent or unauthorised reconnection to prevent all risks. The disconnection device is not supplied with the product.

01. First connect the electric power cable (**fig. 4**) and secure by means of the cable clamp;
02. Then connect the electric cables of motors M1 and M2, observing the symbols on the label (**fig. 5**);

**a)** connect the motor that activates the lower leaf (the second to start the opening manoeuvre) to terminal M1 and then the respective encoder to terminals 1-2;

**b)** connect the motor that activates the upper leaf (the first to start the opening manoeuvre) to terminal M2 and then the respective encoder to terminals 4-5;

**IMPORTANT! – If there is only one gearmotor in the system, connect it to terminal M2 leaving terminal M1 free;**

**03.** Then connect the electric cables of the various devices present, with reference to **fig. 6** and paragraph 3.3 **Note** – *To facilitate cable connections, the terminals can be removed from their seats;*

**3.3 - Connection of other devices to MC824H**

If further devices present in the system need to be powered, for example a transponder card reader or the key selector light, these devices can be connected to the control unit using terminals “P.P. (positive)” and “STOP (negative)” (**fig. 6**). The power supply voltage is 24 Vdc, -30% ÷ +50%, with maximum available current 200 mA.

**Note** – The voltage present on terminals “P.P.” and “STOP” remains connected even when the “Stand By” function is activated on the card.

**3.4 - Connected device address assignment to MC824H**

To enable control unit recognition of the devices connected to the BlueBus system, they need to be routed. This operation must be performed by positioning the electric jumper correctly on each device; see the relative instruction manual of individual devices: see **fig. A** and **Table 2**.

At the end of the installation procedure or following the removal of photocells or other devices, the self-learning procedure for these devices must be performed. See paragraph 3.6.

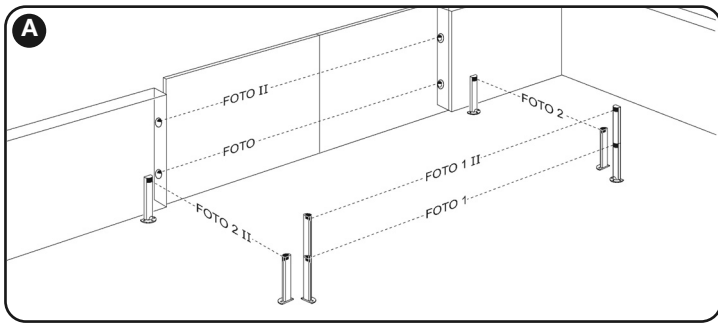

Photocell	Jumpers
<b>FOTO</b> External photocell h = 50 with trip on closure (stops and inverts movement)	
<b>FOTO II</b> External photocell h = 100 with trip on closure (stops and inverts movement)	
<b>FOTO 1</b> Internal photocell h = 50 with trip on closure (stops and inverts movement) and opening (stops and restarts when photocell is disengaged)	
<b>FOTO 1 II</b> Internal photocell h = 100 with trip on closure (stops and inverts movement) and opening (stops and restarts when photocell is disengaged)	
<b>FOTO 2</b> Internal photocell with trip on opening (stops and inverts movement)	
<b>FOTO 2 II</b> Internal photocell with trip on opening (stops and inverts movement)	
<b>FOTO 3</b> <b>CONFIGURATION NOT ADMITTED</b>	

**3.5 - Initial start-up and electrical connections**

After powering up the control unit, perform the following checks:

- After a few seconds, make sure that the “Bluebus” LED (**fig. 7**) flashes regularly with a frequency of about one flash per second.
- Make sure that the LEDs on the photocells (**fig. 7**) flash (both on TX and RX). The type of flashing is not important during this stage.
- Make sure that the flashing light connected to the FLASH output is off.

If the above conditions are not satisfied, switch off the power supply to the control unit and check the electrical connections previously made.

**3.6 - Learning of the devices connected to MC824H**

After the initial power-up, the control unit must be able to recognise the devices connected to the “Bluebus” and “Stop” inputs.

**IMPORTANT! – The learning procedure must be performed even if no device is connected to the control unit.**

The control unit is able to recognise the various connected devices individually through the self-learning procedure and detect possible faults. For this reason it is necessary to perform self-learning every time a new device is added or an existing device is removed.

To indicate when the self-learning procedure is required, LEDs **L1** and **L2** on the control unit (**fig. 7**) emit a number of slow flashes:

- 01.** Press and hold down ◀ and “Set” keys at the same time (**fig. 7**).
- 02.** Release the keys when LEDs L1 and L2 start flashing quickly (after approx. 3 seconds).
- 03.** Wait a few seconds for the control unit to complete the device learning phase.
- 04.** At the end of this phase, the “Stop” LED must be lit and LEDs “L1” and “L2” must be turned off (LEDs L3 and L4 may start flashing).

**3.7 - Selecting the type of gearmotor connected to MC824H and learning the mechanical stop positions**

After learning the devices (paragraph 3.6), the type of motors connected must be selected (see **Table 3**) and the positions of the mechanical stops must also be learnt (maximum opening and maximum closing). There are three ways to perform this procedure: **automatic**, **manual** and **combined**.

In **automatic mode**, the control unit learns the positions of the mechanical stops and calculates the most suitable offset value for the leafs (SA and SC, **fig. B**).

In **manual mode**, the eight positions of the mechanical stops (**fig. B**) are programmed one by one, moving the leafs to the required points. The position to program is identifiable by the flashing status of one of the eight leds (L1-L8), see **Table 4**.

In **combined mode**, the automatic procedure can be performed and then, using the manual procedure, one or more positions may be modified, with the exception of positions “0” and “1” (**fig. B**) which coincide with the positions of the

Led	Gearmotor type	Led	Gearmotor type
<b>L1</b>	MB4024 - MB5024 -	<b>L5</b>	TO7024
	HY7024 - HY7124	<b>L6</b>	BM5024
<b>L2</b>	ME3024	<b>L7</b>	METROELITE
<b>L3</b>	TO4024 - XME2124	<b>L8</b>	WINGOELITE
<b>L4</b>	TO5024		

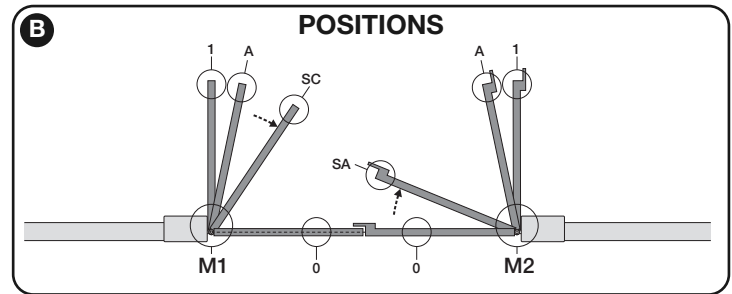

Position	Led	Description
<b>Position 0 (motor 1)</b>	<b>L1</b>	Maximum closing position: when leaf 1 reaches closing mechanical stop
<b>Position 0 (motor 2)</b>	<b>L2</b>	Maximum closing position: when leaf 2 reaches closing mechanical stop
<b>Position SA (motor 2)</b>	<b>L3</b>	Opening offset: when leaf 2 passes this position the opening of leaf 1 begins
<b>Position A (motor 1)</b>	<b>L4</b>	Required opening position: position in which the leaf connected to motor 1 must stop at the end of an opening manoeuvre. This position does not have to coincide with the opening mechanical stop, and can be selected as required from position “0” or “1”.
<b>Position A (motor 2)</b>	<b>L5</b>	Required opening position: position in which the leaf connected to motor 2 must stop at the end of an opening manoeuvre. This position does not have to coincide with the opening mechanical stop, and can be selected as required from position “0” or “1”.
<b>Position SC (motor 1)</b>	<b>L6</b>	Closing offset: when leaf 1 reaches this position, leaf 2 begins to close
<b>Position 1 (motor 1)</b>	<b>L7</b>	Maximum opening position: when leaf 1 reaches the opening mechanical stop
<b>Position 1 (motor 2)</b>	<b>L8</b>	Maximum opening position: when leaf 2 reaches the opening mechanical stop

mechanical stops.

**3.7.1 - Learning in automatic mode**

- 01.** Press and hold down “Set” and ▶ keys at the same time.
- 02.** Release the keys when LED **L1** begins to flash (motor selection: **not per-**

formed) or when any of the LEDs L1 ... L8 lights up (motor selection: **already performed**).

03. Press ◀ or ▶ keys within 10 seconds to go to the **LED** corresponding to the type of gearmotor connected to the control unit (see **Table 3**);
04. **Press and hold down** the “Set” key for at least 3 seconds to memorize the selected gearmotor. After 3 sec. LED **L1** starts flashing, then release the key;
05. **Press and hold** keys “Set” and “▶” at the same time.
06. Release the keys when leds “L3” and “L4” start flashing quickly (after approx. 3 seconds).
07. Ensure that the automation completes the following sequences of manoeuvres:
  - a - Low speed closure of gearmotor M1 through to the mechanical stop
  - b - Low speed closure of gearmotor M2 through to the mechanical stop
  - c - low speed opening of gearmotor M2 and gearmotor M1 through to the mechanical stop
  - d - High speed closure of gearmotors M1 and M2

#### Warnings:

- If the first manoeuvre (a) does not close the leaf controlled by motor M1 but closes the one controlled by M2, press key “◀” or “▶” to stop the learning phase. At this point, invert the connections of motors M1 and M2 on the terminals on the control unit and then those of the respective encoders; after this start the procedure from point 05;
  - If the first two manoeuvres (a e b) are not “closing” but are “opening”, press key “◀” or “▶” to stop the learning phase. At this point, on the gearmotor that completed the opening manoeuvre, invert the polarity of the two wires of gearmotor M1 (terminals 7 and 9 for M1; terminals 10 and 12 for M2) and then start the procedure from point 05;
08. At the end of the Closing manoeuvre of the 2 motors (d), leds “L3” and “L4” turn off to indicate that the procedure has been completed correctly.

#### Warnings:

- During the automatic learning procedure, if a photocell trips or a device connected to the “stop” input is activated, the procedure is interrupted and led L1 starts flashing. To resume the learning process, the procedure must be started again from point 05;
- The automatic learning procedure can be repeated at any time, also after installation; for example following modifications to the position of the mechanical stops.

### 3.7.2 - Learning in manual mode

#### Caution! – From step 05 onwards:

- to move from led L1 to L8, briefly press key ◀ or ▶ (the led flashes to indicate the current position);
- to move the motor in one or the other direction, press and hold key ◀ or ▶.

01. **Press and hold down** “Set” and ▶ keys at the same time;
02. Release the keys when LED **L1** begins to flash (motor selection: **not performed**) or when any of the LEDs L1 ... L8 lights up (motor selection: **already performed**);
03. Press ◀ or ▶ keys within 10 seconds to go to the **LED** corresponding to the type of gearmotor connected to the control unit (see **Table 3**);
04. **Press and hold down** the “Set” key for at least 3 seconds to memorize the selected gearmotor. After 3 sec. LED **L1** starts flashing, then release the key;
05. **LED L1 flashes: position 0 of M1**

To bring motor 1 to **position 0 (fig. B)**: **press and hold down** the ◀ or ▶ keys. On reaching the position, release the key to stop the manoeuvre. To memorise the position, **press and hold down** the “Set” key for at least 3 seconds and then release it (after 2 seconds LED L1 remains on and on releasing the “Set” key LED L2 begins flashing).

#### • LED L2 flashes: position 0 of M2

To bring motor 2 to **position 0 (fig. B)**: press and hold down the ◀ or ▶ keys. On reaching the position, release the key to stop the manoeuvre. To memorise the position, press and hold down the “Set” key for at least 3 seconds and then release it (after 2 seconds LED L2 remains on and on releasing the “Set” key LED L3 begins flashing).

#### • LED L3 flashes: position SA of M2

To bring motor 2 to **position SA (fig. B)**: press and hold down the ◀ or ▶ keys. On reaching the position, release the key to stop the manoeuvre. To memorise the position, press and hold down the “Set” key for at least 3 seconds and then release it (after 2 seconds LED L3 remains on and on releasing the “Set” key LED L4 begins flashing).

#### • LED L4 flashes: position A of M1

To bring motor 1 to **position A (fig. B)**: press and hold down the ◀ or ▶ keys. On reaching the position, release the key to stop the manoeuvre. To memorise the position, press and hold down the “Set” key for at least 3 seconds and then release it (after 2 seconds LED L4 remains on and on releasing the “Set” key LED L5 begins flashing).

#### • LED L5 flashes: position A of M2

To bring motor 2 to **position A (fig. B)**: press and hold down the ◀ or ▶ keys. On reaching the position, release the key to stop the manoeuvre. To memorise the position, press and hold down the “Set” key for at least 3 seconds and then release it (after 2 seconds LED L5 remains on and on releasing the “Set” key LED L6 begins flashing).

#### • LED L6 flashes: position SC of M1

To bring motor 1 to **position SA (fig. B)**: press and hold down the ◀ or ▶ keys. On reaching the position, release the key to stop the manoeuvre. To memorise the position, press and hold down the “Set” key for at least 3 seconds and then release it (after 2 seconds LED L6 remains on and on releasing the “Set” key LED L7 begins flashing).

#### • LED L7 flashes: position 1 of M1

To bring motor 1 to **position 1 (fig. B)**: press and hold down the ◀ or ▶ keys. On reaching the position, release the key to stop the manoeuvre. To

memorise the position, press and hold down the “Set” key for at least 3 seconds and then release it (after 2 seconds LED L7 remains on and on releasing the “Set” key LED L8 begins flashing).

#### • LED L8 flashes: position 1 of M2

To bring motor 2 to **position 1 (fig. B)**: press and hold down the ◀ or ▶ keys. On reaching the position, release the key to stop the manoeuvre. To memorise the position, press and hold down the “Set” key for at least 3 seconds and then release it to exit programming (after 2 seconds LED L8 remains on until the “Set” key is released).

**Note – Manual programming in a system with a single gearmotor:** proceed as described at the beginning of this paragraph from step 01. **At step 05** proceed as follows:

- **Program the positions related to led L1 (0 of M1) and L7 (1 of M1) as follows:** press and hold the “Set” key for at least 3 seconds and then release (after 2 seconds the LED remains on, and on release of the “Set” key the next LED begins flashing).
- **Do not program the positions related to led L3 (SA of M2) - L4 (A of M1) - L6 (SC of M1):** briefly press key ◀ or ▶ to move between positions.

### 3.7.3 - Learning in combined mode

Perform this procedure after completing the automatic learning cycle:

01. **Press and hold** keys “Set” and “▶” at the same time.
02. Release the key when led **L1** starts to flash (selection of motors: **never performed**) or when any one of leds L1 to L8 lights up (selection of motors: **already performed**);
03. Within 10 seconds, press key “◀” or “▶” to move the **Led** corresponding to the type of gearmotor connected to the control unit (see **Table 3**);
04. **Press and hold** the key “Set” for at least 3 seconds, to memorise the selected gearmotor. After the 3-second interval, led “L1” starts flashing; at this point release the key;
05. Briefly press key “◀” or “▶” to move the flashing led (L1-L8) to the position to be programmed and proceed for each position, as described in step 05 of the manual learning procedure (paragraph 3.7.2).  
Repeat this operation for all other positions to be modified.

To complete the manual learning process, press key “▶” repeatedly to move the led that flashing beyond position L8.

### 3.8 - Checking movement of gate leaves

At the end of the learning procedure, it is advisable to make the control unit perform a few opening and closing manoeuvres to ensure that the gate moves correctly and to check for installation or setting defects.

01. Press “Open”. Verify correct offset of the leaves on opening and ensure that the opening manoeuvre comprises the acceleration phase, the constant speed phase and the deceleration phase. At the end of the manoeuvre, the leaves must stop a few centimetres from the opening mechanical stop.
02. Press the “Close” key and check that the closure manoeuvre includes the acceleration, constant speed and deceleration phases. Check that the leaf closure offset is correct. At the end of the manoeuvre, the leaves must be perfectly closed on the mechanical closure stop.
03. Make sure that the flashing light flashes at intervals of 0.5 sec on, 0.5 sec off during manoeuvres.

## 4 TESTING AND COMMISSIONING

These are the most important phases of automation set-up for ensuring maximum system safety. The test can also be performed as a periodic check of automation devices. Testing and commissioning of the automation must be performed by skilled and qualified personnel, who are responsible for the tests required to verify the solutions adopted according to the risks present, and for ensuring observance of all legal provisions, standards and regulations, and in particular all requirements of the standard EN 12445, which establishes the test methods for checking automations for doors and gates. The additional devices must undergo a specific test for functionality and correct interaction with MC824H. Refer to the instruction manuals of the individual devices.

### 4.1 - Testing

The sequence of operations to be performed for testing and described below refers to a typical system (**fig. 2**):

- 1 Ensure that everything stated in the “Installation warnings” chapter has been observed.
- 2 Release the gearmotors for manual operation as described in the relevant instruction manual. Pushing at the prescribed point for manual operation, check that it is possible to open and close the leaves with a force lower than 390 N.
- 3 Lock the gearmotors (see relevant instruction manual).
- 4 Using the control devices (transmitter, key-operated selector switch or control pushbuttons, etc.), perform tests of opening, closing and stopping the gate, and ensure that leaf movement corresponds to specifications. Test several times to check for leaf movement and any defects in assembly or adjustment and any possible points of friction.
- 5 Check operation of all system safety devices one at a time (photocells, sensitive edges, etc.). Each time a device is activated the “BLUEBUS” LED on the control unit must flash rapidly twice to confirm acknowledgement of the event.
- 6 If hazardous situations generated by the moving leaves are protected by means of impact force limitation, measure the force as specified in the stan-

standard EN 12445. If gearmotor force control is used as auxiliary function with the system for reduction of impact force, test and identify the setting that obtains the best results.

## 4.2 - Commissioning

**Commissioning can only be performed after positive results of all test phases.**

- 1 Prepare the automation technical documentation, which must contain the following documents: overall drawing of the automation, electrical wiring diagram, risk assessment and solutions adopted, manufacturer's declaration of conformity for all devices used and installer's declaration of conformity.
- 2 Apporre sul cancello una targhetta contenente almeno i seguenti dati: tipo di automazione, nome e indirizzo del costruttore (responsabile della "messa in servizio"), numero di matricola, anno di costruzione e marchio "CE".
- 3 Affix a dataplate on the door, specifying at least the following data: type of automation, name and address of manufacturer (responsible for commissioning), serial number, year of construction and CE mark.
- 4 Compile the "**Operation manual**" for the automation and forward it to the owner.
- 5 Compile the form "**Maintenance schedule**" containing all maintenance instructions for all devices in the automation and forward it to the owner.
- 6 Before commissioning the automation, ensure that the owner is adequately informed of all associated risks and hazards.

For all the above-mentioned documentation, Nice provides instruction manuals, guides and pre-filled forms through its technical support service. Also see: [www.nice-service.com](http://www.nice-service.com)

## 5 PROGRAMMING

The control unit has 3 keys **OPEN** (◀), **STOP (SET)**, **CLOSE** (▶) that can be used both for controlling the unit during testing and for programming the available functions.

The programmable functions available are divided into 2 levels and their relative operating status is displayed by means of the 8 LEDs (**L1...L8**) on the control unit (**LED lit** = function active; **LED off** = function not active).

**Use the programming keys:**

**OPEN** (◀): – key for controlling gate opening; – selection key during programming.

**STOP/SET:** key for stopping a manoeuvre; if pressed for more than 5 seconds, it enables entry to programming mode.

**CLOSE** (▶): – key for controlling gate closure; – selection key during programming.

### 5.1 - Level one programming (ON-OFF functions)





All level 1 functions are set by default to "**OFF**" and may be modified at any time. To check the functions see **Table 5**. For the programming procedure see **Table 6**.

**IMPORTANT** – In the programming procedure, the maximum time interval that can elapse between activation of one key and the next is 10 seconds. When this time elapses, the procedure terminates automatically, memorising the modifications made up until then.

**TABLE 5 - First level functions**

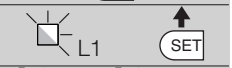
LED	Function	Description
L1	<b>Automatic closure</b>	<u>Function ACTIVE:</u> after an opening movement, there is a pause (equal to the programmed time) after which the control unit automatic initiates a closure movement. The factory setting for the Pause time is 30 sec. <u>Function NOT ACTIVE:</u> function is "semiautomatic" type.
L2	<b>Reclose after photo</b>	<u>Function ACTIVE:</u> if the photocells are activated during the opening or closing manoeuvre, the pause time is reduced to 5 seconds regardless of the programmed pause time. With "automatic closure" disabled, if the photocells are activated during closure the "automatic closure" is activated with the programmed "pause time".
L3	<b>Always close</b>	<u>Function ACTIVE:</u> in the event of a power failure, even of short duration, when power is restored the control unit detects gate open and automatically starts a closure manoeuvre, preceded by 5 seconds of pre-flashing. <u>Function NOT ACTIVE:</u> when power is restored the gate remains where it is.
L4	<b>Stand by (Bluebus)</b>	<u>Function ACTIVE:</u> 1 minute after the end of the manoeuvre, the control unit turns off the "Bluebus" output (connected devices) and all the LEDs apart from the Bluebus LED which will flash more slowly. When the control unit receives a command normal operation is restored (with a short delay). This function has the purpose of reducing consumption, an important aspect with battery or photovoltaic panel power supply.
L5	<b>Electric lock/Courtesy light</b>	<u>Function ACTIVE:</u> the "electric lock" output switches its operation to "courtesy light". <u>Function NOT ACTIVE:</u> the output operates as an electric lock.
L6	<b>Pre-flash</b>	<u>Function ACTIVE:</u> a 3 second pause can be added between the flashing light signal and the start of the manoeuvre to provide advance warning of a hazard situation. <u>Function NOT ACTIVE:</u> flashing light signal coincides with the start of the manoeuvre.
L7	<b>Close" becomes "Partial open 1"</b>	<u>Function ACTIVE:</u> the "Close" input of the control unit switches operation mode to "Partial Open 1"
L8	<b>"Gate open light" or "Maintenance light"</b>	<u>Function ACTIVE:</u> the "gate open light" output on the control unit switches to the "maintenance light" function. <u>Function NOT ACTIVE:</u> the output operates as "gate open light".

**TABLE 6 – Programming procedure (first level functions)**

<b>01.</b> Press and hold down the " <b>Set</b> " key for approx. 3 seconds;	
<b>02.</b> Release the key when LED " <b>L1</b> " starts flashing;	
<b>03.</b> Press the "◀" or "▶" key to move the flashing LED to the LED representing the function to be modified;	
<b>04.</b> Press " <b>Set</b> " to change the status of the function: (short flash = OFF; long flash = ON);	
<b>05.</b> Wait 10 seconds (maximum time) to exit the programming mode.	

**Note** – During this procedure, points 03 and 04 need to be repeated when programming other functions to "ON" or "OFF" during the phase itself.

## 5.2 - Level two programming (adjustable parameters)

All level 2 functions are set by default as highlighted in **grey** in **Table 7**, and may be modified at any time as explained in **Table 8**.

The parameters can be set on a scale from 1 to 8. To check the value corre-

sponding to each LED see **Table 8**. **IMPORTANT** – In the programming procedure, the maximum time interval that can elapse between activation of one key and the next is 10 seconds. When this time elapses, the procedure terminates automatically, memorising the modifications made up until then.

**TABLE 7 - Second level functions**







Input LED	Parameter	LED (level)	Value	Description
<b>L1</b>	<b>Pause time</b>	L1	5 seconds	Sets the pause time, namely the time which lapses before automatic closure. This will only take effect if closing is active.
		L2	15 seconds	
		L3	30 seconds	
		L4	45 seconds	
		L5	60 seconds	
		L6	80 seconds	
		L7	120 seconds	
		L8	180 seconds	
<b>L2</b>	<b>Step by step function</b>	L1	Open – stop – close – stop	Sets the sequence of commands associated with the “Step-by-Step”, “Open”, or “Close” inputs or the radio control.  <b>Note</b> – When setting <b>L4</b> , <b>L5</b> , <b>L7</b> and <b>L8</b> , the behaviour of the “Open” and “Close” commands is also modified.
		L2	Open – stop – close – open	
		L3	Open – close – open – close	
		L4	Apartment block: • In the opening manoeuvre the “Step by Step” and “Open” commands have no effect; the “Close” command causes the movement to be inverted, i.e. the closure of the leaf. • In the closure manoeuvre the “Step by Step” and “Open” commands cause the movement to be inverted, i.e. the leaf to open; the “Close” command has no effect.	
		L5	Apartment block 2: • In the opening manoeuvre the “Step by Step” and “Open” commands have no effect; the “Close” command causes the movement to be inverted, i.e. the closure of the leaf. <b>If the transmitted command persists for more than 2 seconds, a “Stop” is performed.</b> • In the closure manoeuvre the “Step by Step” and “Open” commands cause the movement to be inverted, i.e. the leaf to open; the “Close” command has no effect. <b>If the transmitted command persists for more than 2 seconds, a “Stop” is performed.</b>	
		L6	Step-by-step 2 (less than 2 sec. generates partial opening).	
		L7	Hold-to-run: the manoeuvre is performed only if the transmitted command persists; if the command is interrupted the manoeuvre stops.	
		L8	Opening in semi-automatic mode, closing in hold-to-run mode.	
<b>L3</b>	<b>Motor speed</b>	L1	Very slow	Sets the motor speed during normal travel.
		L2	Slow	
		L3	Medium	
		L4	Fast	
		L5	Very fast	
		L6	Extremely fast	
		L7	Fast opening, Slow Closing	
		L8	Extremely fast Opening, Medium Closing	
<b>L4</b>	<b>Motor discharge after closing</b>	L1	No discharge	Sets duration of “short inversion” of both motors after performing Close manoeuvre with the aim of reducing the final residual thrust.
		L2	Level 1 - Minimum discharge (about 100 ms)	
		L3	Level 2 - ...	
		L4	Level 3 - ...	
		L5	Level 4 - ...	
		L6	Level 5 - ...	
		L7	Level 6 - ...	
		L8	Level 7 - Maximum discharge (about 800 ms)	
<b>L5</b>	<b>Motor force</b>	L1	Level 1 - Minimum Force	Adjusts the force of both motors
		L2	Level 2 - ...	
		L3	Level 3 - ...	
		L4	Level 4 - ...	
		L5	Level 5 - ...	
		L6	Level 6 - ...	
		L7	Level 7 - ...	
		L8	Level 8 - Maximum Force	
<b>L6</b>	<b>Pedestrian or partial opening</b>	L1	Pedestrian 1 (opening of leaf M2 to 1/4 of total opening)	Sets type of opening associated with “Partial open 1” command.  In levels L5, L6, L7, L8; “minimum” opening means the smaller opening out of M1 and M2; for example, if M1 opens to 90° and M2 opens to 110°, the minimum opening is 90°
		L2	Pedestrian 1 (opening of leaf M2 to 1/2 of total opening)	
		L3	Pedestrian 3 (opening of leaf M2 to 3/4 of total opening)	
		L4	Pedestrian 4 (Complete opening of leaf 2)	
		L5	Partial 1 (opening of two leaves to 1/4 of “minimum” opening)	
		L6	Partial 2 (opening of two leaves to 1/2 of “minimum” opening)	
		L7	Partial 3 (opening of two leaves to 3/4 of “minimum” opening)	
		L8	Partial 4 (opening of two leaves to “minimum” opening)	

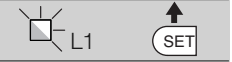

<b>L7</b>	<b>Maintenance warning</b>	L1	500	Controls the number of manoeuvres: when this number is exceeded, the control unit signals an automation maintenance request; see paragraph 5.3.2. – Maintenance warning.
		L2	1000	
		L3	1500	
		L4	2500	
		L5	5000	
		L6	10000	
		L7	15000	
		L8	20000	
<b>L8</b>	<b>List of faults</b>	L1	Manoeuvre 1 result (most recent)	The type of fault that has occurred in the last 8 manoeuvres can be established  See TABLE 12 – Fault log.
		L2	Manoeuvre 2 result	
		L3	Manoeuvre 3 result	
		L4	Manoeuvre 4 result	
		L5	Manoeuvre 5 result	
		L6	Manoeuvre 6 result	
		L7	Manoeuvre 7 result	
		L8	Manoeuvre 8 result	

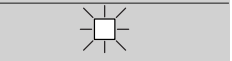
**Note** – The factory settings are highlighted in grey.

**TABLE 8 – Programming procedure (second level functions)**

<b>01.</b> Press and hold down the “Set” key for approx. 3 seconds.;	
<b>02.</b> Release the key when LED “L1” starts flashing;	
<b>03.</b> Press the “◀” or “▶” key to move the flashing LED to the LED representing the “input LED” of the parameter to be modified;	
<b>04.</b> Press and hold the “Set” key through to completion of point 06;	
<b>05.</b> Wait approx. 3 seconds, until the LED representing the current level of the parameter to be modified illuminates;	
<b>06.</b> Press keys “◀” or “▶” to move the LED representing the value of the parameter;	
<b>07.</b> Release the “Set” key;	
<b>08.</b> Wait 10 seconds (maximum time) to exit the programming mode.	

**Note** – During this procedure, points 03 to 07 need to be repeated when programming other parameters during the phase itself.

## 5.3 - Special functions

### 5.3.1 - Function: “Move anyway”

This function allows the automation to be operated even when any of the safety devices does not work correctly or is out of use.

The automation can be controlled in the “hold-to-run” mode. Proceed as follows:

- 01.** Send a command to operate the gate using a transmitter or a key selector, etc. If everything operates correctly, the gate will move normally, otherwise proceed as follows;
- 02.** within 3 seconds, activate the control again and keep it activated;
- 03.** after approximately 2 seconds, the gate will perform the required movement in “hold-to-run” mode; i.e. the gate will continue to move only as long as the control is activated.

If the safety devices do not operate, the flashing light flashes a few times to indicate the kind of problem (see chapter 6 - Table 10).

### 5.3.2 - Function: “Maintenance warning”

This function serves to indicate when the automation requires maintenance. The maintenance warning signal is given by way of a lamp connected to the S.C.A. (open gate light) output when this output is programmed as “Maintenance light”. The various warning lamp signals are shown in **Table 9**.

**Table 9 - “Maintenance light”**

Number of manoeuvres	Signal
<b>Below 80% of the limit</b>	Light on for 2 seconds at the start of the opening manoeuvre.
<b>Between 81% and 100% of the limit</b>	Light flashing for the entire duration of the manoeuvre.
<b>Beyond 100% of the limit</b>	Light flashing continuously.

To program the limit value of the maintenance operations, see **Table 8**.

## 5.4 - Deleting the memory

To delete the control unit memory and restore all factory settings, proceed as follows: press and hold keys “◀” and “▶” until leds L1 and L2 start flashing.

## 6 WHAT TO DO IF... (troubleshooting guide)

Some devices are able to emit signals that serve to recognise their state of operation or possible faults.

If a flashing light is connected to the FLASH output on the control unit, it will

flash at intervals of 1 second during a manoeuvre. If faults occur, the flashing light will emit a sequence of two shorter flashes separated by a 1 second pause. **Table 10** shows the cause and solution for each type of signal. The LEDs on the control unit also emit signals.

**Table 11** shows the cause and solution for each type of signal.

It is possible to verify faults that have occurred during the last 8 manoeuvres. See **Table 12**.

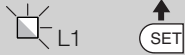





**TABLE 10 - Flashing light signals (FLASH)**

Flashes	Problem	Solution
1 short flash 1 second pause 1 short flash	Bluebus system error	At the start of the manoeuvre, the devices connected to Bluebus do not correspond to those recognized during the self-learning phase. One or more devices may be disconnected or faulty; check and, if necessary, replace them. In case of modifications repeat the device self-learning process (see paragraph 3.4).
2 short flashes 1 second pause 2 short flashes	Photocell activated	One or more photocells do not enable movement or have caused a movement inversion during travel; check to see if there are any obstructions.
3 short flashes 1 second pause 3 short flashes	Function activation "Obstacle detection" by force limiter	During the movement, the motors encountered excessive resistance; identify the cause and if necessary increase the level of force of the motors.
4 short flashes 1 second pause 4 short flashes	STOP input activation	At the start of the manoeuvre or during the movement, the STOP input was activated; identify the cause.
5 short flashes 1 second pause 5 short flashes	Error on internal parameters in control unit	Wait at least 30 seconds, then try giving a command and if necessary turn off the power supply. If the condition persists, there may be a malfunction and the electronic board must be replaced.
6 short flashes 1 second pause 6 short flashes	Maximum limit of consecutive manoeuvres or manoeuvres per hour exceeded.	Wait a few minutes until the manoeuvre limiting device falls to below the maximum limit.
7 short flashes 1 second pause 7 short flashes	Electric circuits fault	Wait at least 30 seconds, then try sending a command and if necessary turn off the power supply. If the condition persists, there may be a malfunction and the electronic board must be replaced.
8 short flashes 1 second pause 8 short flashes	A command is already present that disables execution of other commands	Check the type of command that is always present; for example, it could be a command from a timer on the "open" input.
9 short flashes 1 second pause 9 short flashes	The automation has been blocked by a "Block automation" command	Release the automation by giving the "Automation release" command.
10 short flashes 1 second pause 10 short flashes	"Obstacle detection" by encoder function activated	During the movement, the motors have been blocked by higher friction; identify the cause.

**TABLE 11 - Signals given by LEDs on control unit (fig. 7)**

LED	Problem	Solution
<b>BLUEBUS</b> Always off	Fault	Check that the control unit is powered. Check that the fuses have not blown: if they have, check the cause of the fault and replace with others with the same value
Always on	Serious fault	A serious fault has occurred: try disconnecting electrical power from the control unit. If the problem persists it will be necessary to replace the electronic board
1 flash per second	Everything normal	Control unit works correctly
2 quick flashes	Input status variation	Normal if one of the inputs (PP, STOP, OPEN, CLOSE) changes: photocells activated or a command given via a transmitter
Series of flashes separated by one second pause	Various	Refer to Table 10
<b>STOP</b> Always off	Activation of the devices connected to the STOP input	Check the devices connected to the STOP input
Always on	Everything normal	STOP input active
<b>S.S.</b> Always off	Everything normal	S.S. input not active
Always on	S.S. input activation	Normal if the device connected to the S.S. input is active
<b>OPEN</b> Always off	Everything normal	OPEN input not active
Always on	OPEN input activation	Normal if the device connected to the OPEN input is active
<b>CLOSE</b> Always off	Everything normal	CLOSE input not active
Always on	CLOSE input activation	Normal if the device connected to the CLOSE input is active
<b>L1 - L2</b> Slow flashing	Change in number of devices connected to Bluebus or device self-learning not performed	The device self-learning process must be performed (see paragraph 3.5)
<b>L3 - L4</b> Slow flashing	Change in self-learning of the motor types or the positions of the mechanical stops	Self-learning of the mechanical stop positions has not been performed

**TABLE 12 - Fault log**

01. Press and hold down the “Set” key for approx. 3 seconds;	
02. Release the key when LED “L1” starts flashing;	
03. Press keys “◀” or “▶” to move from the flashing LED to L8 LED (“input LED”) for the “Fault log” parameter;	
04. Press and hold the “Set” key through to completion of point 06;	
05. Wait approx. 3 seconds until the LEDs representing the levels corresponding to the manoeuvres with faults illuminate. The LED L1 indicates the result of the most recent manoeuvre while L8 indicates the eighth-to-last manoeuvre. If the LED is on this means that a fault has occurred; if the LED is off, everything is normal;	
06. Press keys “◀” and “▶” to select the required manoeuvre: the corresponding LED performs a number of flashes equal to those normally performed by the flashing light;	
07. Release the “Set” key.	

## 7 FURTHER DETAILS

The following optional accessories are available for the control unit MC824H: SMXI, OXI family receivers, Oview programmer, the Solemyo solar energy panel and the PS324 buffer battery.

### 7.1 - Connecting a radio receiver

The control unit has a connector for connecting radio receivers (optional accessories) belonging to the SMXI and OXI families. To connect a receiver, disconnect power from the control unit and proceed as shown in **fig. 8**. **Table 13** and **Table 14** show the commands corresponding to the outputs on the control unit.

**Table 13**

SMXI / SMXIS or OXI / OXIFM / OXIT / OXITFM in mode I or Mode II

Output no. 1	“S.S.” (Step by Step) <b>command</b>
Output no. 2	“Partial opening 1” <b>command</b>
Output no. 3	“Open” <b>command</b>
Output no. 4	“Close” <b>command</b>

**Table 14**

OXI / OXIFM / OXIT / OXITFM in extended mode II

No.	Command	Description
1	<b>Step by step</b>	“S.S.” (Step by Step) command
2	<b>Partial opening 1</b>	“Partial opening 1” command
3	<b>Open</b>	“Open” command
4	<b>Close</b>	“Close” command
5	<b>Stop</b>	Stops manoeuvre
6	<b>Apartment block Step by Step</b>	Apartment block control
7	<b>Step by Step high priority</b>	Gives command even when automation is blocked or commands are in progress
8	<b>Partial open 2</b>	Partial open (Opening of leaf M2 to 1/2 of normal opening)
9	<b>Partial open 3</b>	Partial open (Opening of two leaves to 1/2 of normal opening)
10	<b>Open and block automation</b>	It causes an opening manoeuvre, after which the automation is blocked; the control unit accepts no further commands with the exception of “Step by step high priority”, “Release” automation and (from Oview only) the commands “Release and close” and “Release and open”
11	<b>Close and block automation</b>	It causes a closure manoeuvre, after which the automation is blocked; the control unit accepts no further commands with the exception of “Step by step high priority”, “Release” automation and (from Oview only) the commands “Release and close” and “Release and open”
12	<b>Block automation</b>	It causes the manoeuvre to stop and the automation to block; the control unit accepts no further commands with the exception of “Step by step high priority”, “Release” automation and (from Oview only) the commands “Release and close” and “Release and open”.
13	<b>Release automation</b>	It causes the automation to be released and normal operation to resume
14	<b>Courtesy light timer on</b>	The Courtesy light comes on with timed turning off
15	<b>Courtesy light on-off</b>	The Courtesy light turns on and off in step-by-step mode

### 7.2 - Connecting Oview programming unit

Connector BusT4 on the control unit enables connection of the programming unit Oview which enables complete and rapid management of installation, maintenance and troubleshooting of any malfunctions of the whole automation system. To gain access to the connector, proceed as shown in **fig. 9** and connect the connector to its seat. The Oview can be connected simultaneously to a number of control units (up to 5 without any particular precautions, up to 60 following the relevant warnings) and can remain connected to the control unit during normal operation of the automation. In this case a specific “user” menu enables commands to be sent directly to the control unit. It is also possible to update the firmware. If an OXI family radio receiver is present in the control unit, Oview enables access to the parameters of the transmitters memorised in this receiver.

Further information is available in the instruction manual and the “Opera system book” manual.

### 7.3 - Connecting the Solemyo solar energy system

To connect the solar energy system see **fig. 10**.

**IMPORTANT! – When the automation is powered by the “Solemyo” system, it MUST NOT BE POWERED at the same time from the electrical mains.**

For other information, refer to the relevant instruction manual.

### 7.4 - Connecting model PS324 buffer battery

To connect the buffer battery, see **fig. 10**. For other information, refer to the relevant instruction manual.

Regular maintenance is needed to keep the level of safety constant and to ensure the maximum durability of the entire automation.

Maintenance must be performed in strict accordance with the safety provisions set out in this manual and with the requirements of applicable laws and standards.

**Important** – During maintenance and cleaning the control unit must be disconnected from the electrical power supply.

For devices other than the MC824H follow the instructions given in the relevant maintenance programmes.

For the MC824H scheduled maintenance must be performed no more than 6 months or 20,000 manoeuvres after previous maintenance.

To perform maintenance, proceed as follows:

01. Disconnect all electric power sources, including any buffer batteries;
02. Check all materials making up the control unit for wear, with particular attention to erosion or oxidation of parts; replace parts that are not in optimal condition;
03. Reconnect the power supply and perform the checks described in chapter 4.1 - Testing.

**This product is an integral part of the automation system it controls and must be disposed of along with it.**

As in the case of installation, likewise at the end of product lifetime the disassembly and scrapping operations must be performed by qualified personnel.

This product is made of various types of material, some of which can be recycled while others must be scrapped. Seek information on the recycling and disposal methods envisaged by the local regulations in your area for this product category.

**Important!** – Some parts of the product may contain polluting or hazardous substances which, if released to the environment, may cause serious damage to the environment or to human health.

As indicated by the symbol alongside, disposal of this product with domestic waste is strictly prohibited. Separate the waste into categories for disposal, according to the methods established by current legislation in your area, or return the product to the retailer when purchasing a new version.

**Important!** – Local legislation may impose heavy fines in the event of illegal disposal of this product.



#### Disposal of buffer battery (if present)

**Important!** – Even if discharged, the batteries may contain pollutant substances and therefore must NEVER be disposed of in normal waste collection points.

Dispose of according to separate waste collection methods as envisaged by current local standards.

## TECHNICAL CHARACTERISTICS OF THE PRODUCT

**WARNINGS:** • All technical characteristics stated refer to an ambient temperature of 20°C (±5°C). • Nice S.p.a reserves the right to modify the product at any time while maintaining the same functionalities and intended use.

<b>MC824H power supply</b> <b>MC824H/V1 power supply</b>	230 Vac (+10% -15%) 50/60 Hz 120 Vac (+10% -15%) 50/60 Hz
<b>Nominal power absorbed from mains</b>	200 W
<b>Power absorbed by control unit battery connector with "standby-All" operation</b> (including a receiver with SM type connector)	below 100 mW
<b>Flashing light output [*]</b>	1 "LUCYB" type flashing light (12 V, 21 W lamp)
<b>Electric lock output [*]</b>	1 max. 12 Vac max. 15 VA electric lock
<b>Gate open light output [*]</b>	one 24 V max. 4 W lamp (output voltage may vary between -30% and +50%, output may also control small relays)
<b>BLUEBUS output</b>	1 output with maximum load 15 Bluebus units (maximum 6 pairs of MOFB or MOFOB photocells assigned as Opening devices + max. 4 MOMB or MOTB control devices)
<b>STOP Input</b>	For normally closed, normally open or 8.2 kΩ constant resistance contacts in self-learning mode (a change from the memorised state prompts the "STOP" command)
<b>PP Input</b>	for normally open contacts (closure of the contact prompts the Step by Step command)
<b>OPEN Input</b>	for normally open contacts (closure of the contact prompts the OPEN command)
<b>CLOSE Input</b>	for normally open contacts (closure of the contact prompts the CLOSE command)
<b>Radio connector</b>	SM connector for SMXI, OXI and OXIFM family receivers
<b>Radio AERIAL input</b>	50 Ω for RG58 or similar type cable
<b>Programmable functions</b>	8 ON-OFF type functions and 8 adjustable functions
<b>Functions in self-learning mode</b>	<ul style="list-style-type: none"> <li>• Self-learning of devices connected to the BlueBus output</li> <li>• Self-learning of type of device connected to "STOP" terminal (NO, NC or 8.2 kΩ resistance contact)</li> <li>• Self-learning of leaf travel and automatic calculation of deceleration and partial opening points (vary according to installation)</li> </ul>
<b>Operating temperature</b>	from - 20 °C a + 50 °C
<b>Use in particularly acid, saline or potentially explosive atmospheres</b>	NO
<b>Protection rating</b>	IP 54 with enclosure intact
<b>Dimensions (mm)</b>	310 x 232 x H 122
<b>Weight (kg)</b>	4,1

[\*] The Flashing Light, Electric Lock and Gate Open Warning light outputs can be programmed with other functions (see "TABLE 5 - 1st level functions"; or via Oview programmer, see chapter 7.2). The electrical characteristics of the output vary according to programming:

**flashing light: 12Vdc, 21 Wmax lamp**

**electric lock: 12Vac 15 VAmx**

**other outputs (all types): 1 lamp or relay 24Vdc (-30 and +50%), 4 Wmax**

## CE declaration of conformity and declaration of incorporation of "quasi machine"

Declaration in accordance with the Directives: 2006/95/EC (LVD); 2004/108/CE (EMC); 2006/42/EC (MD) appendix II, part B

**Note** - The contents of this declaration correspond to declarations in the official document deposited at the registered offices of Nice S.p.a. and in particular to the last revision available before printing this manual. The text herein has been re-edited for editorial purposes. A copy of the original declaration can be requested from Nice S.p.a. (TV) I.

**Number:** 298/MC824H                      **Revision:** 4                      **Language:** EN

**Manufacturer's Name:** NICE S.p.A.  
**Address:** Via Pezza Alta n° 13, 31046 Rustignè di Oderzo (TV) Italy

**Person authorised to draw up technical documentation:** Sig. Oscar Marchetto  
**Type of product:** 2-motor control unit (24 Vdc)  
**Model / Type:** MC824H  
**Accessories:** Radio receiver SMXI, OVIEW unit

The undersigned, Luigi Paro, in the role of Managing Director, declares under his sole responsibility, that the product specified above conforms to the provisions of the following directives:

- Directive 2006/95/EC OF THE EUROPEAN PARLIAMENT AND COUNCIL of 12 December 2006 regarding the approximation of member state legislation related to electrical material destined for use within specific voltage limits, according to the following harmonised standards:  
EN 60335-1:2002 + A1:2004 + A11:2004 + A12:2006 + A2:2006 + A13:2008, EN 60335-2-103:2003
- DIRECTIVE 2004/108/EC OF THE EUROPEAN PARLIAMENT AND COUNCIL of 15 December 2004 regarding the approximation of member state legislation related to electromagnetic compatibility, repealing directive 89/336/EEC, according to the following standards:  
EN 61000-6-2:2005, EN 61000-6-3:2007

The product also complies with the following directives according to the requirements envisaged for "quasi machinery":

- Directive 2006/42/EC THE EUROPEAN PARLIAMENT AND COUNCIL of 17 May 2006 regarding machinery and which amends directive 95/16/EC (recasting)
- It is hereby declared that the pertinent technical documentation has been compiled in compliance with appendix VII B of directive 2006/42/EC and that the following essential requirements have been observed: 1.1- 1.1.2- 1.1.3- 1.2.1-1.2.6- 1.5.1-1.5.2- 1.5.5- 1.5.6- 1.5.7- 1.5.8- 1.5.10- 1.5.11
- The manufacturer undertakes to transmit to the national authorities, in response to a motivated request, all information regarding the "quasi-machine", while maintaining full rights to the related intellectual property.
- Should the "quasi machine" be put into service in a European country with an official language other than that used in this declaration, the importer is obliged to arrange for the relative translation to accompany this declaration.
- The "quasi-machine" must not be used until the final machine in which it is incorporated is in turn declared as compliant, if applicable, with the provisions of directive 2006/42/EC.

The product also complies, within the constraints of applicable parts, with the following standards:

EN 60335-1:2002 + A1:2004 + A11:2004 + A12:2006 + A2:2006 + A13:2008+A14:2010 + EN 60335-2-103:2003

Oderzo, 19.09.11

Luigi Paro (Managing Director)



## Dichiarazione CE di conformità e dichiarazione di incorporazione di "quasi macchina"

Dichiarazione in accordo alle Direttive: 2006/95/CE (LVD); 2004/108/CE (EMC); 2006/42/CE (MD) allegato II, parte B

**Nota** - Il contenuto di questa dichiarazione corrisponde a quanto dichiarato nel documento ufficiale depositato presso la sede di Nice S.p.a., e in particolare, alla sua ultima revisione disponibile prima della stampa di questo manuale. Il testo qui presente è stato riadattato per motivi editoriali. Copia della dichiarazione originale può essere richiesta a Nice S.p.a. (TV) I.

**Numero:** 298/MC824H                      **Revisione:** 4                      **Lingua:** IT

**Nome produttore:** NICE S.p.A.  
**Indirizzo:** Via Pezza Alta n° 13, 31046 Rustignè di Oderzo (TV) Italia

**Persona autorizzata a costituire la documentazione tecnica:** Sig. Oscar Marchetto  
**Tipo di prodotto:** centrale di comando a 2 motori 24 Vd.c.  
**Modello/Tipo:** MC824H  
**Accessori:** Ricevente radio SMXI, unità OVIEW

Il sottoscritto Luigi Paro in qualità di Amministratore Delegato, dichiara sotto la propria responsabilità che il prodotto sopra indicato risulta conforme alle disposizioni imposte dalle seguenti direttive:

- Direttiva 2006/95/CE DEL PARLAMENTO EUROPEO E DEL CONSIGLIO del 12 dicembre 2006 concernente il ravvicinamento delle legislazioni degli Stati membri relative al materiale elettrico destinato ad essere adoperato entro taluni limiti di tensione, secondo le seguenti norme armonizzate:  
EN 60335-1:2002 + A1:2004 + A11:2004 + A12:2006 + A2:2006 + A13:2008, EN 60335-2-103:2003
- DIRETTIVA 2004/108/CE DEL PARLAMENTO EUROPEO E DEL CONSIGLIO del 15 dicembre 2004 concernente il ravvicinamento delle legislazioni degli Stati membri relative alla compatibilità elettromagnetica e che abroga la direttiva 89/336/CEE, secondo le seguenti norme armonizzate:  
EN 61000-6-2:2005, EN 61000-6-3:2007

Inoltre il prodotto risulta essere conforme alla seguente direttiva secondo i requisiti previsti per le "quasi macchine":

Direttiva 2006/42/CE DEL PARLAMENTO EUROPEO E DEL CONSIGLIO del 17 maggio 2006 relativa alle macchine e che modifica la direttiva 95/16/CE (rifusione)

- Si dichiara che la documentazione tecnica pertinente è stata compilata in conformità all'allegato VII B della direttiva 2006/42/CE e che sono stati rispettati i seguenti requisiti essenziali: 1.1- 1.1.2- 1.1.3- 1.2.1-1.2.6- 1.5.1-1.5.2- 1.5.5- 1.5.6- 1.5.7- 1.5.8- 1.5.10- 1.5.11
- Il produttore si impegna a trasmettere alle autorità nazionali, in risposta ad una motivata richiesta, le informazioni pertinenti sulla "quasi macchina", mantenendo impregiudicati i propri diritti di proprietà intellettuale.
- Qualora la "quasi macchina" sia messa in servizio in un paese europeo con lingua ufficiale diversa da quella usata nella presente dichiarazione, l'importatore ha l'obbligo di associare alla presente dichiarazione la relativa traduzione.
- Si avverte che la "quasi macchina" non dovrà essere messa in servizio finché la macchina finale in cui sarà incorporata non sarà a sua volta dichiarata conforme, se del caso, alle disposizioni della direttiva 2006/42/CE.

Inoltre il prodotto risulta conforme, limitatamente alle parti applicabili, alle seguenti norme:

EN 60335-1:2002 + A1:2004 + A11:2004 + A12:2006 + A2:2006 + A13:2008+A14:2010 + EN 60335-2-103:2003

Oderzo, 19 Settembre 2011

Luigi Paro (Amministratore Delegato)



# Instructions and warnings for the user

Before using the automation for the first time, ask the installer to explain the origin of residual risks and devote a few minutes to reading this user instruction and warning manual given to you by the installer. Keep the manual for reference when in doubt and pass it on to new owners of the automation.

**IMPORTANT! – Your automation is a machine that performs your commands faithfully; negligent or improper use may constitute a hazard.**

**– Never activate automation controls if persons, animals or objects are present in the operating range.**

**– NEVER touch parts of the automation while the gate or door is moving!**

**– Photocells are not safety devices but safety aids. They are constructed with very reliable technology but in extreme situations they may malfunction or even break. In some cases this malfunction may not be immediately evident. For this reason, observe the following warnings when using the automation:**

- **Pass through the gate or door only when it is completely open and the leaves have stopped moving.**
- **NEVER pass through while the gate or door is closing!**
- **Periodically check correct operation of the photocells.**

• **Children:** an automation system guarantees a high level of safety, using a special detection system to prevent movement in the presence of persons or objects. Nonetheless, it is advisable to ensure that children do not play in the vicinity of the automation. To prevent the risk of accidental activation, do not leave the remote controls within the reach of children **It is not a game!**

• The product should not be used by children or people with impaired physical, sensorial or mental capacities or who have not received adequate training in the safe use of the product.

• **Malfunctions:** if the automation is seen to perform abnormally, disconnect the electrical power supply from the system and manually release the gearmotor (see instruction manual) to operate the gate manually. Never attempt to perform repairs; contact your local installer for assistance.

• **Never modify the system or the control unit programming and adjustment parameters: this is the responsibility of the installer.**

• **Power supply failure or absence:** while waiting for the installer or the electrical power supply to return, the automation can still be used even if the system is not equipped with a buffer battery: manually release the gearmotor (see instruction manual) and move the gate leaf manually as required.

• **Safety devices disabled:** the automation can be operated even when a safety device does not work correctly or is out of use. The gate can be controlled in the “**hold-to-run**” mode. Proceed as follows:

- 01.** Send a command to operate the gate using a transmitter or a key selector, etc. If everything operates correctly, the gate will move normally, otherwise proceed as follows;
- 02.** Within 3 seconds, activate the control again and keep it activated;
- 03.** After approximately 2 seconds, the gate will perform the required movement in “**hold-to-run**”; mode; i.e. the gate will continue to move only as long as the control is activated.

**IMPORTANT! – If the safety devices are out of use, it is advisable to have them repaired as quickly as possible by a qualified technician.**

• Testing, periodic maintenance and any repairs must be documented by the person performing the operations and the relevant documents must be kept by the system owner. The only operations that can be performed by the user are to clean the photocell lenses (use a soft and slightly damp cloth) and remove any leaves or stones that may obstruct the automation. **Important** – To prevent the door from being activated accidentally, before proceeding release the automation man-

ually (as described in the relevant manual).

• **Maintenance:** Regular maintenance (at least every 6 months) is needed to keep the level of safety constant and to ensure the maximum durability of the entire automation. **Checks, maintenance and repairs must be performed exclusively by qualified personnel.**

• **Disposal:** At the end of the automation’s lifetime, ensure that it is disposed by qualified personnel and that the materials are recycled or scrapped according to current local standards.

• **If the automation has been blocked by a “Block automation” command:** after sending a command, the gate does not move and the flashing light emits 9 short flashes.



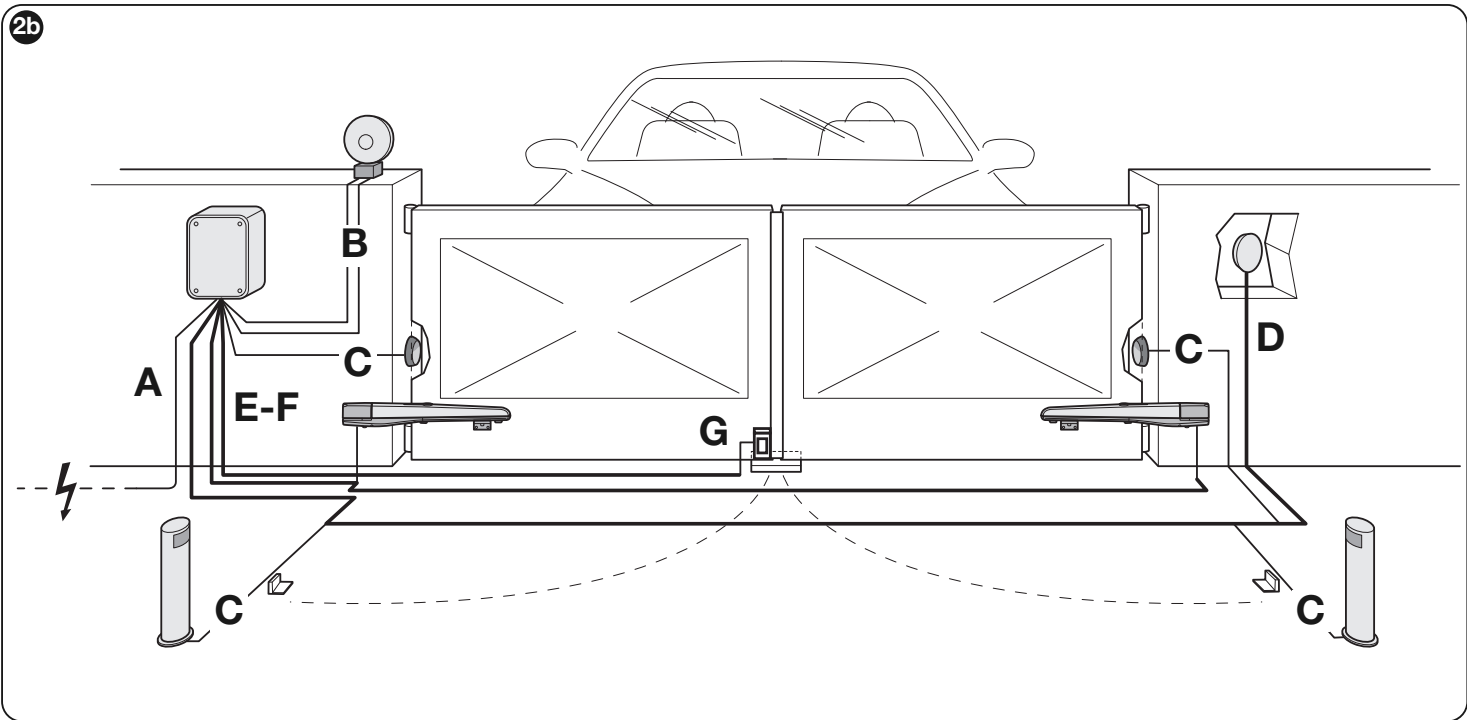
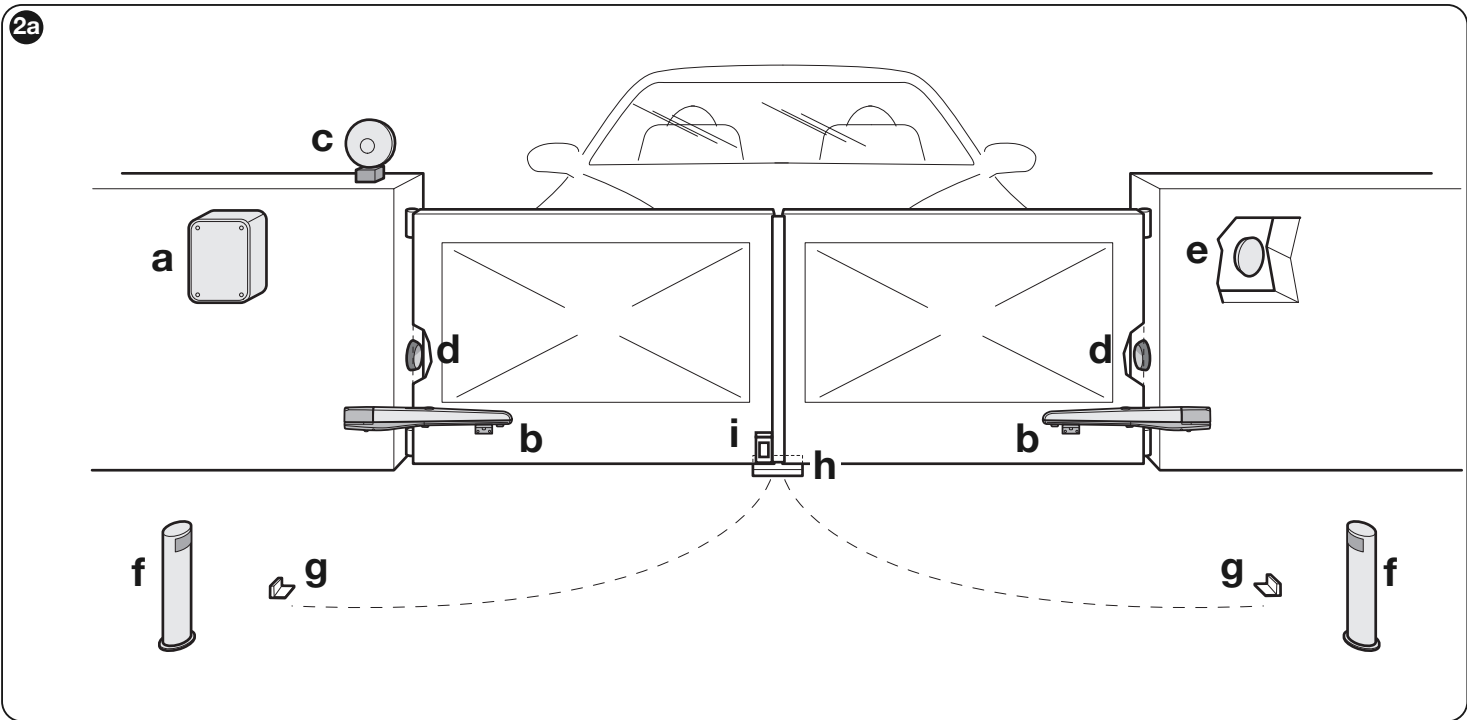
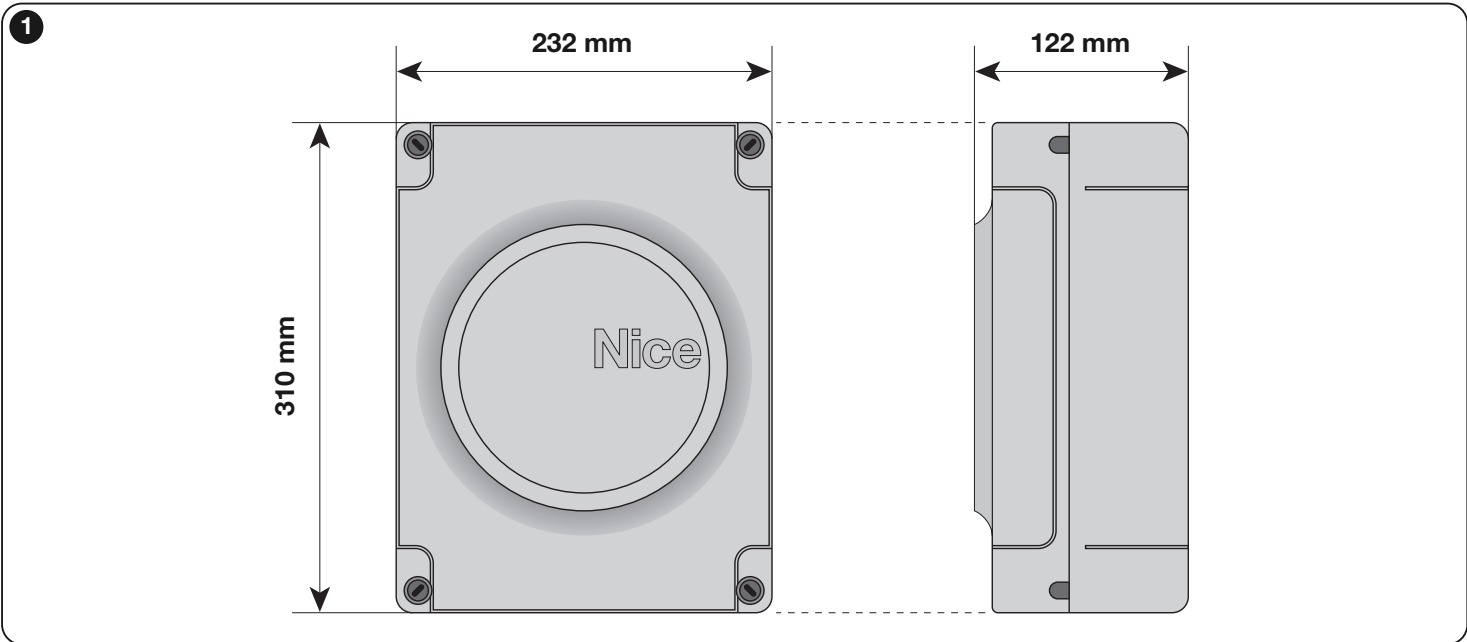

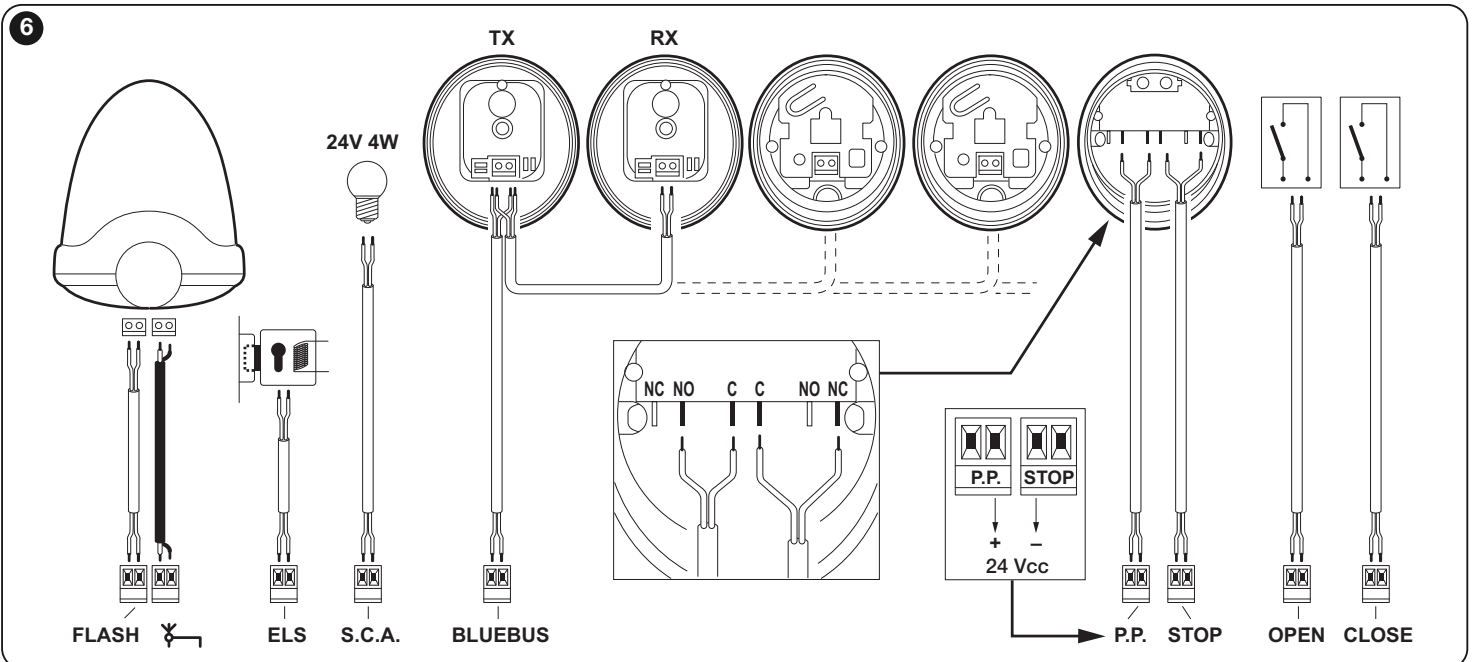
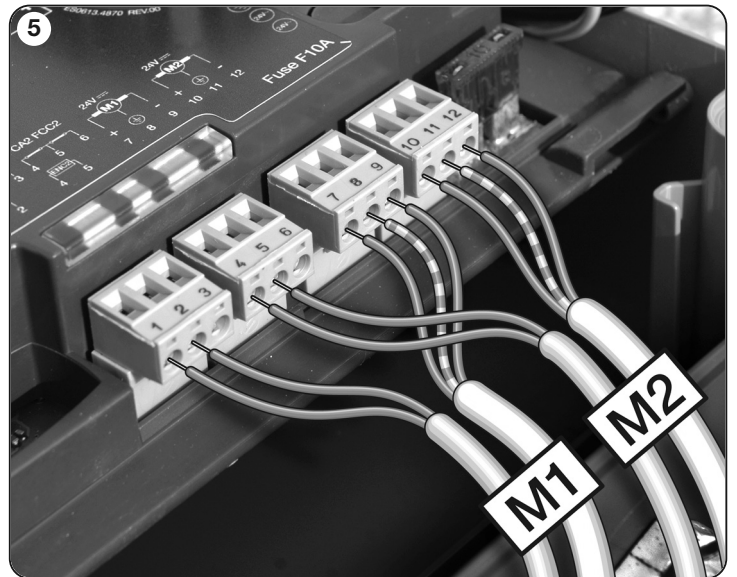
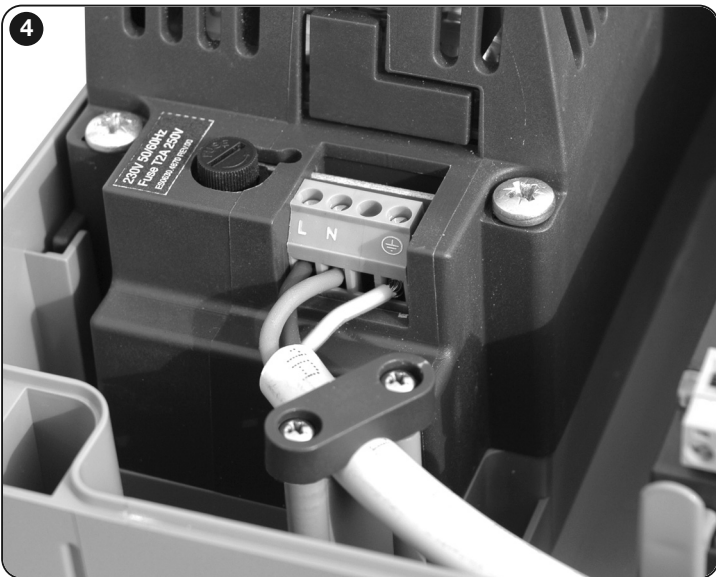
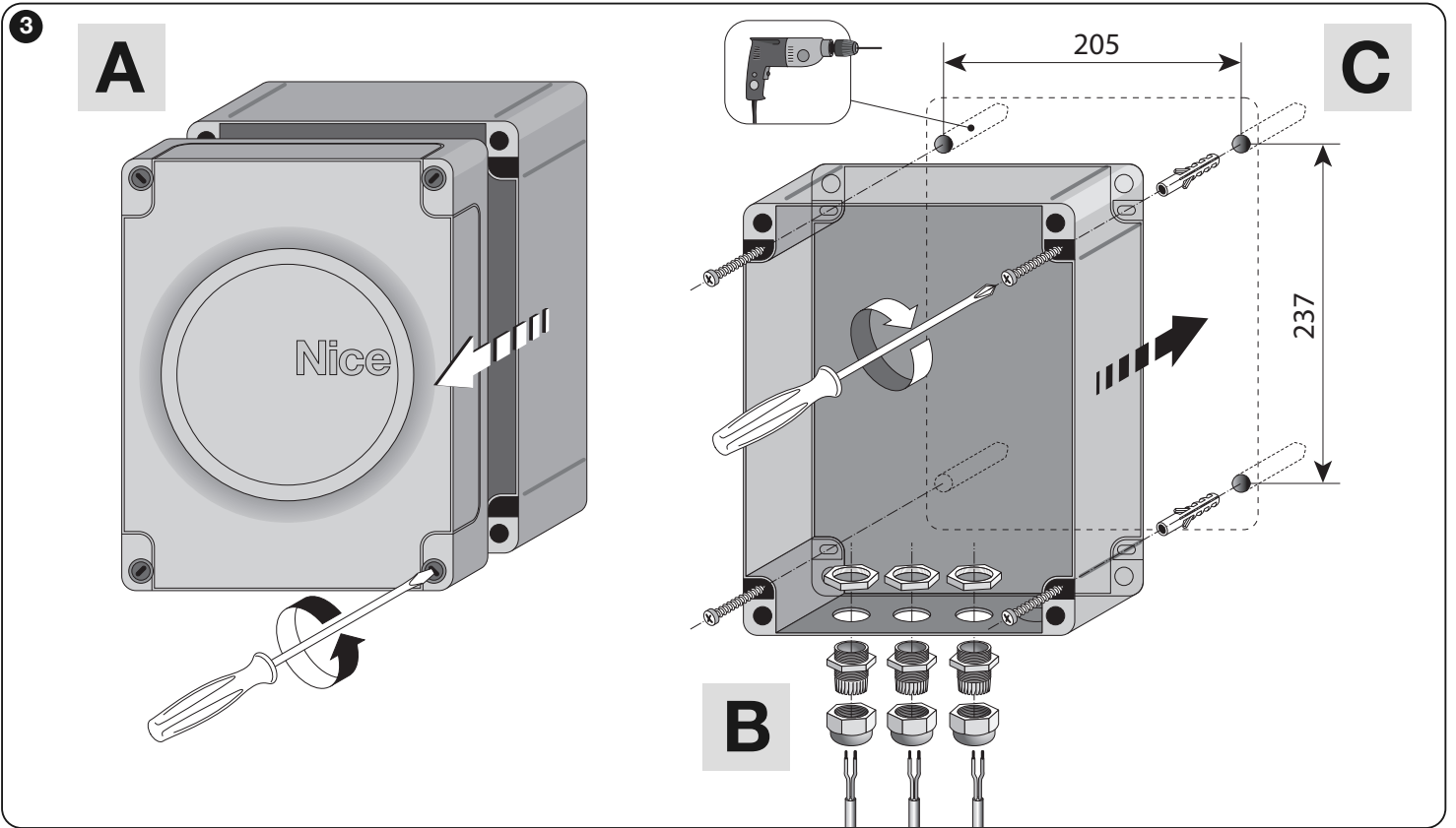



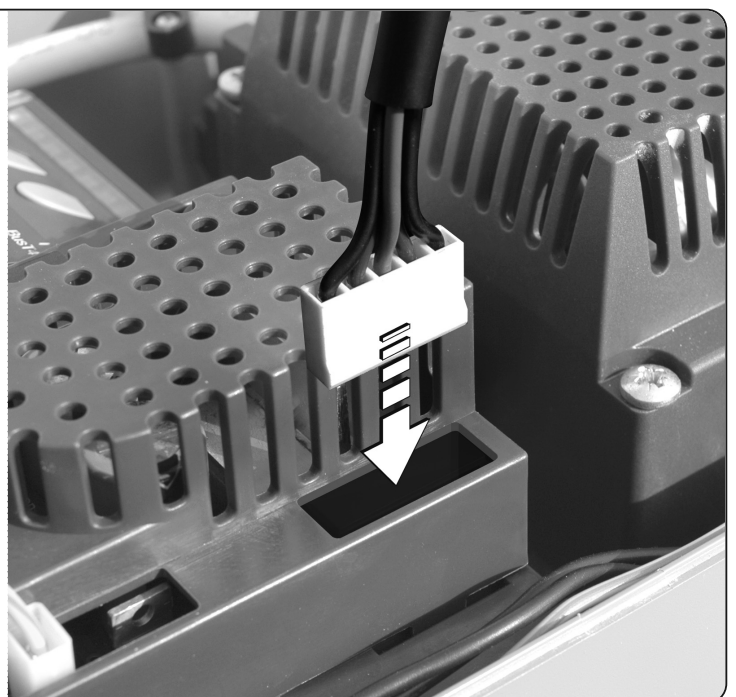
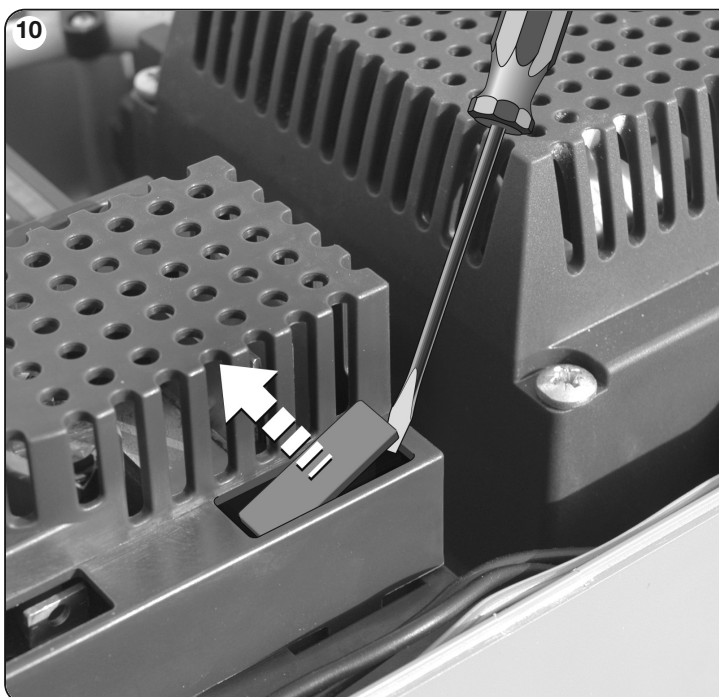
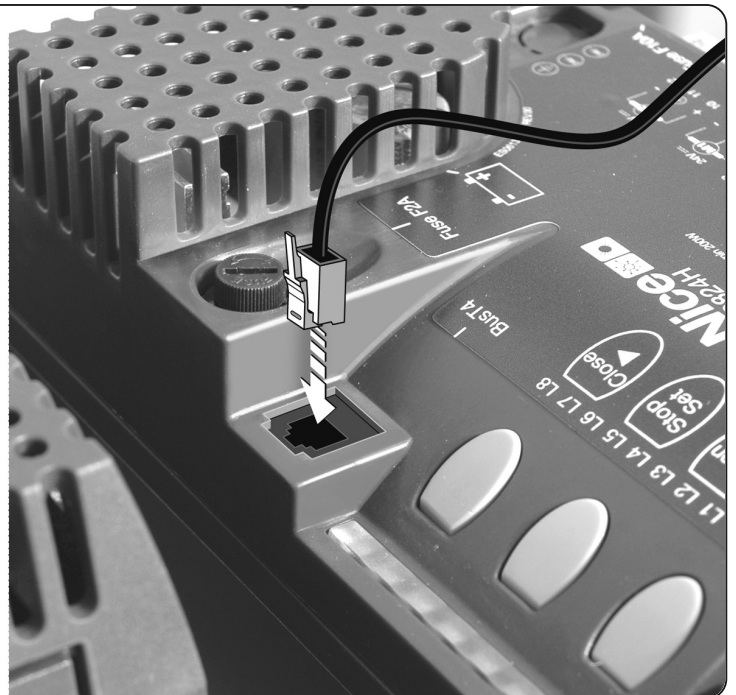
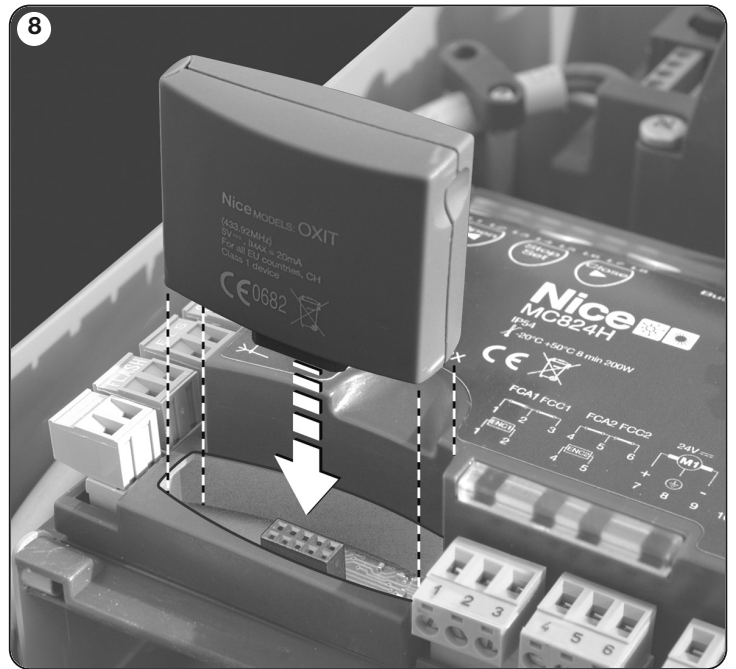
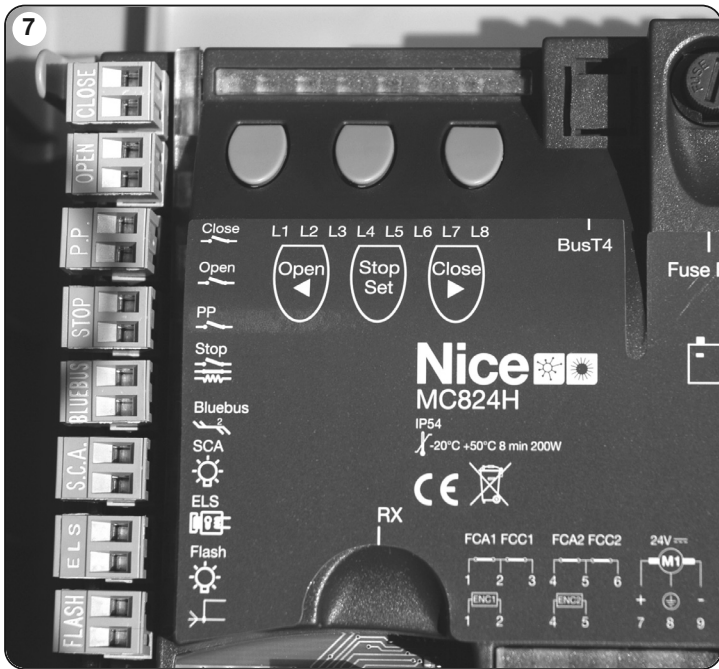

**Nice**

**Nice SpA**  
Oderzo TV Italia  
info@niceforyou.com

[www.niceforyou.com](http://www.niceforyou.com)

IST269R02.4850\_15-09-2011

CE



MOFB-MOFB  
photocells

# Moonbus

**Instructions and warnings for the fitter**

**Istruzioni ed avvertenze per l'installatore**

**Instructions et recommandations pour l'installateur**

**Anweisungen und Hinweise für den Installateur**

**Instrucciones y advertencias para el instalador**

**Instrukcje i ostrzeżenia dla instalatora**

**Aanwijzingen en aanbevelingen voor het installeren**

COMPANY  
WITH QUALITY SYSTEM  
CERTIFIED BY DNV  
=ISO 9001/2000=



## 1) Warnings

**⚠ This manual has been especially written for use by qualified fitters. No information given in this manual can be considered as being of interest to end users! This manual refers to MOFB-MOFOB only and cannot be used for different products.**

Read the instructions carefully before installing this product. Improper use of the said product or errors made during connection may jeopardise the correct operation of the device and the safety of the persons using it.

- The photocell must operate exclusively via direct TX-RX interpolation. It must not be used for reflection purposes.
- The photocell must be fastened securely to a rigid surface, which does not vibrate.
- Use the wires specified in the manuals for control units for the electrical connections.
- The MOFB-MOFOB photocells can only be connected up to control units which use "BlueBus" technology.

## 2) Description and Intended Use

The MOFB and MOFOB photocells are detectors (type D according to EN standard EN 12453) which can be used for automations for gates. They reveal obstacles situated on the optical axis between the transmitter (TX) and receiver (RX).

The photocells are equipped with a "BlueBus" communication system. This means they can easily be connected up to the control unit of all the devices using two wires only. All the photocells are quite simply connected in parallel, and the addressing jumpers selected according to the function required (see Table 1).

The non-adjustable version of the MOFB can be used as long as the surface the device will be fastened to is flat and allows correct TX-RX centring. The manufacturers recommend using the adjustable MOFOB version whenever this centring is not directly possible.

The MOFB and MOFOB photocells can be used along with the new "FT210B" series of devices (see figures 2a and 2b). The FT210B device uses the "BlueBUS" technology and resolves problems related to the electrical connection of sensitive edges on the mobile leaf (for further details consult the FT210B use manual).

## 3) Installation

**⚠ Only carry out installation work once the electricity supply to the system has been switched off. Disconnect any buffer batteries present.**

Begin the installation process by checking the following points:

1. As it is not possible to adjust the orientation when using fixed MOFB photocells, fitters must check that the surface the device will be fastened to will enable correct TX-RX centring. Fasten the photocells as shown in Figures 1a and 1b.
2. Position the photocells on the basis of their detection functions according to the type of automation used. Check the position in Figures 2, 3 and 4, and fit the jumpers as per Table 1. If the photocell needs to be used as an

opening device (see figures 2a, 2b, 3, 4 and the FA1 and FA2 addresses in table 1), cut the jumper between points "A" both on the TX and on the RX as shown in fig. 5.

3. Connect the electric cable to the appropriate TX and RX terminals. From an electrical viewpoint, TX and RX must be both connected in parallel as shown in Figure 5, and to the "BlueBus" terminal of the interfaces or control units. It is not necessary to observe any polarity.

## 4) Addressing and recognition of devices

When addressing using the special jumpers, the special "BlueBus" communication system enables the control unit to recognise the photocells and assign them with the correct detection function. Addressing must be carried out on both the TX and RX (and the jumpers set in the same way). Ensure there are no other pairs of photocells with the same address.

1. Address the photocells on the basis of the function required, setting the jumpers as shown in Table 1. Any unused jumpers must be stored in their proper compartment ready for future use, as shown in Figure 6.

**Note:** Refer to the instruction manual for control units and command interfaces with "BlueBus" technology for a detailed description of the various operations carried out for each kind of addressing.

**Note:** to rectify interference problems between the various "BlueBUS" devices, position the transmitters and receivers as shown in figures 2a and 2b.

2. Programme the devices using the control unit as described in the paragraph entitled "Recognition of connected devices" in the instruction manual of the various "BlueBus" interfaces or control units.

**Note:** If the photocell is used to replace an already existing one, the jumpers must be set exactly as they were in the old photocell. It is not necessary to carry out the recognition phase.

3. **Adjusting the orientation:** it is possible to adjust the orientation of the adjustable MOFOB photocell. This enables the user to achieve a perfect alignment, even if the fastening is not excellent. Proceed as per Figure 8 in order to regulate the orientation. Loosen the screw slightly and move the mobile part slowly. Then tighten the screw. Follow the signals of the "L" indicator: the slower the flashes, the better the centring.

The best centring has been achieved for both the MOFB and MOFOB versions when the indicator flashes very slowly, although performance is also acceptable when flashes are simply slow. However, the centring is at risk when the indicator flashes quickly.

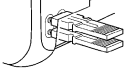
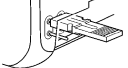
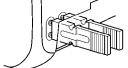
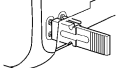
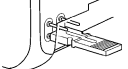
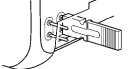
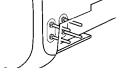
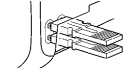
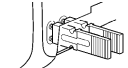
Table 1	
Photocell	Jumpers
FOTO	
FOTO II	
FOTO 1	
FOTO 1 II	
FOTO 2	
FOTO 2 II	
FOTO 3	
FA1 (Cut jumper A on the TX and RX as shown in fig. 5)	
FA2 (Cut jumper A on the TX and RX as shown in fig. 5)	

## 5) Testing and checking operation

After the recognition phase, check that the LED on the photocell starts flashing (both on TX and RX). Check Table 2 for the state of the photocell based on the way LED "L" flashes.

Table 2

LED "L"	Status	Action
Off	The photocell is either not powered or is faulty	Make sure the voltage for the photocell terminals is approximately 8-12 Vdc. If the voltage is correct, the photocell is probably broken.
3 quick flashes and a second's pause	Device not recognised by the control unit	Repeat the learning procedure on the control unit. Make sure that all the photocell pairs have different addresses
Very slow flashing	The TX transmits regularly The RX receives a perfect signal.	Normal operation
Slow flashing	The RX receives a fair signal	Normal operation
Quick flashing	The RX receives a poor signal	Normal operation. However, it is best to check the TX-RX alignment and make sure the glasses are clean
Very quick flashing	The RX receives a very poor signal	It is at the very limit of normal operation. Check the TX-RX alignment and make sure the glasses are clean.
Always ON	The RX does not receive any signal at all	Make sure that the LED on TX flashes once slowly. Check to see if there is an obstacle between TX and RX. Check the TX-RX alignment

**Warning:** After you have added or removed any photocells, the automation system must be tested again according to the directions contained in the installation manual.

To check the photocells and make sure that there is no interference with other devices, pass a 5 cm diameter, 30 cm long cylinder on the optical axis, first near TX, then near RX and finally at the mid-point between them (shown in Figure 9) and make sure that in all these cases the device is triggered, switching from the active to the alarm status and vice-versa; finally, that it causes the

intended action in the control unit, for example that it causes the reversal of the movement during the closing manoeuvre.

To check the photocells as an optical presence sensor (type D), according to the EN 12445 standard, is performed with the 700x300x200mm test parallelepiped with 3 opaque black sides and 3 polished white sides or mirrored as shown in figure 10 following that stipulated by chapter 7 of the EN 12445:2000 standard (or enclosure A of prEN 12445:2005).

## 6) Maintenance

The photocells do not require any special maintenance work. However, it is necessary to check them at least once every six months in order to evaluate their condition (presence of damp, oxides, etc.). The outer covering and lenses must be cleaned, then testing carried out again, as described in the previous paragraph.

The photocells have been studied and designed in order that they will operate in normal conditions for at least 10 years. It is, therefore, necessary to increase the frequency of the maintenance work carried out on the said photocells after this period of time has elapsed.

### 6.1) Disposal

As for the installation, the disposal of the product at the end of its effective life, must be performed by qualified personnel. This product is made of various types of material, some of which can be recycled while others must be disposed of. Enquire about the recycling or disposal systems available for this product category in compliance with regulations locally in force.

**Warning:** some parts of the product may contain polluting or hazardous substances that, if incorrectly disposed of, could have a damaging effect on the environment or on the health of individuals.

As indicated by the symbol in figure 11, this product must not be disposed of in household waste. Perform "separated collection" for disposal in compliance with regulations locally in force, or return the product to the manufacturer when purchasing a replacement.



Heavy fines may be imposed by local laws for the illegal disposal of this product.

## 7) Technical characteristics

Nice S.p.a., in order to improve its products, reserves the right to modify their technical characteristics at any time without prior notice. In any case, the manufacturer guarantees their functionality and fitness for the intended purposes. Note: all technical specifications refer to a temperature of 20°C.

Product type	Detector for gate and door automation systems (type D according to EN standard 12453), consisting in a "TX" transmitter and "RX" receiver.
Technology employed	TX-RX direct optical interpolation with modulated infrared ray.
Power supply/output	The device can only be connected to "BlueBus" networks, from which it receives its power supply and sends output signals.
Absorbed power	1 "BlueBus" unit.
Detection capacity	Opaque objects (larger than 50 mm) located on the optical axis between TX and RX, which move more slowly than 1.6m/s.
TX transmission angle	20° +/- 25%
RX reception angle	Approximately 20°.
Adjustability of the MOFOB photocell	Approximately 30° along the horizontal and vertical axes.
Useful range	Up to 15m for a maximum TX-RX misalignment of ± 5° (the device can detect and signal an obstacle even in particularly bad weather conditions).
Maximum range (under optimum conditions)	Up to 30m for a maximum TX-RX misalignment of ± 5°.
Maximum cable length	Up to 50 m.
Addressing possibility	Up to 7 detectors with the protection function, and 2 with the opening command function. The automatic synchronism prevents any interference among the various detectors.
Use in acid, saline or potentially explosive atmospheres	No
Mounting	Vertically wall-mounted
Protection class for casing	IP55
Operating temperature	20 ±55°C
Dimensions / weight	for MOFB 69 x 78 h 25mm / 50g for MOFOB 69 x 78 h 37mm / 75g

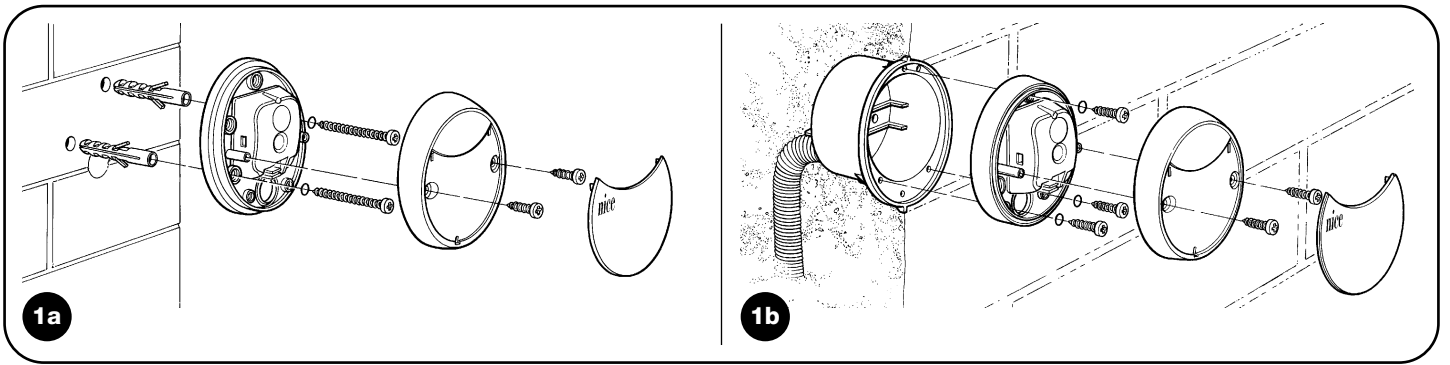

1a

1b

**SINGLE LEAF SLIDING GATE**  
**CANCELLO SCORREVOLE AD ANTA SINGOLA**  
**PORTAIL COULISSANT À UN SEUL VANTAIL**  
**EINTEILIGES SCHIEBETOR**  
**PUERTA DE CORREDERA DE UNA HOJA**  
**BRAMA PRZESUWNA Z JEDNYM SKRZYDŁEM**  
**SCHUIFPOORT MET ENKELE VLEUGEL**

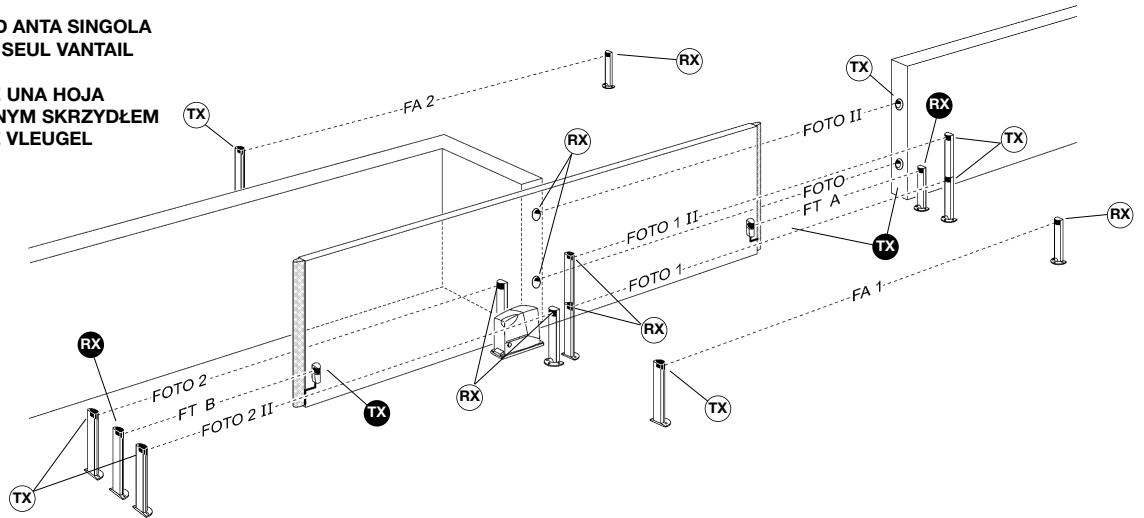

2a

**SYNCHRONISED LEAFS SLIDING GATE**  
**CANCELLO SCORREVOLE AD ANTE CONTRAPPOSTE**  
**PORTAIL COULISSANT À VANTAUX OPPOSÉS**  
**SCHIEBETOR MIT ENTGEGENGESETZT ANGEBRACHTEN TORFLÜGELN**  
**PUERTA DE CORREDERA DE HOJAS CONTRAPUESTAS**  
**BRAMA PRZESUWNA Z DWOMA PRZECIWLĘŻĄCYMI SKRZYDŁAMI**  
**SCHUIFPOORT MET TEGENGESTELDE VLEUGELS**

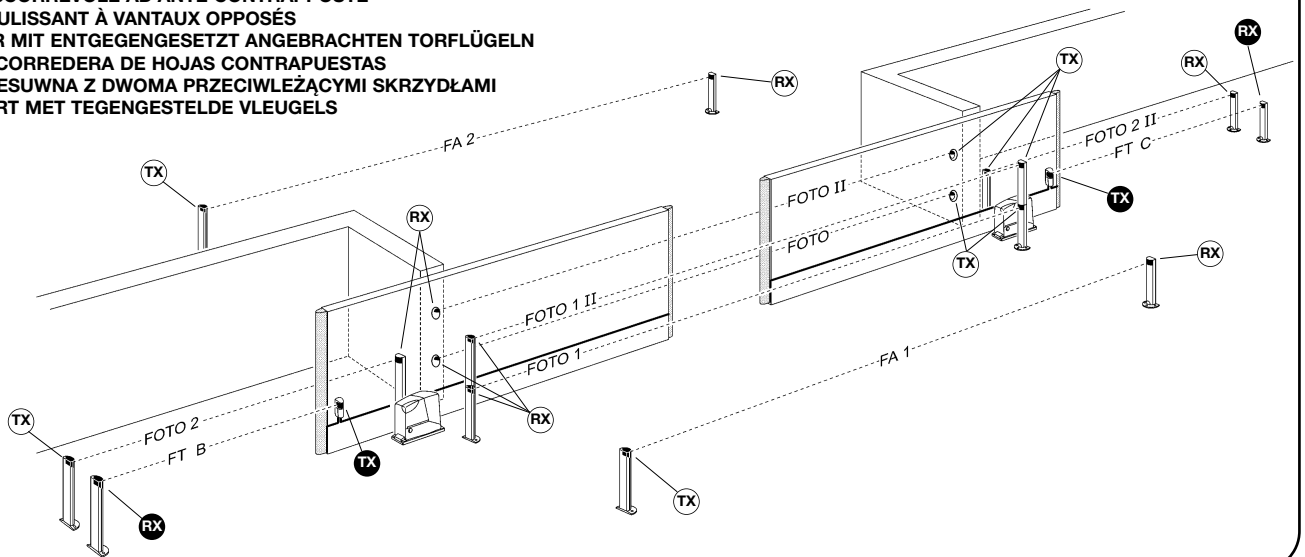

2b

**SWING GATE**  
**CANCELLO A BATTENTE**  
**PORTAIL BATTANT**  
**DREHTOR**  
**PUERTA DE BATIENTE**  
**BRAMA SKRZYDŁOWA**  
**KANTELDEUR VOOR GARAGE**

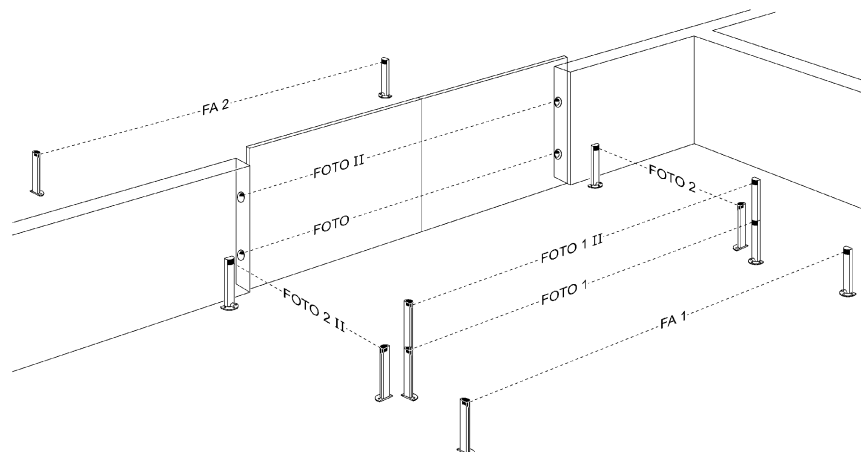

3

SECTIONAL DOOR  
 GARAGE SEZIONALE  
 PORTE SECTIONNELLE  
 SEKTIONALTOR  
 GARAJE SECCIONAL  
 BRAMA GARAŻOWA SEKCYJNA  
 SECTIONAALGARAGEDEUR

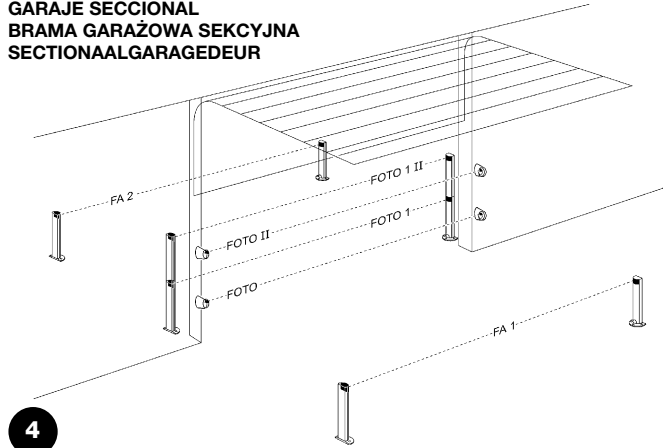

4

UP & OVER GARAGE DOORS  
 GARAGE BASCULANTE  
 PORTE DE GARAGE BASCULANTE  
 GARAGENKIPPTOR  
 GARAJE BASCULANTE  
 GARAZ BRAMA UCHYLNA  
 KANTELDEUR VOOR GARAGE

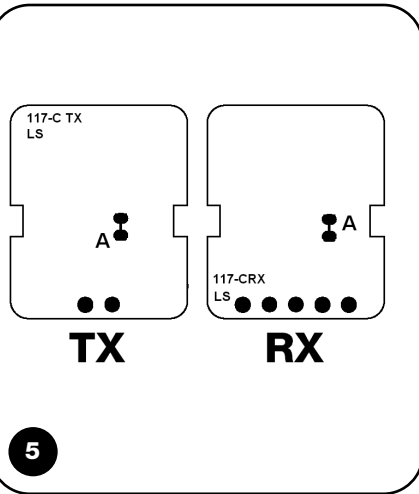
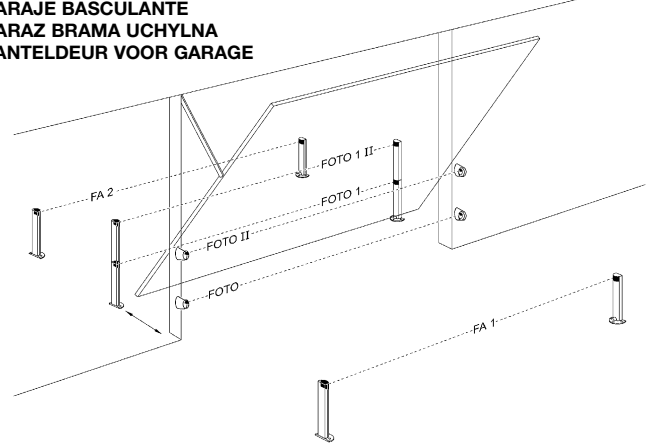

5

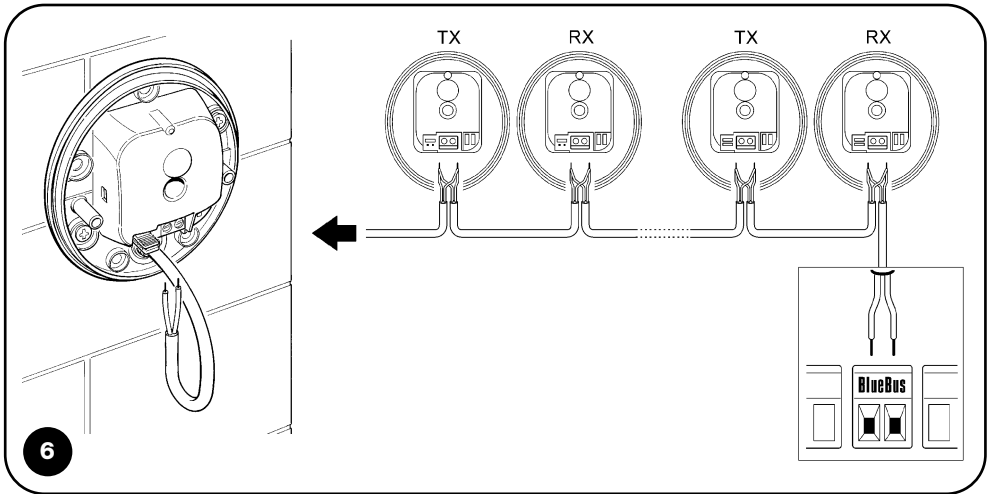

6

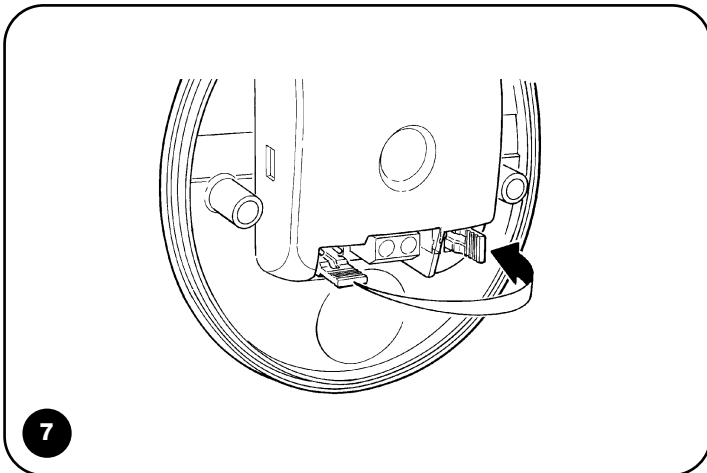

7

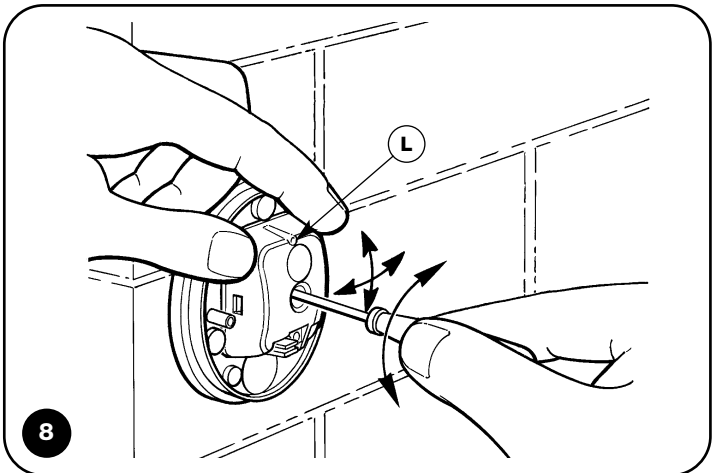

8

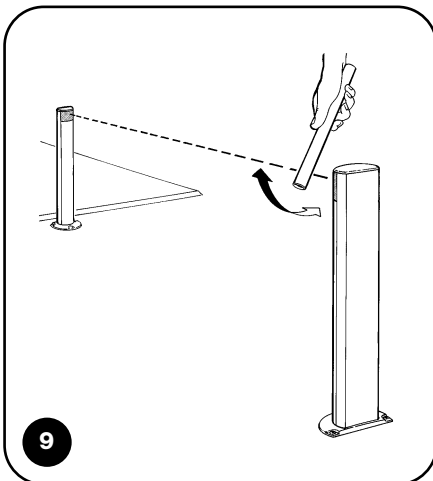

9

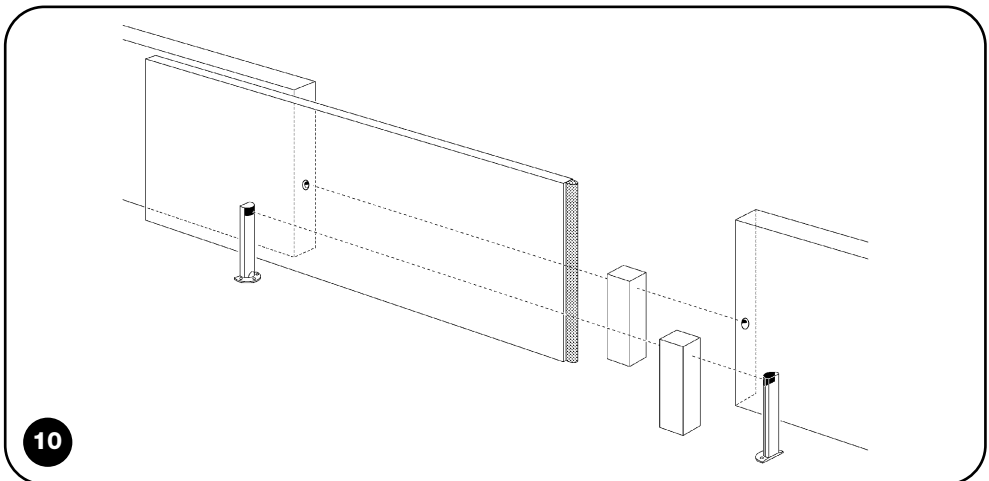

10

# Dichiarazione CE di conformità / EC declaration of conformity

(Secondo la Direttiva 89/336/CEE) (According to Directive 89/336/EEC)

**Nota: il contenuto di questa dichiarazione di conformità corrisponde all'ultima revisione aggiornata alla data di edizione del presente documento; eventualmente riadattato per motivi editoriali. La versione integrale ed aggiornata della presente dichiarazione è depositata presso la sede di Nice S.p.a.**

*Note: the content of this declaration of conformity correspond to the last revision updated on the edition date of the present document; readapted for editorial reasons. The integral and updated version of the present document is held at the Head Offices of Nice S.p.a.*

**Numero / Number: 177/MOFB-MOFOB**

**Data / Date: 20/10/2005**

**Revisione / Revision: 1**

**Il sottoscritto Lauro Buoro, Amministratore Delegato, dichiara che il prodotto**

*The undersigned Lauro Buoro, General Manager of the following producer, declares that the product*

**Nome produttore / Producer name:**

NICE S.p.a.

**Indirizzo / Address:**

Via Pezza Alta 13, 31046 Z.I. Rustignè - ODERZO - ITALY

**Modello / Model:**

MOFB, MOFOB

**Risulta conforme a quanto previsto dalle seguenti direttive comunitarie, così come modificate dalla Direttiva 93/68/CEE del consiglio del 22 Luglio 1993:**

*Complies with the following community directives, as modified from Directive 93/68/EEC of the Council of the 22 July 1993.*

- 89/336/CEE; DIRETTIVA 89/336/CEE DEL CONSIGLIO del 3 maggio 1989, per il riavvicinamento delle legislazioni degli Stati membri relative alla compatibilità elettromagnetica. / 89/336/CEE; Council Directive of 3 May 1989 on the approximation of the laws of the Member States relating to Electromagnetic Compatibility).

Secondo le seguenti norme: EN 61000-6-2; EN 61000-6-3 / *Complies with the following standards: EN 61000-6-2; EN 61000-6-3*

Oderzo, 20 Ottobre 2005

  
Amministratore delegato  
(General Manager)  
Lauro Buoro



 **Nice SpA**  
Oderzo TV Italia  
Tel. +39.0422.85.38.38  
Fax +39.0422.85.35.85  
info@niceforyou.com

 **Nice Padova**  
Sarameola di Rubano PD Italia  
Tel. +39.049.89.78.93.2  
Fax +39.049.89.73.85.2  
infopd@niceforyou.com

 **Nice Roma**  
Roma Italia  
Tel. +39.06.72.67.17.61  
Fax +39.06.72.67.55.20  
inforoma@niceforyou.com

 **Nice France**  
Buchelay  
Tel. +33.(0)1.30.33.95.95  
Fax +33.(0)1.30.33.95.96  
info@fr.niceforyou.com

 **Nice Rhône-Alpes**  
Decines Charpieu France  
Tel. +33.(0)4.78.26.56.53  
Fax +33.(0)4.78.26.57.53  
info@lyon@fr.niceforyou.com

 **Nice France Sud**  
Aubagne France  
Tel. +33.(0)4.42.62.42.52  
Fax +33.(0)4.42.62.42.50  
infomarseille@fr.niceforyou.com

 **Nice Belgium**  
Leuven (Heverlee)  
Tel. +32.(0)16.38.69.00  
Fax +32.(0)16.38.69.01  
info@be.niceforyou.com

 **Nice Romania**  
Cluj Napoca  
info@ro.niceforyou.com

 **Nice Deutschland**  
Frankfurt  
info@de.niceforyou.com

 **Nice España Madrid**  
Tel. +34.9.16.16.33.00  
Fax +34.9.16.16.30.10  
info@es.niceforyou.com

 **Nice España Barcelona**  
Tel. +34.9.35.88.34.32  
Fax +34.9.35.88.42.49  
info@es.niceforyou.com

 **Nice Polska**  
Pruszków  
Tel. +48.22.728.33.22  
Fax +48.22.728.25.10  
info@pl.niceforyou.com

 **Nice UK**  
Chesterfield  
Tel. +44.87.07.55.30.10  
Fax +44.87.07.55.30.11  
info@uk.niceforyou.com

 **Nice China**  
Shanghai  
Tel. +86.21.575.701.46  
+86.21.575.701.45  
Fax +86.21.575.701.44  
info@cn.niceforyou.com

COMPANY  
WITH QUALITY SYSTEM  
CERTIFIED BY DNV  
=ISO 9001/2000=

 **Nice Gate** is the doors and gate automation division of Nice

 **Nice Screen** is the rolling shutters and awnings automation division of Nice

[www.niceforyou.com](http://www.niceforyou.com)





**Installation and use instructions  
and warnings**

**Istruzioni ed avvertenze per  
l'installazione e l'uso**

**Instructions et avertissements pour  
l'installation et l'utilisation**

**Anweisungen und Hinweise für die  
Installation und die Bedienung**

**Instrucciones y advertencias para  
la instalación y el uso**

**Instrukcje i ostrzeżenia związane z  
instalowaniem i użytkowaniem**

**Aanwijzingen en aanbevelingen  
voor installering en gebruik**

**Nice**

# NiceOne

**Receiver**

OXI family  
OX2 family

Europe: **CE 0682**

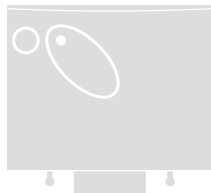

- EN** – Models with “SM” type connection
- IT** – Modelli con connessione a innesto “SM”
- FR** – Modèles avec connecteur embrochable «SM»
- ES** – Modelos con conexión con conector “SM”
- DE** – Modelle mit Steckverbindung “SM”
- PL** – Modele z połączeniem za pomocą złącza typu “SM”
- NL** – Modellen met steekconnector “SM”



- EN** – Models with universal type connection
- IT** – Modelli con connessione universale
- FR** – Modèles avec connecteur universel
- ES** – Modelos con conexión universal
- DE** – Modelle mit Universalverbindung
- PL** – Modele z połączeniem uniwersalnym
- NL** – Modellen met universele aansluiting



## 1 – PRODUCT DESCRIPTION AND INTENDED USE

This receiver is part of the series “NiceOne” produced by Nice spa. The receivers in this series are destined for use on the control units fitted on systems for the automation of gates, garage doors and road barriers. **Any use other than as specified herein is to be considered improper and is strictly prohibited!** The manufacturer denies all liability for damage deriving from improper use of the product and use other than as specified in this manual.

Various models are available, with the specifications as stated in the table below.



### 1.1 – The “NiceOpera” system

The receivers in the series **NiceOne** are part of the “NiceOpera” system. This system has been designed to simplify the programming phases, use and maintenance of the devices normally used in automation systems. The system com-

prises various software and hardware devices capable of intercommunicating via radio, by means of the “O-Code” encoding system or a “physical” connection via cable. The main devices that make up the NiceOpera system are:

- NiceOne transmitters;
- NiceOne receivers;
- O-box programming unit;
- Control units and gearmotors with “T4 Bus”;
- O-View programmer for devices with “T4 Bus”.

**IMPORTANT** – For further details on all functions of the NiceOpera system and interdependency of the various devices in the system, refer to the general manual “NiceOpera System Book”, also available on the Internet site [www.niceforyou.com](http://www.niceforyou.com).

	Mod.	Frequency	Function	Connection
	OXI	433.92 MHz	Receiver	Connector type
	OXIFM	868.46 MHz	Receiver	Connector type
	OXIT	433.92 MHz	Receiver-transmitter	Connector type
	OXITFM	868.46 MHz	Receiver-transmitter	Connector type
	OX2	433.92 MHz	Receiver	with 6-core cable
	OX2FM	868.46 MHz	Receiver	with 6-core cable
	OX2T	433.92 MHz	Receiver-transmitter	with 6-core cable
	OX2TFM	868.46 MHz	Receiver-transmitter	with 6-core cable

#### Notes to table:

– The frequencies 433.92 MHz and 868.46 MHz are not compatible.

– The letter “T” in the model name indicates a receiver with built-in transmitter.

## 2 – FUNCTIONAL PRODUCT SPECIFICATIONS

### • For all models

- The receiver manages “O-Code” radio encoding with variable code (*rolling-code*), which enables use of all the new functions in the NiceOpera system.

The receiver is compatible also with “FloR”, “TTS”, “Smilo” and “Flo” encoding systems. However, in this case **some of the exclusive NiceOpera system functions described in this manual cannot be used.**

- The receiver has a capacity of 1024 spaces in which to memorise transmitters. If the transmitter is memorised in “Mode I”, all the relative keys will occupy 1 memory allocation; otherwise if memorised in “Mode II”, each memorised key will occupy 1 memory allocation (*for memorisation procedures, see below in this manual*).
- Each receiver has its own identification number called a “Certificate”.

This number enables access to a series of operations, such as: Memorisation of new transmitters without the need for direct intervention on the receiver and use of the O-View unit, by means of the “T4 Bus” connection.

The sealed coupon in the product pack contains the sheet with the certificate number of this receiver. **Caution!** – *this coupon must be kept in a safe place as it enables access to data stored in the receiver, unless further protection measures are adopted, such as the use of a security password.*

### • For models with “SM” type connection

- These models can be used exclusively with the control units fitted with an “SM” type connection (**fig. 1**). **Note** – *to identify compatible control units, refer to the Nice product catalogue.*
- These models automatically recognise the characteristics of the control unit to which they are connected and the receiver self-installs as follows.
  - **If the control unit manages the “T4 Bus”**, the receiver provides up to 15 different commands.
  - **If the control unit does not manage the “T4 Bus”**, the receiver provides up to 4 different command channels.**Caution!** – *In both cases the number and variety of the commands available depend on the type and model of control unit used. The “Table of commands” of each control unit is provided in the instruction manual of the relative control unit.*

### • For models with universal type connection

- These models operate with 2 voltage-free contact relays and therefore can be used with any type of control unit.

### • For models with “T” in the model name

- These models are equipped with a “Repeater” function (*see below in this manual*) which enables an increase in the transmission range of the transmitters. They also enable “wireless” communication with the O-Box programming unit.

### 3 – PRODUCT INSTALLATION

#### • For models with “SM” type connection

These models are connected to the control unit by inserting the connector in the relative control unit connector (fig. 1).

**Caution!** – Before connecting or removing the receiver, disconnect the control unit from the power supply.

The aerial supplied must also be installed, connecting it to the specific terminals on the control unit.

#### • For models with universal type connection

##### — Power supply selection —

These models are connected to the control unit by means of a 6-core cable. Before connecting the cable, select the type of power supply required, leaving or removing the electric jumper as necessary (fig. 2-a) as follows:

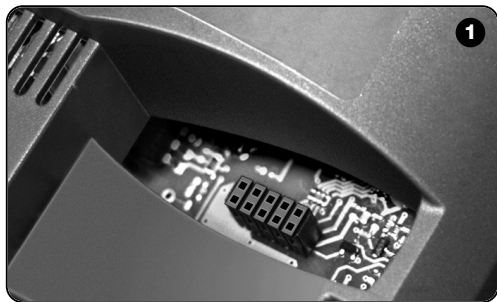

– **Jumper NOT inserted** = 24 V ac/dc  
(voltage limits: 18 ÷ 28 V)

– **Jumper INSERTED** = 12 V ac/dc  
(voltage limits: 10 ÷ 18 V)

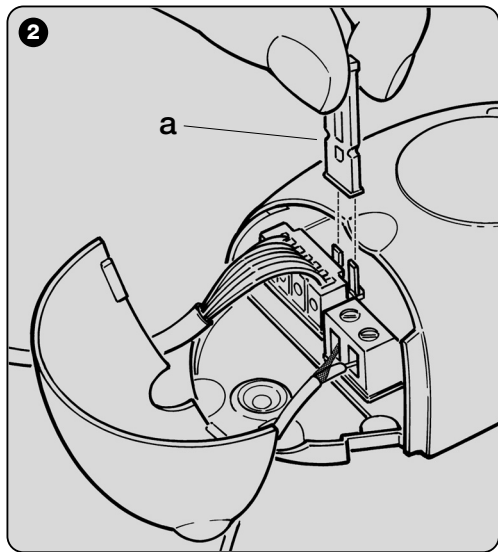

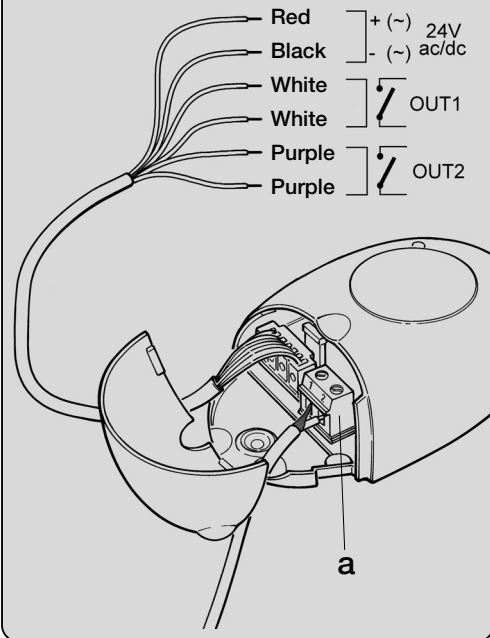

### — Electrical connections —

Connect the 6 wires of the receiver cable to the relative terminals of the control unit as follows (**fig. 3**):

- **Red** and **Black** = **POWER SUPPLY**  
 (red = *Positive*, black = *Negative*. In AC this is not important).
- **White** and **White** = **RELAY 1 OUTPUT**  
 (voltage-free contact of a normally open relay).
- **Purple** and **Purple** = **RELAY 2 OUTPUT**  
 (voltage-free contact of a normally open relay).

### — How to obtain “NC” type contacts —

The outputs are controlled by 2 relays with NO (normally open) type contact. To change to NC (normally closed) type contact, proceed as follows:

- 01.** Disconnect the receiver from the power supply.
- 02.** Open the box of the receiver by first raising the smaller section of the cover (**fig. 4-a**) and then the larger section with the key (**fig. 4-b**).
- 03.** Carefully remove the board and turn it over: *the side with the soldered elements must be facing the user*.
- 04.** On the side with the soldered elements, proceed as follows (**fig. 5**):
  - Cut the traced section at point “**X**”
  - Join the contacts with a drop of tin at points “**Y**”.

**Note** – *these modifications may be applied to one or both relays as required.*

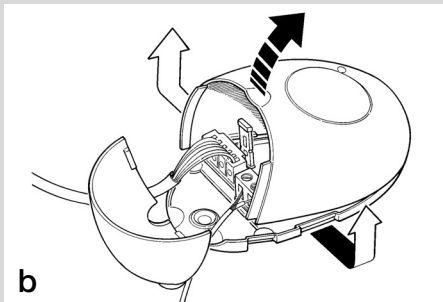
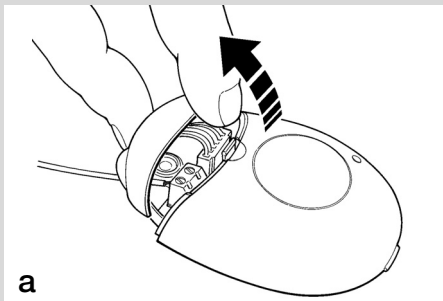
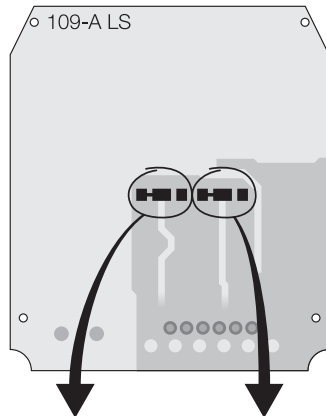
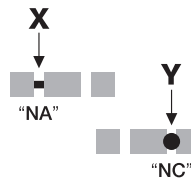
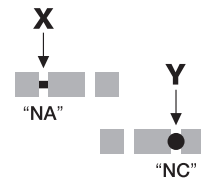
**4****5****RELÈ n° 2****RELÈ n° 1**



• **For all models:**  
**Installation of an external aerial**

If the aerial supplied is in an unfavourable position and the radio signal is weak, an external aerial may be installed to improve reception (mod. ABF or ABFKIT). The new aerial must be positioned as high as possible and above any metal or reinforced concrete structures present in the area.

- **Connection to the Control Unit:** Use a coaxial cable with an impedance of 50 ohm (for example, a RG58 cable with low loss). **Caution!** – *To reduce signal dispersion use a cable that is as short as possible (not exceeding 10 m).*
- **Connection to the receiver (only for models with universal type connection):** Open the receiver by first raising the smaller section of the cover (fig. 4-a) and disconnect the aerial supplied; then connect the cable of the new aerial to terminal **1** and **2** as follows (fig. 3-a): **Terminal 1** = sheath; **Terminal 2** = core.

## PROGRAMMING THE MAIN FUNCTIONS

### Programming warnings

*The settings described in this chapter (except for procedure 6) require use of the key and led on the receiver (fig. 6). To indicate the state of activity in progress, the led emits a set number of flashes with a specific duration and colour (green, red or orange). For the meaning of these signals, refer to **Table A** at the end of the manual.*

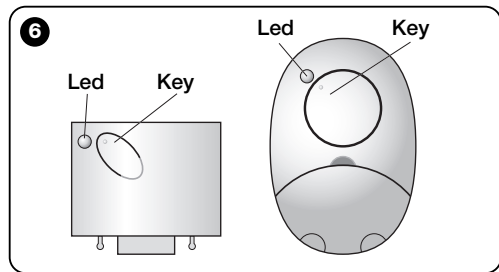

## 4 – CAUTION! – READ THIS SECTION BEFORE MEMORISING THE TRANSMITTER

The receiver can only memorise transmitters belonging to one of the following 3 encoding families:

- family with “**O-Code**”, “**FloR**” and “**TTS**” encoding;
- family with “**Flo**” encoding;
- family with “**Smilo**” encoding.

**Note** – Each code enables use *exclusively* of the standard associated functions on the receiver.

**Caution!** – The encoding family of the **first** transmitter memorised on the receiver also defines the relative encoding family for the subsequent transmitters to be memorised.

To change the encoding family set on the receiver, perform procedure 10 – Total receiver memory deletion.

To check on the receiver whether transmitters and the associated encoding family are already memorised, proceed as follows:

- 01.** Disconnect the receiver from the power supply.
- 02.** Re-connect the power to the receiver and count the number of **green** flashes emitted by the receiver led.
- 03.** Check the number of flashes emitted with the data in the table below:
  - 1 flash = **Flo** encoding
  - 2 flashes = **O-Code** / **FloR** / **TTS** encoding
  - 3 flashes = **Smilo** encoding
  - 5 flashes = no transmitter entered

**Caution!** – Before memorising a transmitter, carefully read all memorisation procedures described below to select the one most suited to your specific application.

## 5 – TRANSMITTER MEMORISATION PROCEDURE: “Mode I” AND “Mode II”

Each control unit has a set number of commands that can be activated according to the type of receiver: The models with “**SM**” connector provide 4 or 15 commands while models with the **universal connection** provide 2 outputs.

In general the commands can be associated with the transmitter keys in two ways:

- “**Mode I**”. This mode enables memorisation on the receiver of all transmitter keys or a group of the latter at once (on transmitters with more than one identity code such as model ON9). The keys are automatically associated with the pre-set commands of the control unit or the receiver outputs, on models with universal connection.
- “**Mode II**”. This mode enables memorisation on the receiver of a single transmitter key. The user has a free choice of which command, among those available on the control unit (maximum 4) or which output of the receiver to be associated with the selected key.
  - “**Extended Mode II**” (only for models with “SM” connector). This mode can only be used with control units using the connection system “T4 Bus”. The “Extended Mode II” is the same as “**Mode II**” with the additional option to choose the required command from those available in the “*Table of commands*” (maximum 15), as provided in the manual of the control unit connected to the receiver.

### 5.1 – Memorisation in “MODE I”

**Warning** – This procedure *simultaneously memorises all keys of the transmitter or a group of the latter (on transmitters with more than one identity code).*

01. Press and hold the key on the receiver until the **green** led on the receiver illuminates. Then release the key.
02. (within 10 seconds) On the transmitter to be memorised, press and hold any key until the led on the receiver emits the first of 3 **green** flashes to confirm memorisation.

**Note** – After the three flashes, a 10-second interval is available to memorise another transmitter as required.

### 5.2 – Memorisation in “MODE II” (valid also for “Extended Mode II”)

#### WARNINGS:

- The “Extended Mode II” procedure can only be used with receivers with “SM” type connectors.
- This procedure enables memorisation of a single transmitter key.

01. In the control unit manual, look up the “Table of commands”, select the command to assign to the transmitter key and note the **number** corresponding to the command.
02. (on the receiver) Press the key the same number of times as the previously noted **number** – the Led on the receiver emits the same number of flashes repeated at regular intervals.
03. (on the transmitter within 10 seconds) Press and hold the selected key for memorisation until the led on the receiver emits the first of 3 flashes (= memorisation confirmed).

**Note** – After the three flashes, a 10-second interval is available to memorise the same command on other keys on the same transmitter or a new transmitter as required.

## 6 – MEMORISING A TRANSMITTER USING THE “ENABLE CODE” OF ANOTHER TRANSMITTER [already memorised]

This procedure can only be used if two transmitters with “O-Code” encoding are used.

The NiceOne transmitters have a secret code stored in the memory, known as the “ENABLE CODE”. Thanks to this code, operation of NEW transmitter can be enabled by simply transferring the “enable code” of an OLD transmitter (previously memorised on the receiver) onto its memory (**fig. 8**).

**Note** – For this procedure, refer to the transmitter manual. Subsequently, when the NEW transmitter is used, it will transmit its own identity code to the receiver as well as the relative “enable code” (the first twenty times only). The receiver, after recognising the “enable code” of an OLD transmitter (previously memorised on the receiver) automatically memorises the identity code of the NEW transmitter sent to it.

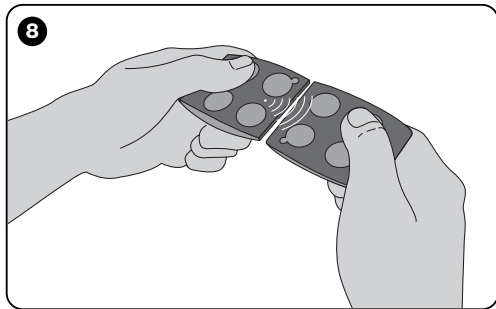

- **Preventing accidental use of this memorisation procedure**

To prevent memorisation on the receiver of other transmitters not compatible with the system but with the “enable code” of a transmitter already memorised on the receiver, this procedure can be “locked” (or unlocked) by programming the function in **paragraph 10**.

As an alternative to locking memorisation of the entire receiver, transfer of the “enable code” can be disabled exclusively for some or all OLD transmitters already memorised. This operation can be performed using the O-Box programming unit.

## **7 – MEMORISATION OF A TRANSMITTER USING THE PROCEDURE IN THE VICINITY OF THE RECEIVER**

**[with a transmitter already memorised]**

A NEW transmitter can be memorised in the receiver memory without acting directly on the key of the receiver, but by simply working within its reception range. To use this procedure, an OLD transmitter, previously memorised (in “Mode I” or in “Mode II”) and operative, is required. The procedure enables the NEW transmitter to receive the settings of the OLD version.

### **WARNINGS:**

- ***Use only one of the two procedures described below, according to requirements.***
- ***The procedure must be performed within the reception range of the receiver (maximum 10-20 m from receiver).***
- ***Repeat the same procedure for each transmitter to be memorised.***

### **Standard Procedure (valid for all Nice receivers)**

- 01.** On the NEW transmitter, press and hold the key.... for at least 5 seconds (see **note 1**) and then release.
- 02.** On the OLD transmitter, press key.... three times (see **note 1**) and then release.
- 03.** On the NEW transmitter, press the same key pressed in point 01 once and then release.

### **Alternative Procedure (valid for this receiver only)**

- 01.** On the NEW transmitter, press and hold the key.... for at least 3 seconds (see **note 1**) and then release.
- 02.** On the OLD transmitter, press and hold the key.... for at least 3 seconds see **note 1**) and then release.

- 03.** On the NEW transmitter, press the same key pressed in point 01 for at least 3 seconds and then release.
- 04.** On the OLD transmitter, press the same key pressed in point 02 for at least 3 seconds and then release.

**Note 1:**

If the OLD transmitter is memorised in "Mode I" the NEW transmitter will also be memorised in "Mode I". In this case, during the procedure press any key on either the OLD or NEW transmitter.

If the OLD transmitter is memorised in "Mode II" the NEW transmitter will also be memorised in "Mode II". In this case, during the procedure press the required command key on the OLD transmitter and the associated key to be memorised for this command on the NEW transmitter. This procedure must also be repeated for each key of the NEW transmitter to be memorised.

• **Preventing accidental use of this memorisation procedure**

To prevent the continuous reception of a signal transmitted at random by a transmitter not part of the system from accidentally activating the memorisation procedure, this procedure can be "locked" (or unlocked) by programming the function in **paragraph 10**.

## 8 – TOTAL RECEIVER MEMORY DELETION

All transmitters memorised can be deleted from the receiver memory, or all data present in the latter can be deleted as follows:

- 01.** Press and hold the receiver key and check the following changes in Led status:
- (after approx. 4 seconds) the **green** led illuminates;
  - (after approx. 4 seconds) the **green** led turns off;
  - (after approx. 4 seconds) the **green** led starts flashing.
- 02.** At this point release the key exactly.....
- **on the 3rd flash**, to delete all transmitters, or,
  - **on the 5th flash**, to delete the entire memory of the receiver, including configurations and encoding families of the transmitters.

Alternatively this function can be performed using the O-Box or O-View programming unit.

## 9 – DELETING A SINGLE TRANSMITTER FROM THE RECEIVER MEMORY

A single transmitter (in your possession) memorised can be deleted from the receiver memory as follows:

- 01.** Press and hold the receiver key.
- 02.** After approx. 4 seconds the **green** led illuminates (*keep the key pressed*).
- 03.** On the transmitter to be deleted from the memory, press and hold any key (see **note 1**) until the led on the receiver emits 5 **green** flashes (= *deletion confirmed*).

**Note 1:**

If the transmitter is memorised in **"Mode I"** any key can be pressed.

If the transmitter is memorised in **"Mode II"** the entire procedure must be repeated for each memorised key to be deleted.

Alternatively this function can be performed using the O-Box or O-View programming unit.

## 10 – ENABLING (or disabling) THE RECEIVER FOR TRANSMITTER MEMORISATION

This function enables the user to prevent memorisation of new transmitters when the procedures **"in the vicinity"** (factory setting is **ON**) or with **"enable code"** (factory setting is **ON**) are used as described in this manual. To enable or disable this function, proceed as follows:

01. Disconnect the receiver from the power supply and wait 5 seconds.
02. Reconnect the power and switch on by pressing the receiver key until the relative led has completed the signals indicating the type of code stored in the memory (see paragraph 5) and the procedure is activated, indicated by 2 short **orange** flashes. Then release the key.
03. (within 5 seconds) Press the receiver key repeatedly to select one of the following functions (**Warning!** – on each press of the key the Led changes colour to indicate the currently selected function):
  - Led **OFF** = No lock enabled
  - Led **RED** = Memorisation "in the vicinity" locked
  - Led **GREEN** = Memorisation with "enable code" locked

- Led **ORANGE** = Both memorisation modes locked ("in the vicinity" and with "enable code").

04. (within 5 seconds) Press any key of a transmitter already memorised on the receiver to save the selected function.

Alternatively the lock (or unlock) function can be applied using the O-Box or O-View programming unit.

## OTHER FUNCTIONS

**WARNING** – *The settings described in this chapter require use of the O-Box or O-View programming unit. For operation of these devices, refer to the relative instruction manuals, also available on the internet site: [www.niceforyou.com](http://www.niceforyou.com).*

- *The models with “SM” connector are connected to the O-Box unit by inserting the receiver in the relative connector.*
- *The models with universal connector are connected to the O-Box unit by means of a special cable (fig. 7-a) which must be connected to the connector on the receiver (see fig. 7-b).*

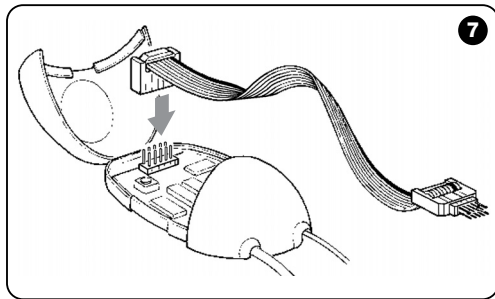

## 11 – MEMORISATION OF A TRANSMITTER USING THE RECEIVER “CERTIFICATE NUMBER”

**[with O-Box]** – This procedure can only be used if a transmitter is used with “O-Code” encoding and when in possession of the receiver “Certificate Number”.

The “**CERTIFICATE**” is a personal number (factory set) identifying the single receiver to distinguish it from all others.

Use of this “certificate” simplifies the procedure required to memorise the transmitter in the receiver, as it no longer obliges the installer to work within the receiver operating range. In fact the new procedure enables transmitter memorisation from any distance, even far from the installation site (for example from the installer’s office – fig. 9).

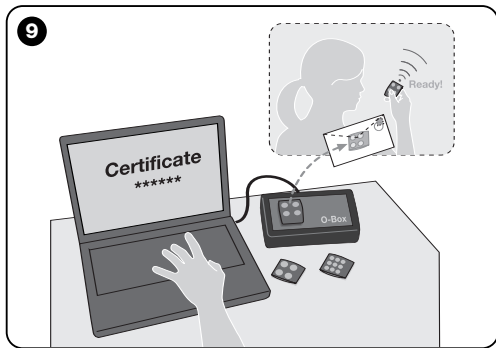

Initially, the procedure consists in the installer entering, with the aid of the programming unit “O-Box”, the required functions and the relative receiver “certificate” in the memory of the transmitter. The transmitter, ready to use, is then sent to the client.

Subsequently, when the transmitter is used, it will transmit the command along with the “certificate” to the receiver (*the first twenty times only*). The receiver, after recognising the “certificate” as its own, automatically memorises the identity code of the transmitter that sent the certificate.

## 12 – REMOTE REPLACEMENT OF A TRANSMITTER USING “PRIORITY” MODE

**[with O-Box]** – The identity code of a transmitter in the NiceOne series is accompanied by a **number** (from **0** to **3**), which enables the user to specify the transmitter’s **priority level** on a receiver with respect to any other transmitters with the same code.

This “**priority**” serves to replace, and thus disable, use of a transmitter that has been lost or stolen, without the need to return to the client’s system.

Use of priority mode requires knowledge of the code of the lost transmitter and enables maintenance of the same code and functions of the previous transmitter.

Therefore the lost transmitter can be disabled by simply updating the priority level of the new transmitter with the next highest value.

On first use of the transmitter, the receiver memorises the **new priority level** received and ignores any command sent by the lost or stolen transmitter if subsequently used.

This function can be enabled (or disabled) on the receiver (*factory setting ON*) and, when active, the receiver does not update the priority level sent by the transmitter.

## 13 – ENABLING (or disabling) RECEPTION OF NON-ORIGINAL “IDENTITY CODES”

**[with O-Box / O-View]** – The identity codes of transmitters with “FloR” and “O-Code” encoding can be modified as required, using the “O-Box” or “O-View” programming unit. The receiver can normally recognise whether a code is original (factory set) or modified.

When this function is enabled or disabled (*factory setting ON*) the receiver has the option to accept (or not) the command of a transmitter with a modified *identity code*.

## 14 – LOCKING (or unlocking) THE MOBILE SECTION (*Rolling code*) OF THE IDENTITY CODE

**[with O-Box / O-View]** – This function enables the user to lock (or unlock) management on the receiver of the variable section (*rolling code*) of an identity code sent by a transmitter. When the lock function is active (*factory setting OFF*), the receiver treats a “rolling code” as if it were a “fixed” code, ignoring the variable section.



## 15 – ENABLING (or disabling) THE “REPEATER” FUNCTION

(Function available only on models OXIT, OXITFM, OX2T, OX2TFM, in combination with transmitters using O-Code encoding).

**[with O-Box]** – If an automation is to be controlled at a distance greater than that normally covered by the transmitter and receiver, a second receiver may be used (up to a maximum of five) serving to re-transmit, via radio, the command to the final receiver (in which the sending transmitter identity code is memorised), so that this can execute the command. To enable or disable this function (*factory setting OFF*) programming must be performed both on the additional receivers and transmitters.

## 16 – MANAGING RELEASE OF THE TRANSMITTER KEYS

(Function available only on transmitters using O-Code encoding)

**[with O-Box / O-View]** – Normally, after sending a command, on release of the key the manoeuvre is not stopped immediately but proceeds for a very short pre-set interval. If necessary, the manoeuvre can be interrupted at the exact time of key release (required for example during minimal adjustments) by enabling this function (*factory setting OFF*).

## 17 – ENABLING (or disabling) COMMAND DELIVERY ON THE “T4 BUS” NETWORK

**[with O- View]** – On systems in which connection is via the “T4 Bus”, if more than one receiver is installed, and there is the need for control at a distance greater than that normally covered by the transmitter and receiver, this function can be enabled (on at least 2 receivers) to increase the receiver reception range.

This enables the receiver that receives a command “via radio” to re-transmit the command via the Bus cable to the final receiver (in which the sending transmitter identity code is memorised), so that this can execute the command.

To enable or disable the option to receiver and/or send radio codes on the “T4 Bus” in a receiver (*factory setting OFF*), the receivers concerned must be duly programmed, using the O-View programming unit.

## 18 – CREATING THE “FAMILY GROUPS” OF TRANSMITTERS

**[with O-Box]** – Each code memorised on the receiver can be associated with one or more “family groups”, from the 4 available.

The formation of groups and their activation or deactivation (*factory setting OFF*) is managed by means of the O-Box programming unit while use of the groups, for example in a set time-band, is managed by means of the O-View programming unit.

## 19 – PROTECTION OF PROGRAMMED FUNCTION SETTINGS

**[with O-Box / O-View]** – This function enables the user to protect all programmed functions on the receiver, also disabling functionality of the key and relative led. The function is enabled by entering a **password** on the receiver, i.e. a maximum of 10 digits, as set by the installer.

When the function is enabled, before programming and maintenance of the receiver, the special *password* must be entered on the programming unit to unlock the receiver.

## DISPOSAL OF THE PRODUCT

**This product constitutes an integral part of the automation system, therefore it must be disposed of along with it.**

As in installation, also at the end of product lifetime, the disassembly and scrapping operations must be performed by qualified personnel.

This product is made up of different types of material, some of which can be recycled while others must be disposed of. Seek information on the recycling and disposal systems envisaged by the local regulations in your area for this product category.

**Caution!** – some parts of the product may contain pollutant or hazardous substances which, if disposed of into the environment, may cause serious damage to the environment or physical health.

As indicated by the symbol on the left, disposal of this product in domestic waste is strictly prohibited. Separate the waste into categories for disposal, according to the methods envisaged by current legislation in your area, or return the product to the retailer when purchasing a new version.



**Caution!** – Local legislation may envisage serious fines in the event of abusive disposal of this product.

## PRODUCT TECHNICAL SPECIFICATIONS

	OXI	OXIT	OXIFM	OXITFM
• Decoding	"O-Code" / "FloR" / "TTS"; or "Flo"; or "Smilo"			
• Maximum absorption	30 mA			
• Reception frequency	433.92 MHz		868.46 MHz	
• Transmission frequency	—	433.92 MHz	—	868.46 MHz
• Sensitivity	Above 0.5 $\mu$ V		Above 0.8 $\mu$ V	
• Operating temperature	-20° C ÷ +55° C			
• Outputs	4 (on "SM" connector)			
• Dimensions and weight	L. 50; H. 45; P. 19 mm; weight 20			
• Radiated power	—	approx. 1 mW E.R.P.	—	approx. 1 mW E.R.P.
• Input impedance	52 ohm			
	OX2	OX2T	OX2FM	OX2TFM
• Decoding	"O-Code" / "FloR" / "TTS"; or "Flo"; or "Smilo"			
• Power supply	Without electric jumper = 24 V standard. <b>Limits from 18 to 28 V direct or alternating</b> With electric jumper = 12 V standard. <b>Limits from 10 to 18 V direct or alternating</b>			
• Absorption on standby	10 mA at 24 Vac			
• Absorption with 2 relays activ	80 mA at 24 Vac.			
• Reception frequency	433.92 MHz		868.46 MHz	
• Transmission frequency	—	433.92 MHz	—	868.46 MHz
• Sensitivity	Above 0.5 $\mu$ V		Above 0.8 $\mu$ V	
• N° relays	2			
• Relay contact	Normally open max 0,5 A and 50 V			
• Operating temperature	-20° C ÷ +55° C			
• Protection rating	IP 30			
• Dimensions and weight	58 x 86; H. 22 mm; weight 55 g			
• Radiated power	—	approx. 1 mW E.R.P.	—	approx. 1 mW E.R.P.

*As well as the functions and settings described in this manual, the receiver offers many other features to enhance performance, safety and ease of use.*

*All these settings require use of the O-Box (or in some cases O-View) programming unit.*

*For further information on the settings available, refer to the general system manual "NiceOpera System Book", or the O-Box/ O-View programming unit manual.*

### • **Notes on Product Technical specifications**

- *The range of the transmitters and reception capacity of the receivers is strongly influenced by other devices (for example: alarms, radio headphones etc.) operating in the zone at the same frequency. In these cases, Nice cannot guarantee the effective capacity of its devices.*
- *All technical specifications stated in this section refer to an ambient temperature of 20°C (± 5°C).*
- *Nice reserves the right to apply modifications to the product at any time when deemed necessary, while maintaining the same functionalities and intended use.*

**Table A****SIGNALS EMITTED BY THE RECEIVER LED**— **Long flashes / GREEN** —*On start-up:*

- 1 \* = Code in use: "Flo"
- 2 \* = Code in use: "O-Code"/"FloR"
- 3 \* = Code in use: "Smilo"
- 5 \* = No remote control memorised

*During operation:*

- 1 \* = Indicates that the code received is not stored in the memory
- 1 \* = During programming, indicates that the code is already stored in the memory
- 3 \* = Saving code in memory
- 5 \* = Memory deleted
- 6 \* = During programming, indicates that the code is not authorised for memorisation
- 8 \* = Memory full

— **Short flashes / GREEN** —

- 1 \* = "Certificate" not valid for memorisation
- 2 \* = Code cannot be memorised as is transmitting "certificate"
- 3 \* = During programming, indicates that the code has

been re-synchronised

- 4 \* = Output in "Mode II" not managed on control unit
- 5 \* = During deletion procedure, indicates that the code has been deleted
- 5 \* = "Certificate" with higher priority than the admissible value
- 6 \* = Code synchronisation failure
- 6 \* = Code cannot be memorised due to "incorrect key"

— **Long flashes / RED** —

- 1 \* = Non-original code block
- 2 \* = Code with lower priority than the authorised value

— **Short flashes / RED** —

- 1 \* = "In vicinity" programming mode block
- 1 \* = Memorisation by means of "certificate" block
- 2 \* = Memory block (PIN entry)

— **Long flashes / ORANGE** —

- 1 \* = Indicates that the code is in the memory but outside the group currently enabled

— **Short flashes / ORANGE** —

- 2 \* = Indicates activation of block programming (on start-up)

## EC DECLARATION OF CONFORMITY

**Note** – This Declaration of Conformity contains the individual declarations of conformity for the specified products; it was updated on the issue date of this manual and the text herein has been drawn up for editorial purposes. A copy of the original declaration for each product can be requested from Nice S.p.a. (TV) I.

The undersigned, Lauro Buoro, in the role of Managing Director, declares under his sole responsibility, that the product:

**Manufacturer's name :** Nice S.p.a.

**Address:** Via Pezza Alta 13, Z.I. Rustignè, 31046 Oderzo (TV) Italy

**Type:** Receiver and receiver-transmitter for remote control of automations for doors, gates, shutters, awnings, rolling shutters and similar applications.

**Models:** OXI, OXIT, OXIFM, OXITFM

**Accessories:**

conform with the requirements of the EC directive:

- 1999/5/EC; DIRECTIVE 1999/5/EC OF THE EUROPEAN PARLIAMENT AND COUNCIL of 9 March 1999 regarding radio equipment and telecommunications terminal equipment and the mutual recognition of their conformity

According to the following harmonised standards

Health protection: EN 50371:2002;

Electrical safety: EN 60950-1:2006;

Electromagnetic compatibility : EN 301 489-1V1.6.1:2006; EN 301 489-3V1.4.1:2002

Radio range: EN 300220-2V2.1.2:2007

**Lauro Buoro**  
(Managing director)



## EC DECLARATION OF CONFORMITY

**Note** – This Declaration of Conformity contains the individual declarations of conformity for the specified products; it was updated on the issue date of this manual and the text herein has been drawn up for editorial purposes. A copy of the original declaration for each product can be requested from Nice S.p.a. (TV) I.

The undersigned, Lauro Buoro, in the role of Managing Director, declares under his sole responsibility, that the product:

**Manufacturer's name** : Nice S.p.a.

**Address**: Via Pezza Alta 13, Z.I. Rustignè, 31046 Oderzo (TV) Italy

**Type**: Receiver and receiver-transmitter for remote control of automations for doors, gates, shutters, awnings, rolling shutters and similar applications.

**Models**: OX2, OX2T, OX2FM, OX2TFM

**Accessories**:

conform with the requirements of the EC directive:

- 1999/5/EC; DIRECTIVE 1999/5/EC OF THE EUROPEAN PARLIAMENT AND COUNCIL of 9 March 1999 regarding radio equipment and telecommunications terminal equipment and the mutual recognition of their conformity

According to the following harmonised standards

Health protection: EN 50371:2002;

Electrical safety: EN 60950-1:2006;

Electromagnetic compatibility : EN 301 489-1V1.6.1:2006; EN 301 489-3V1.4.1:2002

Radio range: EN 300220-2V2.1.2:2007

**Lauro Buoro**  
(Managing director)



Nice

#### Headquarters

##### Nice SpA

Oderzo TV Italia  
Ph. +39.0422.85.38.38  
Fax +39.0422.85.35.85  
info@niceforyou.com

##### Nice in Italy

##### Nice Padova

Sarmeola di Rubano PD Italia  
Ph. +39.049.89.78.93.2  
Fax +39.049.89.73.85.2  
infopd@niceforyou.com

##### Nice Roma

Roma RM Italia  
Ph. +39.06.72.67.17.61  
Fax +39.06.72.67.55.20  
inforoma@niceforyou.com

#### Nice Worldwide

##### Nice France

Buchelay France  
Ph. +33.(0)1.30.33.95.95  
Fax +33.(0)1.30.33.95.96  
info@fr.niceforyou.com

##### Nice France Sud

Aubagne France  
Ph. +33.(0)4.42.62.42.52  
Fax. +33.(0)4.42.62.42.50  
infomarseille@fr.niceforyou.com

##### Nice France Rhône Alpes

Decines Charpieu France  
Ph. +33.(0)4.78.26.56.53  
Fax +33.(0)4.78.26.57.53  
infoyon@fr.niceforyou.com

##### Nice Belgium

Leuven (Heverlee) Belgium  
Ph. +32.(0)16.38.69.00  
Fax +32.(0)16.38.69.01  
info@be.niceforyou.com

##### Nice Deutschland

Gelnhausen Deutschland  
Ph. +49.(0)6051.91.520  
Fax +49.(0)6051.91.52.119  
info@de.niceforyou.com

#### Nice España Madrid

Mostoles Madrid España  
Ph. +34.(0)9.16.16.33.00  
Fax +34.(0)9.16.16.30.10  
info@es.niceforyou.com

#### Nice España Barcelona

Sant Quirze del Valles  
Barcelona España  
Ph. +34.(0)9.37.84.77.75  
Fax +34.(0)9.37.84.77.72  
info@es.niceforyou.com

#### Nice Polska

Pruszków Polska  
Ph. +48.(0)22.759.40.00  
Fax +48.(0)22.759.40.22  
info@pl.niceforyou.com

#### Nice Portugal

Mem Martins Portugal  
Ph. +351.21.922.82.10  
Fax +351.21.922.82.19  
info@pt.niceforyou.com

#### Nice Romania

Cluj Napoca Romania  
Ph./Fax +40.(0)264.453.127  
info@ro.niceforyou.com

#### Nice Turkey

Kadikoy Istanbul Turkey  
Ph. +90.216.456.34.97  
Fax +90.216.455.78.29  
info@tr.niceforyou.com

#### Nice UK

Sutton in Ashfield  
United Kingdom  
Ph. +44.16.23.55.80.86  
Fax +44.16.23.55.05.49  
info@uk.niceforyou.com

#### Nice Australia

Wetherill Park Australia  
Ph. +61.(0)2.96.04.25.70  
Fax +61.(0)2.96.04.25.73  
info@au.niceforyou.com

#### Nice China

Shanghai P. R. China  
Ph. +86.21.575.701.46/45  
Fax +86.21.575.701.44  
info@cn.niceforyou.com

#### Nice USA

Jacksonville Florida USA  
Ph. +1.904.786.7133  
Fax +1.904.786.7640  
info@us.niceforyou.com