

# FT210

Optical Device

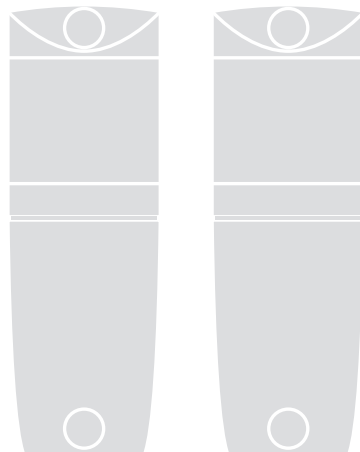

**Installation instructions and warnings**  
**Istruzioni ed avvertenze per l'installatore**  
**Instructions et avertissements pour l'installateur**  
**Anweisungen und Hinweise für den Installateur**  
**Instrucciones y advertencias para el instalador**  
**Aanwijzingen en aanbevelingen voor de installateur**  
**Instrukcje i ostrzeżenia dla instalatora**

## 1) Warnings:

This manual contains important information regarding safety during installation, therefore before starting installation, it is important that you read all the information contained herein. Store this manual in a safe place for future use.

Due to the dangers which may arise during both the installation and use of the FT210, installation must be carried out in full respect of the laws, provisions and rules currently in force in order to ensure maximum safety.

**According to the most recent European legislation, the automation of a door or gate is governed by the provisions listed in Directive 98/37/CE (Machine Directive) and, more specifically, to provisions: EN 13241-1 (harmonized standard); EN 12445; EN 12453 and EN 12635, which enable to declare the conformity of the product to the machine directive.**

Further information, risk analysis guidelines and how to draw up the Technical Documentation is available at: [www.nice-foryou.com](http://www.nice-foryou.com). This manual has been especially written for use by qualified fitters, none of the information provided in this manual can be considered as being of interest to end users!

- The use of FT210 which is not explicitly provided for in these instructions is not permitted. Improper use may cause damage and personal injury.
- Do not modify any components unless such action is specified in these instructions. Operations of this kind are likely to lead to malfunctions. NICE disclaims any liability for damage resulting from modified products.
- FT210 must only function through TX-RX direct interpolation. The use of through reflection is prohibited.

- Use suitable conductors for the electrical connections as specified in the "installation" chapter.
- Make sure that the electrical power supply and the other use parameters correspond to the values indicated in "technical characteristics" table.
- The manufacture of safety devices for automatic doors and gates is subjected to the following standards:
  - EN 12453 - Industrial, commercial and garage doors and gates. Safety in use of power operated doors - Requirements.
  - EN 12978 - Industrial, commercial and garage doors and gates. Safety devices for power operated doors and gates - Requirements and test methods.

The installation and connection of the FT210 as a safety device must be performed in compliance to the said standards, if the necessary provisions are not taken, this will be automatically considered as negligence and deliberate abuse.

Particular warnings concerning the suitable use of this product in relation to the 89/336/EEC "Electromagnetic Compatibility" Directive and subsequent modifications 92/31/EEC and 93/68/EEC:

This product has been subjected to tests regarding the electromagnetic compatibility in the most critical of use conditions, in the configurations foreseen in this instructions manual and in combination with articles present in the Nice S.p.a. product catalogue. The electromagnetic compatibility may not be guaranteed if used in configurations or with other products that have not been foreseen; the use of the product is prohibited in these situations until the correspondence to the requirements foreseen by the directive have been verified by those performing the installation.

## 2) Product description and applications

FT210 is a device that resolves the problems of electrical connections of sensitive edges on the moving leaf. The device comprises a battery powered infrared beam transmitter (TX) that is positioned on the mobile leaf on which is connected the sensitive edge. In addition to this is a normally powered receiver (RX) which is positioned on the fixed section: 12÷24Vac/dc.

The 8,2kΩ constant resistance type sensitive edge is continually controlled by the transmitter and the activation or deactivation is transmitted to the receiver. Based on the status of the sensitive edge, the RX receiver interprets the information received and, on the basis of the on-board status, activates/deactivates the two output relays ALT and ALT1 (also PHOTO if jumper JP2 of receiver is deactivated See table 2). Communication between the TX and the RX is codified by means of high security techniques, such that the entire device complies to the failsafe category 3 according to the EN 954-1 standard and can therefore be used in EN 12978 standard PSPE systems.

**The FT210 photocell assembled following the instructions and including the TCB65 sensitive edge, has been certified by the manufacturer as conforming to the following standards:**

- EN 954-1 - Machine safety - Parts of the control system related to safety - General design principles
- EN 1760-2 - Machine safety - Pressure sensitive protection

devices - General design and test principles for pressure sensitive edges and bars.

- EN 12978 - Industrial, commercial and garage doors and gates. Safety devices for power operated doors and gates - Test methods and requirements.

**Warning:** the FT210 does not comprise a complete safety device but is only part of it!

The TX and RX are positioned so that the optical communication takes place through the gap (see figure 1), the device can also be used as a presence sensor (type D according to the EN 12453 standard). In fact, the object that interrupts the beam deactivates the third relay of output PHOTO.

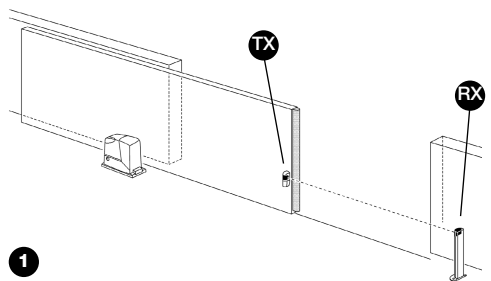

Because the F210 photocells have a horizontal scope of 210° and a vertical scope of 30°, they can also be applied on uneven surfaces where the correct alignment between TX and RX is not normally possible (see figure 2).

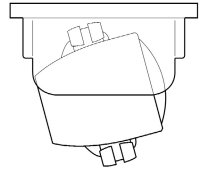
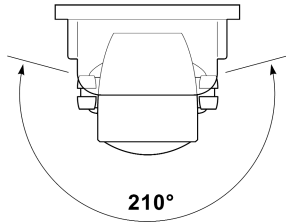
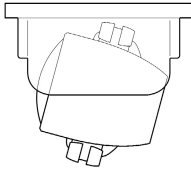

2

### 3) Installation

**⚠ The system must be disconnected from the mains power supply during installation. If buffer batteries are present, these must also be disconnected.**

#### 3.1) Preliminary checks

Due to the peculiarity and uniqueness of the product, certain aspects concerning the operating principles must be evaluated before proceeding with the installation in order to ensure maximum safety and functionality.

- Check carefully that the use parameters conform to the data indicated in the “technical characteristics” chapter. If in doubt, do not use the product and ask clarification from the Nice technical assistance department.
- The transmitter continuously controls the status of the sensitive edge and transmits the information to the receiver. In order to reduce the consumption of the battery and maintain the required safety level, this operation is performed with 2 different “speeds”: SLOW when the gate is at a standstill; FAST when the gate is moving. The transmitter detects when the gate is moving through a special sensor that detects the vibration of the moving gate. As soon as the gate begins to move the transmitter switches to the FAST mode and remains so until the gate is motionless for 10 or 90 seconds (see jumpers JP2 and JP3 in table 1).
- In order to guarantee the required safety level, the receiver must detect the status of the gate, above all to verify if the SLOW or FAST mode of the gate is correct.

This control mechanism occurs through the “PHOTOTEST” input of the receiver (see connection examples in figures 18 and 19). A Phototest is normally performed in the control unit at the beginning of each manoeuvre. In this way the receiver of the FT210 is informed that the gate is about to move.

- If the control unit does not have Phototest the FT210 can in any case be used by connecting the PHOTOTEST input of the FT210 to the SCA (Gate open indicator) output of the control unit. In this case a flashing signal should be present on the SCA output during the entire duration of the movement (see the connection example in figure 20).
- If the control unit does not even have an SCA output, the FT210 should be programmed in the continuous FAST mode by disconnecting the JP3 jumper on the TX (see table 1).
- In the control unit in which the beginning of the opening manoeuvre and the automatic closure is performed, the communication from the FAST mode to the SLOW mode must be held for 90 seconds when the gate stops (see JP2 in table 1). In this way the TX remains in the FAST mode for the entire opening time of the gate. The pause time of the control unit must obviously be less than 90 seconds.

- FT210 has been designed not to interfere with and not to be interfered with by other photocells, meaning that the FT210 can be used along with other photocells. Functioning is guaranteed with at least one other couple of Nice photocells whereas functioning may not be guaranteed with more than one couple or photocells of another make. To check that there are no effects caused by other devices, carefully perform the testing procedure indicated in chapter 4 and check the related signals in table 5. Two FT210 devices can in any case be placed to control the front and rear parts of the same gate, being that the two TX transmit the signals in the opposite direction.
- Two FT210 devices cannot be positioned to control the same area. If a receiver receives the signal of two transmitters, it activates the “safety” mode and blocks the gate movement. See the related signal in table 5.

Figure 3 illustrates an example of correct installation.

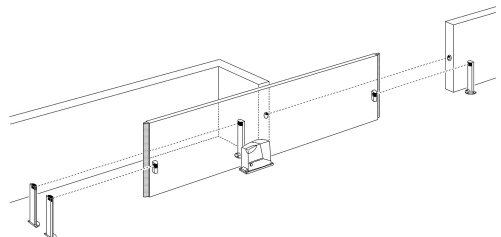

3

- The FT210 TX transmitter emits a beam with an angle of approximately  $\pm 4^\circ$ , therefore a perfect alignment between TX and RX is necessary that remains intact throughout the entire course of the gate.

Figure 4 illustrates an example of correct assembly; figure 5 illustrates two examples of incorrect assembly.

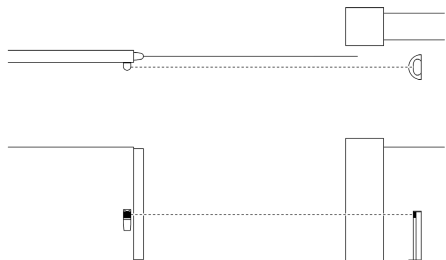

4

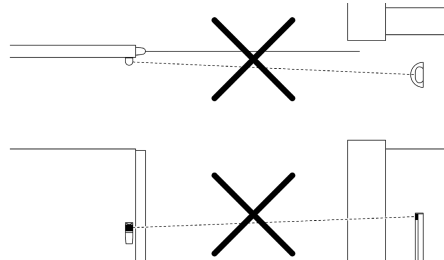

5

- If necessary, the receiver can be fitted on a special MOCF post with related FA2 accessories (see figure 6), or fixed to the wall. In this case the cables can arrive from the base (see figure 7) or below, in which case it is necessary to use "PG9" type cable clip (see figure 8).

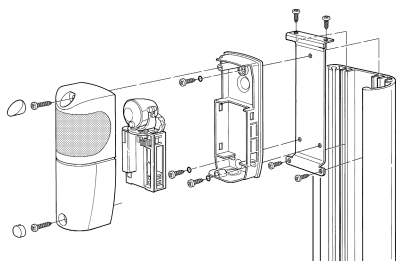

6

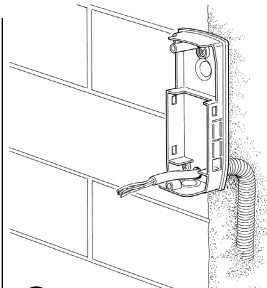

7

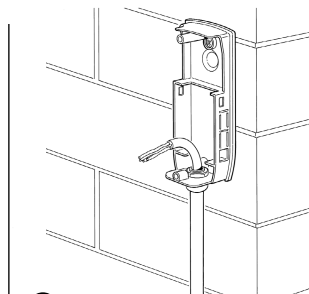

8

### 3.2 Fixing of the devices

Perform the installation and fixing of the devices following the operations below:

- To separate the control unit from the base, use a screwdriver to lever the three clips as indicated in fig. 9
- Fix the receiver as shown in fig. 10.

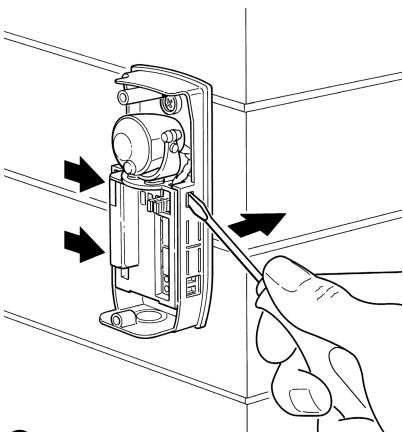

9

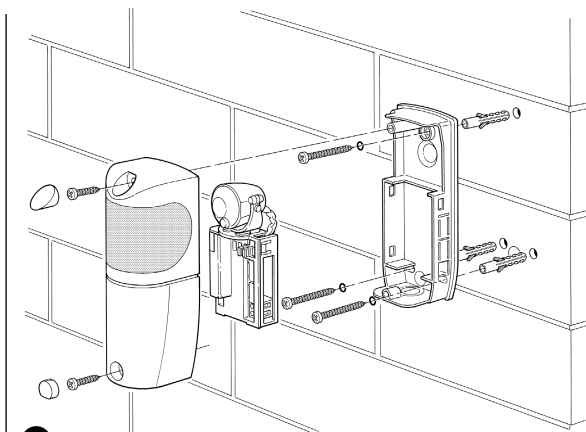

10

3. Assemble the transmitter on the mobile leaf as shown in figure 11.

4. Connect the 8,2K $\Omega$ , constant resistance type sensitive edge on the transmitter as shown in figure 12. The resistance on the TX terminals is removed and used as a termination on the sensitive edge or does not need to be used if the sensitive edge already has a terminating resistance.

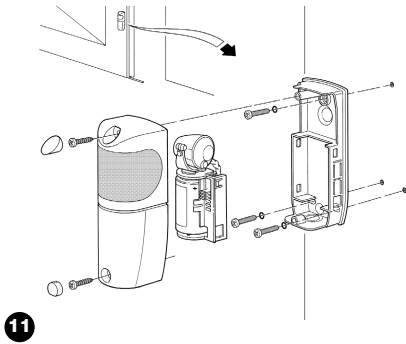

11

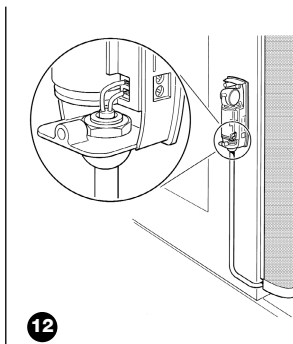

12

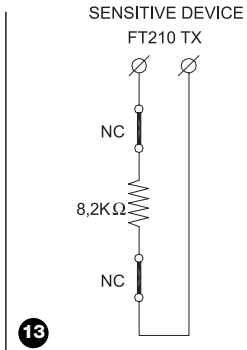

13

If the sensitive edge has an output with 2 separate NC contacts, it can be connected as shown in figure 13 placing the 8,2K $\Omega$  resistance in series between the two contacts. Make sure that the sensitive edge complies with the failsafe category 3 according to the EN 954-1 standard.

**Warning:** do not use sensitive edges that have only one NC type contact because they do not have the necessary failsafe category required by the said standard.

5. Carry out the electrical connections following that which is indicated in the control unit instructions manual. Also see the connection examples in chapter 3.3 “Electrical connections”.

6. Direct the lenses as shown in fig. 14 in order to obtain the correct alignment between the TX and RX. The correct alignment will be verified in chapter 4 “Testing”.

7. Program the jumpers on both the TX and RX (see figure 15) for the desired operation following that indicated in table 1 and 2. Position the jumpers that are not used in their locations for future use (see figures 16 and 17)

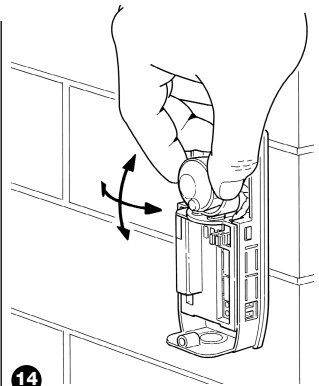

14

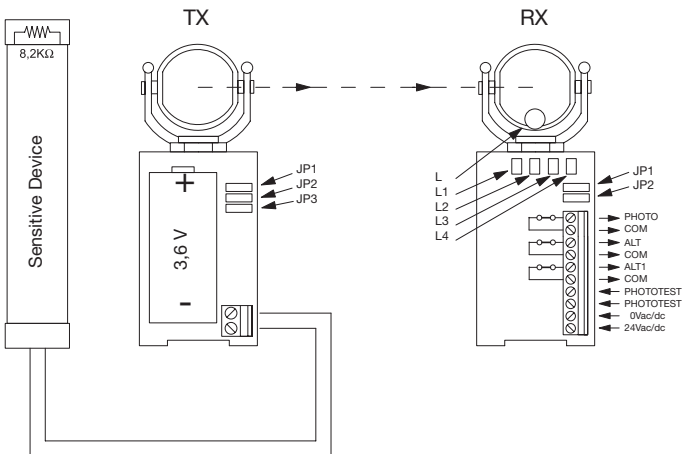

15

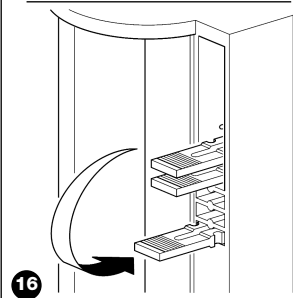

16

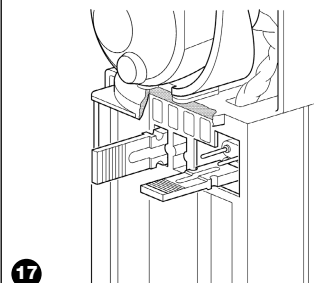

17

**Table 1: TX transmitter jumpers**

Jumper	Position	Description
JP1	Connected	Transmitter power suitable for gates up to 15 meters.
	Disconnected	Transmitter power suitable for gates up to 7 meters.
JP2	Connected	Change over to SLOW transmission after 10 seconds from the end of the manoeuvre (see JP3).
	Disconnected	Change over to SLOW transmission after 90 seconds from the end of the manoeuvre (see JP3).
JP3	Connected	Change over to SLOW transmission at the end of the manoeuvre.
	Disconnected	Never changes over to SLOW transmission but remains in the FAST mode.

**Table 2: RX receiver jumpers**

Jumper	Position	Description
JP1	Connected	Phototest input connected to the Phototest output of the control unit.
	Disconnected	Phototest input connected to the S.C.A. output of the control unit; or the input Phototest disconnected if the control unit is not fitted with Phototest or output SCA (Caution: possible only with JP3 on TX deactivated)
JP2	Connected	The interruption of the infrared beam causes the PHOTO contact to open. The activation of the sensitive edge causes the ALT contact to open and the ALT1 after 1.5 seconds.
	Disconnected	The interruption of the infrared beam causes the PHOTO contact to open. The activation of the sensitive edge causes the ALT contact to open and the ALT1 after 1.5 seconds. To be used in control units that do not foresee the inversion when ALT cuts in.

### 3.3) Electrical connections

This chapter describes the electrical connections and illustrates various possible connection layouts based on the type of control unit used on the automation system. If in doubt, do not use the product and contact the Nice technical assistance department.

**Table 3: List of connections**

Connection	Cable type	Max. length	Description
12÷24V	2x0,5mm <sup>2</sup>	30m	AC or DC receiver power supply
Phototest	2x0,25mm <sup>2</sup>	30m	Start of manoeuvre test input, which can be connected to the AC or DC voltage and is not limited by the power supply terminals.
Output contacts	2x0,25mm <sup>2</sup>	30m	Output relay contacts; normally closed (NC) when the receiver is powered and active (see table 4)

**Table 4: RX output description**

Output	Relay contact	Description
PHOTO	Closed	There are no obstacles and the TX data is received correctly.
	Open	Obstacles are present and the TX data is not received.
The PHOTO output (Photocell) must be connected to the control unit input that causes the inversion of the manoeuvre, which is normally used by the D type presence sensor.		
ALT	Closed	No pressure is applied to the sensitive edge connected to the TX.
	Open	Pressure is applied to the sensitive edge connected to the TX.
The ALT output must be connected to the control unit input that causes the stop and eventual inversion of the manoeuvre, which is normally used by PSPE pressure sensitive safety devices.		
ALT1	Closed	No pressure is applied to the sensitive edge connected to the TX.
	Open	After 1.5 seconds if pressure is applied to the sensitive edge connected to the TX.

The ALT1 output must be connected to the second input of the control unit that causes the stop and eventual inversion of the manoeuvre, which is normally used by PSPE pressure sensitive safety devices.

In the event that this second input is not available on the control unit it is possible:

- to use the ALT1 output to control a relay of suitable capacity that directly cuts the power to the motor (see figure 18).
- not to use the ALT1 output and disconnect the JP2 on the RX, in this way when the sensitive edge is activated the PHOTO contact is opened which also guarantees the failsafe category 3.

### 3.3.1) General connection example

Figure 18 shows a connection example of the FT210 to a general control unit with PHOTO input; ALT has a Phototest output. In this configuration, set the RX jumpers as follows:

- JP1 **connected**
- JP2 **activated**, if activation of the ALT input of the control unit causes shutdown and inversion of movement (in this way the relay connected to ALT1 in figure 18 can be eliminated and the contact of ALT1 can be placed in series to PHOTO and connected to the PHOTO input of the control unit as shown in figure 19 and 20)
- **deactivated**, if activation of the ALT input of the control unit causes only shutdown of movement

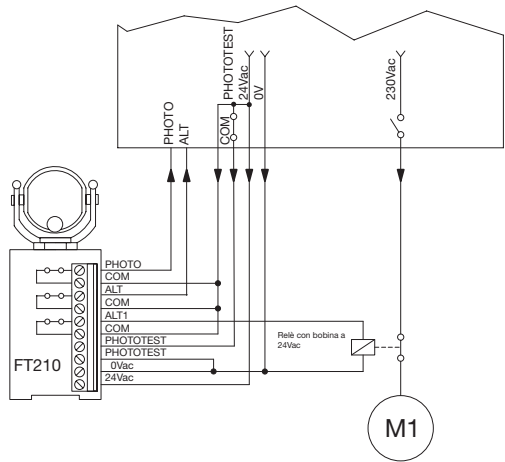

18

### 3.3.2) Connection example with “Phototest” equipped control unit

Figure 19 shows a connection example of the FT210 to the ROBO “RO300” model gearmotor with the use of the Phototest function. In this configuration, set the RX jumpers as follows:

- JP1 **connected**
- JP2 **connected** (control unit with inversion of movement on activation of ALT input)

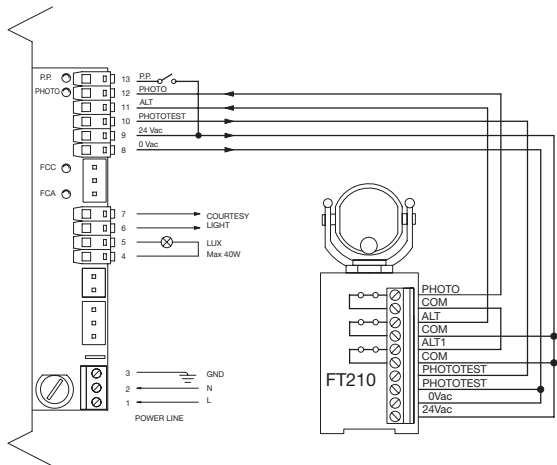

19

### 3.3.3) Connection example with “SCA” equipped control unit

Figure 20 shows a connection example of the FT210 to the ROBO “RO1000” model gearmotor with the use of the SCA output. In this configuration, set the RX receiver jumpers as follows:

- JP1 **disconnected**
- JP2 **activated** (control unit with inversion of movement on activation of ALT input)

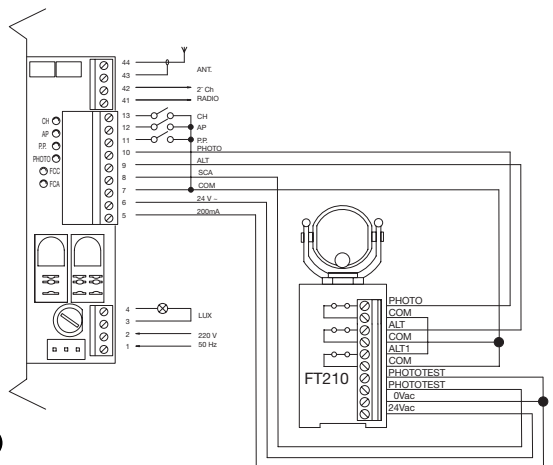

20

### 3.3.4) Connection of 2 or more sensitive edges

The FT210 has only one sensitive edge input, but 2 or more sensitive edges that perform the same function can be cascade connected one after the other as in figure 21 applying a single 8.2K $\Omega$  termination resistance.

**Warning:** the constant resistance devices must be cascade connected and never in series or parallel to one another!

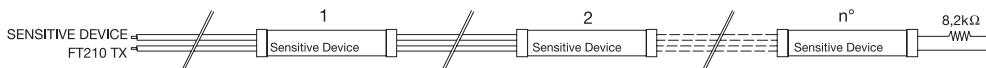

21

## 4) Testing

Each individual component of the automation system requires a specific testing phase. Perform the following sequence of operations for the testing of the FT210. The sequence is repeated for each device in the event 2 devices are present, one on the front of the gate and one on the back of the gate (see figure 3).

**Warning:** some points require that the gate is in movement for the control; as the automation MAY not be adequately SAFE, the maximum attention must be given during these controls.

1. Make sure that all that is foreseen in the present manual, in particular chapters 1 "Warnings" and 3 "Installation" is fully abided by.
2. Release and fully open the gate leaf so that the TX is at the maximum possible distance from the RX.
3. Make sure that there are no obstacles between the TX and the RX.
4. If present, disconnect the power supply to the receiver and remove the battery from the transmitter.
5. Disconnect the sensitive device from the TX terminals and measure the resistance of the device with an ohmmeter, checking that the value is between 7700 $\Omega$  and 8700 $\Omega$  (nominal 8200 $\Omega$ ).
6. Push the sensitive edge to activate it and measure once again the resistance. Check that the resistance is lower than 1000 $\Omega$  or higher than 16500 $\Omega$ .
7. Reconnect the sensitive device to the TX terminals.
8. Connect the power supply to the receiver and check that the L1 (Ir Level) L2 (Phototest Ko) and L3 (Sensitive Device Ko) LEDs are on. Check that the L4 LED (Sensitive Device Ok) is off (see figure 30).
9. Remove the JP3 jumper on the TX so that it always transmits in the FAST mode.
10. If the distance between the TX and the RX exceeds 7 m check that the JP1 jumper on the TX is connected (this meaning programmed for distances up to 15 m).
11. Insert the FTA1 or FTA2 battery into the TX (see figure 33 or 34).
12. Check that the L1 (Ir level) LED on the RX receiver flashes; the L2 (Phototest Ko) LED and the L4 (Sensitive device Ok) LEDs are on and that the L3 ((Sensitive device Ko) LED is off.
13. If necessary, improve the alignment by directing the TX and RX lenses as shown in figure 14. By performing the L1 (Ir level) LED signal the speed of the flashing is less and the alignment is greater. The adjustment is at its best when the LED flashes slowly at a maximum of 3 flashes a second.
14. Repeat the test placing the top protection covers both on TX and RX. Note that the RX cover is fitted with a damper filter that simulates adverse weather conditions which could arise during use.
15. Move the gate leaf along the entire course and check, through the flashes of the L1 LED, that the alignment remains above the optimum.
16. To check the optical presence sensor (type D) of the FT210, and to make sure that there is no interference with other devices, pass a 50 mm diameter cylinder across the optical axis, first near the TX, then near the RX and finally between the two (see figure 22) and make sure that in all cases the device is triggered, switching from the active status to the alarm status (LED L1 ON) and vice versa.

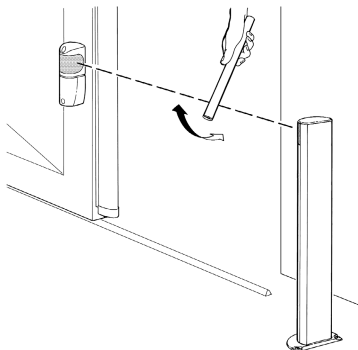

22



**17.** To check the PSPE pressure sensitive device of the FT210, push and release the sensitive edge as shown in figure 23 and check that the L4 LED turns off and that the L3 LED turns on and vice versa.

**18.** If this is the preferred program, connect the JP3 jumper on the TX so that the transmission changes over to SLOW a few seconds after the movement has finished.

**19.** If the operation in the previous point has been performed; check that the transmitter changes over to SLOW after the foreseen time has past (see JP2 in table 1). The transmission in the SLOW mode can be recognised through four short flashes of the L1 LED followed by a pause.

**20.** Mechanically connect the leaf to the motor and perform a manoeuvre of the gate.

In the meantime, check that the L2 LED turns off at the beginning of the manoeuvre, indicating that the vibration sensor test of the moving gate has been performed correctly.

**21.** Perform various gate manoeuvres and check that the opening and closing are correctly performed without the inversion of the movement.

**22.** Perform further manoeuvres, and during the closure activate the optical presence sensor as indicated in point 15 and check that the foreseen action is performed such as the inversion of the movement.

**23.** Perform additional manoeuvres and during the closure activate the sensitive edge as indicated in point 16 and check that the foreseen action is performed such as the inversion of the movement.

**24.** The control of the FT210 optical presence sensor (type D), according to the EN 12445 standard, is performed with the 700x300x200mm test parallelepiped with 3 black faces and 3 polished white or mirrored faces as indicated in figure 24 and according to chapter 7 of the EN 12445:2000 standard (or enclosure A of prEN12445:2005).

**25.** The control of the PSPE pressure sensitive device of the FT210 according to the EN 12445 standard, is performed by measuring the force at the points foreseen in chapter 5 of the EN 12445 standard, if the hazardous situations, which have been caused by the movement of the leaf, have been safeguarded through the limitation of the impact force (type C).

**26.** After verifying all the above points, remove the damper filter from the glass panel on the RX receiver as shown in figure 25.

**27.** Make sure that all casings of the various devices are closed when testing is complete

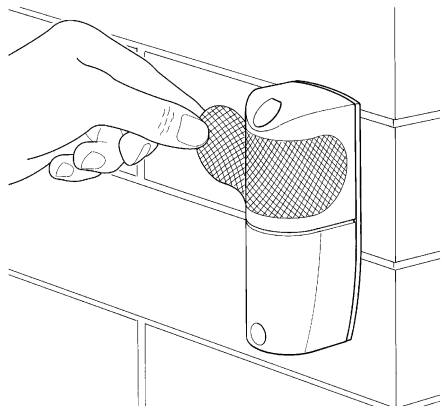
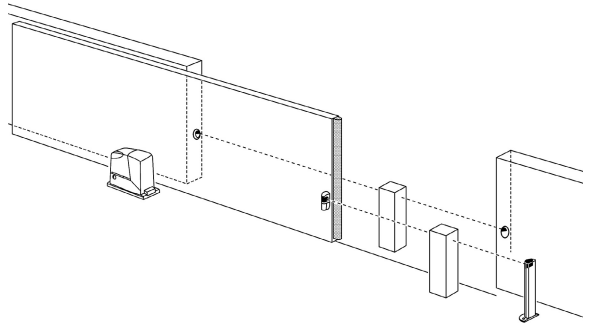
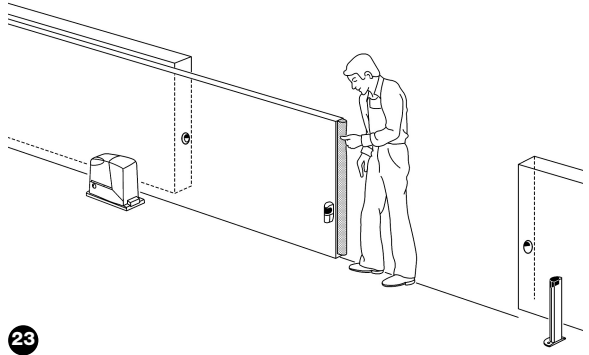

## 5) Additional information

Personalisation and how to look for and deal with faults on the FT210 will be dealt with in this chapter.

### 5.1) Example of how the FT210 can be used as photocell

The FT210 can be used as a simple type D presence sensor without having to connect to the sensitive edge.

Figure 26 illustrates a connection example with this type of application of the FT210 photocell device.

In this case it is necessary to:

1. Perform the assembly as indicated in the "Installation" paragraph.
2. Deactivate jumper JP3 of the transmitter to ensure that transmission is always HIGH SPEED.
3. Use the receiver PHOTO output only
4. Connect and use the Phototest if the control unit supports this function. In this case jumper JP1 of the receiver must be inserted.
5. If the control unit has output SCA only, connect it to the Phototest input of the receiver. Jumper JP1 of the receiver must be deactivated.
6. If there is not usable output on the control unit (Phototest or SCA), leave the Phototest input of the receiver and deactivate the jumper JP1 of the receiver.

26

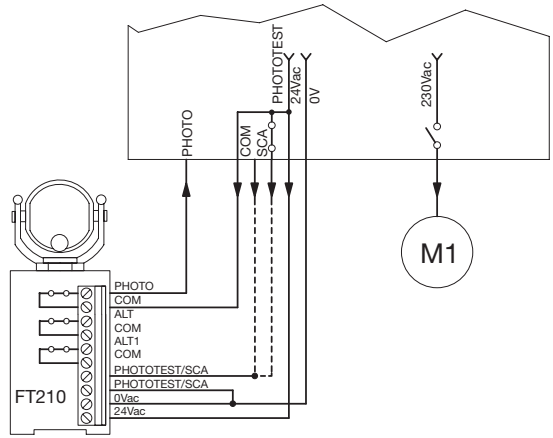

**Note:** The FAST transmission mode reduces the battery life of the transmitter. In this case the estimated life of a C type battery (FTA1 kit) is as follows:

- approximately 24 months for gates up to 7 m (JP1 jumper of the transmitter disconnected)
- approximately 18 months for gates up to 15 m (JP1 jumper of the transmitter connected)

### 5.2) Example of using FT210 only as detector of sensitive edge detector

If FT210 is used only as detector of the sensitive edge status, and therefore without the presence detector function, the photocell device should be installed as shown in figure 27.

In this case, the following is necessary:

1. Perform the assembly phase as described in the paragraph "Installation".
2. Connect the receiver of FT210 to the control unit as shown in figure 28, placing the contacts PHOTO and ALT in series.
3. Insert Jumper JP2 of the receiver.
4. Connect and use Phototest if the control unit manages this function. In this case jumper JP1 of the receiver and jumper JP3 of the transmitter must be inserted.
5. If the control unit has output SCA only, connect it to the Phototest input of the receiver. Jumper JP1 of the receiver must be deactivated, while jumper JP3 of the transmitter must be inserted.
6. If there is not usable output on the control unit (Phototest or SCA), do not connect anything to the Phototest input of the receiver, deactivate the jumper JP1 of the receiver and jumper JP3 of the transmitter.

27

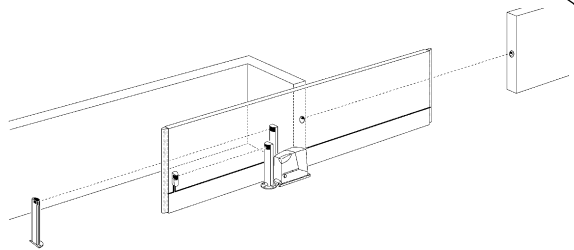

28

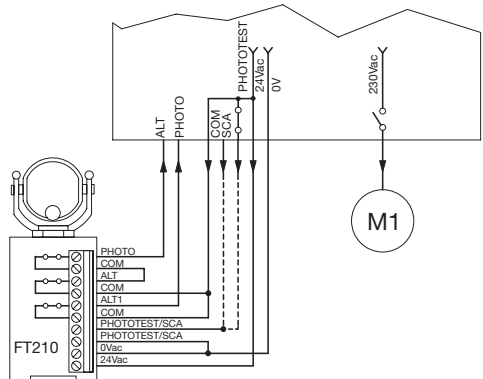

### 5.3) Example of connection of FT210 to control unit with ALT input with constant resistance at 8.2kohm

If the control unit has an ALT input with constant resistance of 8.2kohm, place a 8.2kohm resistance in series with the two contacts PHOTO and ALT of the receiver as shown in figure 29

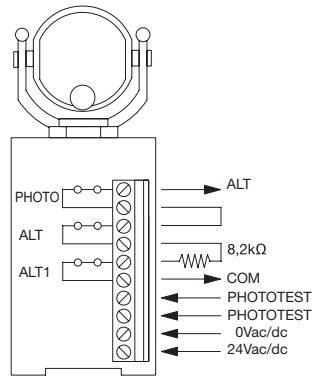

29

### 5.4) Signals

The FT210 receiver has various LED signals (see figure 30) that give luminous signals based on the operational status.

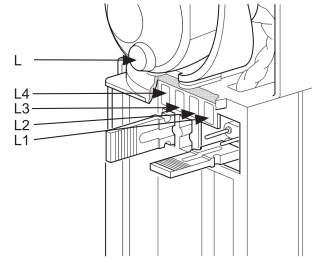

30

Table 5: Signals		
LED L (red)	Cause	Action
2 short flashes Pause 2 short flashes	TX flat battery signal.	Replace the transmitter battery as soon as possible with another of the same type.
LED L1 (red)	Cause	Action
Regular flash	The rate of the flash indicates the quality of the reception: the slower the flash the greater the reception.	Everything Ok if the flash is slow: maximum 3 per second, otherwise the alignment of the TX and RX must be checked.
On	No signal, The "PHOTO" contact remains open.	Remove the obstacle or improve the TX and RX alignment.
4 short flashes Pause 4 short flashes	The transmitter is in the SLOW mode.	Everything Ok if the gate is not moving.
5 short flashes Pause 5 short flashes	The receiver receives interference from unrecognisable infrared signals.	An unknown transmitter is sending a signal towards the receiver, try to remove the interference; check the alignment of all devices present.
7 short flashes Pause 7 short flashes	The receiver receives the signal from a second FT210 transmitter.	Eliminate the second transmitter. Two FT210 transmitters cannot be positioned in the same area.
LED L2 (yellow)	Cause	Action
On	Signals an error during the test at the beginning of the manoeuvre and the transmitter changes over to the FAST mode.	Connection or programming of the PHOTOTEST input error. Possible poor functioning of the movement sensor.
Off	The test at the beginning of the last manoeuvre was correct.	Everything Ok
LED L3 (red)	Cause	Action
On (ALT contact: open)	The sensitive edge that is connected to the transmitter is active.	Check the reason the edge was activated.
Off (ALT contact: closed)	The sensitive edge connected to the transmitter is not active.	Everything Ok
LED L4 (green)	Cause	Action
On (ALT contact: closed)	The sensitive edge connected to the transmitter is not active.	Everything Ok
Off (ALT contact: open)	The sensitive edge connected to the transmitter is active.	Check the reason the edge was activated.

## 5.5) Troubleshooting

Table 6 gives possible indications on how to deal with malfunctions that may be met during installation or due to a fault.

**Table 6: Fault diagnostics**

Symptoms	Advisable checks
The gate cannot be controlled; all the LEDs on the FT210 receiver are off	Check if the receiver is connected to the power supply by measuring the voltage on the 12/24V terminals.
The gates starts to move but stops after 1 second; LED 2 (yellow) is on	The outcome of the test at the beginning of the manoeuvre was negative and there is a possible connection or programming error or there is a fault in the TX movement sensor of the gate.
The gate stops during the manoeuvre the manoeuvre is inverted; the LED L1 (red) is constantly on.	Check for possible obstacles or the alignment of the TX and RX through the entire course of the gate.
The gate stops during the movement or the manoeuvre is inverted; the LED L3 (red) is on and the LED L4 (green) is off	The sensitive edge has cut-in. Remove the possible obstacle and check that the sensitive edge is working correctly.
Sometimes the gate stops during the movement or the manoeuvre is inverted; the LED L1 (red) flashes rapidly when the gate is open.	Check the alignment between the TX and RX throughout the entire course of the gate.
On activation of the device, the receiver has yellow led L2 lit and red led L1 flashing. If the infrared beam is interrupted, led L1 is permanently lit, but no relay activation is heard	The receiver is set to Phototest mode (JP1 inserted) but has still not performed the test at the start of the manoeuvre. If the central has the Phototest function, leave jumper JP1 of the receiver inserted, check the connections and perform an automation manoeuvre. If the control does not have the Phototest function, the jumper JP1 must be inserted incorrectly. Deactivate the jumper and check that the relays are activated, interrupting the infrared beam.
Sometimes the gate stops during the movement or the manoeuvre is inverted; sometimes everything blocks and cannot be controlled; the LED L2 (red) continues to make 2 short flashes.	The TX battery is flat and communication between the TX and RX does not occur when conditions are poor. The flashing LED L (red) indicates that the battery need changing.

## 6) Maintenance

The FT210 does not require any particular maintenance, however a control should be performed at least once every six months to check the integrity of FT210 photocell (presence of dampness, rust, etc), cleaning of the external casing and testing as described in chapter 4 "Testing". The FT210 photocell has been designed to function under normal conditions for at least 10 years, therefore maintenance should be performed more frequently once this period has expired.

## 7) Disposal

As in installation, also at the end of product lifetime, the disassembly and scrapping operations must be performed by qualified personnel. This product is made up of different types of material, some of which can be recycled while others must be disposed of. Seek information on the recycling and disposal systems envisaged by the local regulations in your area for this product category.

**Caution:** some parts of the product may contain pollutant or hazardous substances which, if disposed of into the environment, may cause serious damage to the environment or physical health.

As indicated by the symbol in figure 31, disposal of this product in domestic waste is strictly prohibited. Separate the waste into

categories for disposal, according to the methods envisaged by current legislation in your area, or return the product to the retailer when purchasing a new version. Local legislation may envisage serious fines in the event of abusive disposal of this product.



**Warning:** the product operates with batteries that could contain polluting substances and therefore should not be disposed of along with household waste. After they have been removed from the product (see paragraph "Battery replacement" in chapter "FT210B installation instructions and warnings") they should be disposed of in compliance with the legislations locally in force.

## 8) Accessories

The following accessories are available:

- FA1: metal vandal-proof casing, fitted as in figure 32
- FA2: ixing brackets for "MOCF" posts, fitted as in figure 33
- FTA1: 3.6V battery; 7Ah type C, fitted as in figure 34
- FTA2: 3.6V battery; 2Ah type AA, fitted as in figure 35

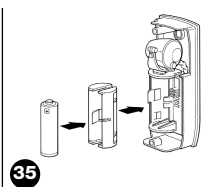
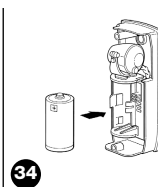
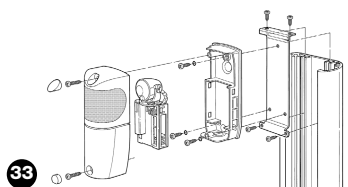
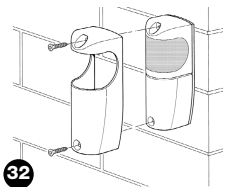

## 9) Technical characteristics

In order to improve its products, NICE S.p.a. reserves the right to modify them at any time without prior notice. In any case, the manufacturer guarantees their functionality and fitness for the intended purposes. Note: all the technical characteristics refer to a temperature of 20°C.

FT210 technical characteristics	
Type	Device for the optical status transmission of a constant resistance sensitive edge positioned on the moving part, comprising a battery powered infrared transmitter (TX) that is positioned on the moving leaf, to which is connected the sensitive edge, and a receiver (RX) positioned on the fixed part.
Adopted technology	TX-RX direct optical interpolation with modulated and coded infrared beam.
Receiver power supply	12÷24Vac/dc; limits: 10÷35 Vdc; 11÷28Vac 50/60Hz; with EN 61558 insulating transformer.
Receiver absorbed current	Approx. 120mA at 12Vdc; 70mA at 24Vac.
Phototest input voltage	The same limits as "Receiver power supply".
Transmitter power supply	3.6 V with type C or AA lithium battery.
Transmitter battery life	Estimated at approx. 15 years with the type C battery, 7Ah capacity; ("residential" use: TX-RX distance up to 7m; with 20 manoeuvres per day of 90") Estimated at approx. 5.5 years with the type C battery, 7Ah capacity; ("industrial" use: TX-RX distance up to 15m; with 200 manoeuvres per day of 90") Estimated at approx. 6 years with the type AA battery, 2Ah capacity; ("residential" use: TX-RX distance up to 7m; with 20 manoeuvres per day of 90")
Device input range Sensitive (Rs)	Typical 8,2KΩ +22%/-65% for the on status (ON) ON limits: with Rs > 2.870Ω and Rs < 10.010Ω OFF limits: with Rs < 2.590Ω or Rs > 11.060Ω
Type D presence sensor detection capacity	Opaque objects located on the optical axis between TX and RX, larger than 50 mm and moving slower than 1.6m/s.
TX transmission angle	+/- 4° (value taken at 50% of the capacity).
RX reception angle	+/- 3° (value taken at 50% of the capacity).
Directional capacity	approx. 210° on the horizontal axis and 30° on the vertical axis
Useful range	7 m or 15m (with JP1 inserted on TX) for maximum TX-RX misalignment ±2° (the range may be further reduced in the presence of particularly intense atmospheric conditions: fog, rain, snow, dust, etc.)
Maximum range (under optimum conditions)	15m or 30m (with JP1 inserted on TX) for maximum TX-RX misalignment ± 2°.
PHOTO output response time	<45ms (typical 31ms).
ALT output response time	<30ms (typical 28ms).
ALT1 output response time	1.5s ± 3%.
Failsafe category	3 or 2 (according to the EN 954-1 standard) according to the type of the output connections and PHOTOTEST input
Output relay contacts capacity	Maximum 0.5A and maximum 48Vac (resistive load: cosφ=1).
Output relay contacts duration	Mechanical life > 1.000.000 cycles; electrical > 200.000 cycles (resistive load: 0.25A; 24Vdc).
Use in acid, saline or potentially explosive atmosphere	No.
Assembly	RX: Vertically wall mounted or on "MOCF" posts with "FA2" bracket. TX: directly on the gate with the supplied screws.
Protection class casing	IP44.
Operating temperature	-20 ÷55°C.
Dimensions	46 x 128 h 45mm.
Weight	Receiver 135g. Transmitter 165 g with FTA1 or 140 g with FTA2

These instructions can be incorporated with the "Instructions and warnings for the use of the automation" which the installer must give the owner of the automation, and must be incorporated by them.

- **Maintenance:** Like any machine, your automation needs regular periodic maintenance to ensure its long life and total safety. Arrange a periodic maintenance schedule with your installation technician. Nice recommends that maintenance checks should be carried out every six months for normal domestic use, but this interval may vary depending on the intensity of use. Only qualified personnel are authorized to carry out checks, maintenance operations and repairs.
- Do not modify the system or its programming and adjustment parameters in any way, even if you feel capable of doing it: your installation technician is responsible for the system.
- The final test, the periodic maintenance operations and any repairs must be documented by the person who has performed them; these documents must remain under the custody of the owner of the system
- The only recommended maintenance operations that the user can perform periodically concern the cleaning of the photocell glasses and the removal of leaves and debris that may impede the automation. To prevent anyone from activating the gate, release the automation system and use a slightly damp cloth to clean.
- Disposal: At the end of its useful life, the automation must be dismantled by qualified personnel, and the materials must be recycled or disposed of in compliance with the legislation locally in force.

**Replacement of the FT210 battery**

The transmitter on the mobile leaf of the gate has a special 3.6 V lithium battery that, depending on the use conditions, has an estimated life of approximately 2 years. A signal is given a few months before the battery is completely flat in order to give ample time for replacement.

It's time to change the battery if the **receiver** on the fixed section (on the wall as in figure A or on the post as in figure B) gives the following signal: **2 short flashes followed by a 1 second pause.**

The battery is housed in the **transmitter** on the gate leaf; for replacement:

- 1) Remove the screw caps as in figure C.
- 2) Unscrew the screws that hold the cover and remove it as in figure C.
- 3) Use a screwdriver to lever out the flat battery.
- 4) Wait about 10 seconds before introducing the new battery.
- 5) Make sure the polarity is correct; the plus is at the top.
- 6) Introduce the battery as in figure D or E depending on the type used.
- 7) Secure the cover with the screws and replace the caps.

There are 2 types of battery:

- FTA1: 3.6V battery; 7Ah type C, fitted as in figure D.
- FTA2: 3.6V battery; 2Ah type AA, fitted as in figure E.

**Caution: batteries used in this product are not normal alkaline versions.**

**Contact Nice s.p.a. to request the spare battery kits "FTA1" or "FTA2".**

**Warning:** the product operates with batteries that could contain polluting substances and therefore should not be disposed of along with household waste. After they have been removed from the product (see paragraph "Battery replacement" in chapter "FT210B installation instructions and warnings") they should be disposed of in compliance with the legislations locally in force.

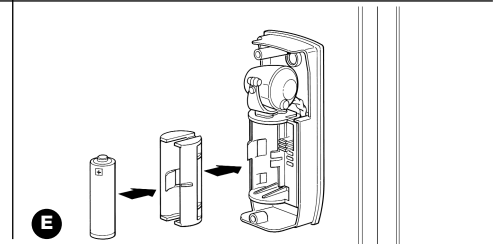
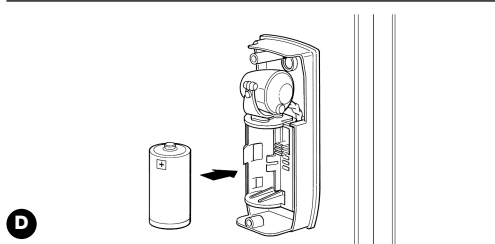
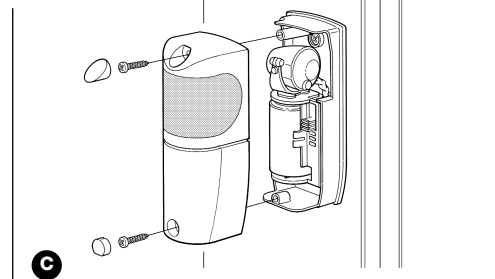
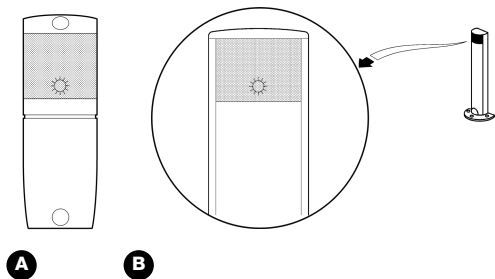



COMPANY  
WITH QUALITY SYSTEM  
CERTIFIED BY DNV  
=ISO 9001/2000=

#### Headquarter

##### Nice SpA

Oderzo TV Italia  
Tel. +39.0422.85.38.38  
Fax +39.0422.85.35.85  
info@niceforyou.com

##### Nice in Italy

##### Nice Padova

Sarmeola di Rubano PD Italia  
Tel. +39.049.89.78.93.2  
Fax +39.049.89.73.85.2  
infopd@niceforyou.com

##### Nice Roma

Roma Italia  
Tel. +39.06.72.67.17.61  
Fax +39.06.72.67.55.20  
inforoma@niceforyou.com

#### Nice worldwide

##### Nice France

Buchelay  
Tel. +33.(0)1.30.33.95.95  
Fax +33.(0)1.30.33.95.96  
info@fr.niceforyou.com

##### Nice Rhône-Alpes

Decines Charpieu France  
Tel. +33.(0)4.78.26.56.53  
Fax +33.(0)4.78.26.57.53  
infoyon@fr.niceforyou.com

##### Nice France Sud

Aubagne France  
Tel. +33.(0)4.42.62.42.52  
Fax +33.(0)4.42.62.42.50  
infomarseille@fr.niceforyou.com

##### Nice Belgium

Leuven (Heverlee)  
Tel. +32.(0)16.38.69.00  
Fax +32.(0)16.38.69.01  
info@be.niceforyou.com

##### Nice España Madrid

Tel. +34.9.16.16.33.00  
Fax +34.9.16.16.30.10  
info@es.niceforyou.com

##### Nice España Barcelona

Tel. +34.9.35.88.34.32  
Fax +34.9.35.88.42.49  
info@es.niceforyou.com

##### Nice Polska

Pruszków  
Tel. +48.22.728.33.22  
Fax +48.22.728.25.10  
info@pl.niceforyou.com

##### Nice UK

Chesterfield  
Tel. +44.87.07.55.30.10  
Fax +44.87.07.55.30.11  
info@uk.niceforyou.com

##### Nice Romania

Cluj Napoca  
Tel/Fax +40.264.45.31.27  
info@ro.niceforyou.com

##### Nice Deutschland

Gelnhausen-Hailer  
Tel. +49.60.51.91.52-0  
Fax +49.60.51.91.52-119  
info@de.niceforyou.com

##### Nice China

Shanghai  
Tel. +86.21.575.701.46  
+86.21.575.701.45  
Fax +86.21.575.701.44  
info@cn.niceforyou.com

##### Nice USA Inc.

Jacksonville, Fl.  
Tel. +001.904.786.7133  
Fax +001.904.786.7640  
info@us.niceforyou.com

# FT210B



Optical Device

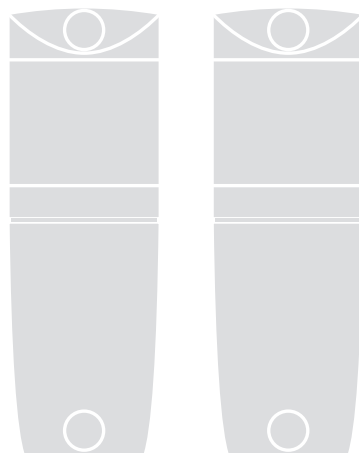

**Installation instructions and warnings**

**Istruzioni ed avvertenze per l'installatore**

**Instructions et avertissements pour l'installateur**

**Anweisungen und Hinweise für den Installateur**

**Instrucciones y advertencias para el instalador**

**Aanwijzingen en aanbevelingen voor de installateur**

**Instrukcje i ostrzeżenia dla instalatora**





# 1) Warnings

This manual contains important information regarding safety during installation, therefore before starting installation, it is important that you read all the information contained herein. Store this manual in a safe place for future use.

Due to the dangers which may arise during both the installation and use of the F210B, installation must be carried out in full respect of the laws, provisions and rules currently in force in order to ensure maximum safety.

**According to the most recent European legislation, the automation of a door or gate is governed by the provisions listed in Directive 98/37/CE (Machine Directive) and, more specifically, by provisions: EN 13241-1 (harmonized standard); EN 12445; EN 12453 and EN 12635, which enable to declare the conformity of the product to the machine directive.**

Further information, risk analysis guidelines and how to draw up the Technical Documentation are available at: [www.niceforyou.com](http://www.niceforyou.com)". This manual has been especially written for use by qualified fitters, none of the information provided in this manual can be considered as being of interest to end users!

- The use of F210B which is not explicitly provided for in these instructions is not permitted. Improper use may cause damage and personal injury.
- Do not modify any components unless such action is specified in these instructions. Operations of this kind are likely to lead to malfunctions. NICE disclaims any liability for damage resulting from modified products.
- FT210B must only function through TX-RX direct interpolation. Use through reflection is prohibited.
- Use suitable conductors for the electrical connections as specified in the "installation" chapter.

- Make sure that the electrical power supply and the other use parameters correspond to the values indicated in "technical characteristics" table.
- The manufacture of safety devices for automatic doors and gates is subjected to the following standards:
  - EN 12453 - Industrial, commercial and garage doors and gates. Safety in use of power operated doors - Requirements
  - EN 12978 - Industrial, commercial and garage doors and gates. Safety devices for power operated doors and gates - Requirements and test methods

The installation and connection of the FT210B as a safety device must be performed in compliance to the said standards, if the necessary provisions are not taken, this will be automatically considered as negligence and deliberate abuse!

Particular warnings concerning the suitable use of this product in relation to the 89/336/EEC "Electromagnetic Compatibility" Directive and subsequent modifications 92/31/EEC and 93/68/EEC:

This product has been subjected to tests regarding the electromagnetic compatibility in the most critical of use conditions, in the configurations foreseen in this instructions manual and in combination with articles present in the Nice S.p.a. product catalogue. The electromagnetic compatibility may not be guaranteed if used in configurations or with other products that have not been foreseen; the use of the product is prohibited in these situations until the correspondence to the requirements foreseen by the directive have been verified by those performing the installation.

# 2) Product description and applications

FT210B is a device with "BlueBUS" technology that resolves the problems of electrical connections of sensitive edges on the moving leaf. The device comprises a battery powered infrared beam transmitter (TX) that is positioned on the mobile leaf on which is connected the sensitive edge. In addition to this is a receiver (RX) which is positioned on the fixed section and connected using just 2 wires to all control units and devices with "BlueBUS" technology.

FT210B can be used in 2 different ways:

- as part of a pressure sensitive safety device (PSPE) through the control of the sensitive edge status
- as a D type presence sensor (photocell) through the control of the breaking of the infrared beam

In the first case, the 8.2kohm constant resistance type sensitive edge is continually controlled by the transmitter and the activation or deactivation is transmitted to the receiver. The RX receiver translates the information and communicates it to the control unit via the "BlueBUS" network. The transmission between TX-RX and the "BlueBUS" communication between the RX and the control unit is codified by means of high security techniques, such that the entire TX/RX/Control unit system complies to the failsafe category 3 according to the EN 954-1 standard and can therefore be used in EN 12978 standard PSPE systems.

In the second case, if the TX and RX are positioned so that the optical communication takes place through the gap (see figure 1), the device can also be used as a presence sensor (type D according to the EN 12453 standard). In fact, the object that interrupts the beam trips the alarm of the presence sensor, which is sent via BlueBUS in a distinct and separate manner depending on the manner in which the sensitive edge has been activated.

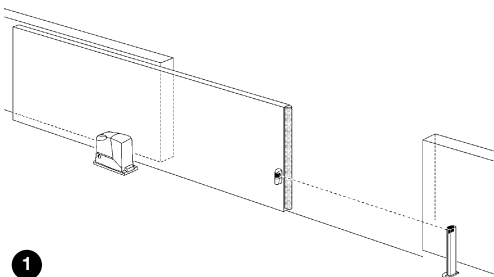

Because the FT210B photocells have a horizontal scope of 210° and a vertical scope of 30°, they can also be applied on uneven surfaces where the correct alignment between TX and RX is not possible (see fig 2).

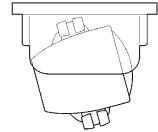
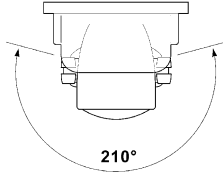
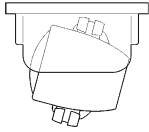

2

**The FT210B photocell assembled following the instructions and including the TCB65 sensitive edge and control unit with BlueBUS technology, has been certified by the manufacturer as totally or partially conforming to the following standards:**

- EN 954-1 - Machine safety - Parts of the control system related to safety - General design principles
- EN 1760-2 - Machine safety - Pressure sensitive protection devices - General design and test principles for pres-

sure sensitive edges and bars.

- EN 12978 - Industrial, commercial and garage doors and gates. Safety devices for motorised doors and gates - Test methods and Requirements

**⚠ The FT210B does not comprise a complete safety device but is only part of it!**

### 3) Installation

**⚠ The system must be disconnected from the mains power supply during installation. If buffer batteries are present, these must also be disconnected.**

#### 3.1) Preliminary checks

- Check carefully that the use parameters conform to the data indicated in the “technical characteristics” chapter. If in doubt, do not use the product and contact the Nice technical assistance department.

Due to the peculiarity and uniqueness of the product, certain aspects concerning the operating principles must be evaluated before proceeding with the installation in order to ensure maximum safety and functionality.

- The transmitter continuously controls the status of the sensitive edge and transmits the information to the receiver. In order to reduce the consumption of the battery and maintain the required safety level, this operation is performed with 2 different “speeds”: SLOW when the gate is at a standstill; FAST when the gate is moving. The transmitter detects the status of the gate through a special sensor that detects the vibration of the moving gate. As soon as the gate begins to move the transmitter switches to the FAST mode and remains so until the gate is motionless for 10 or 90 seconds (see jumpers JP2 and JP3 in table 1). In order to guarantee the required safety level, the receiver must recognise the gate status, above all to check whether the transmitter SLOW and FAST speed is correct. This control mechanism is performed through the BlueBUS. The control unit sends the gate in movement signals throughout the entire movement, and the receiver controls the correct procedure of the transmitter.
- FT210B has been designed not to interfere with and not to be interfered with by other photocells, meaning that the FT210B can be used along with other photocells, but it is necessary to pay attention that:
  1. if photocells with BlueBUS technology are used, the number of photocells to be combined to the FT210B device is

not a problem, as long as they are installed as indicated in Fig. 4, 5 and 6.

2. if standard NICE photocells are used, functioning with at least one other pair of photocells is guaranteed
3. if photocells are used that are not produced by NICE, functioning may not be guaranteed.

In any case, to check that there are no effects caused by other devices, carefully perform the testing procedure indicated in chapter 4 and check the related signals in table 4.

- Two FT210B devices cannot be positioned to cover the same area. If a receiver were to detect the signals of two transmitters, it would switch to the “safety” mode preventing the movement of the gate. See the specific signal in table 4.
- Two FT210B devices can be positioned to cover the front (FT A) and back (FT B) of the same gate, as illustrated in figure 3.
- Two sensitive edges can be fitted, front and back (FT C), to a gate with a single FT210B device, which are connected together in cascade as described in chapter 3.1.1.1. In this case the FT210B device can be used both as a presence detector, by positioning the transmitter and receiver as illustrated in figure 4, or as a simple detector of the sensitive edge status, by positioning the transmitter and receiver as illustrated in figure 5.
- In the case of gates set opposite one another and synchronised in the master-slave mode (with Robus or Run), two FT210B devices (FT B and FT C) can be positioned as illustrated in figure 6. A single sensitive edge can be fitted on each gate or 2 sensitive edges (front and back) that are connected together in cascade as described in chapter 3.1.1.

In all the cases indicated in figures 3, 4, 5 and 6, a JPX jumper must be placed on the receiver (see table 3) in order to obtain the function (FT A; FT B or FT C) as illustrated in the related figures.

3

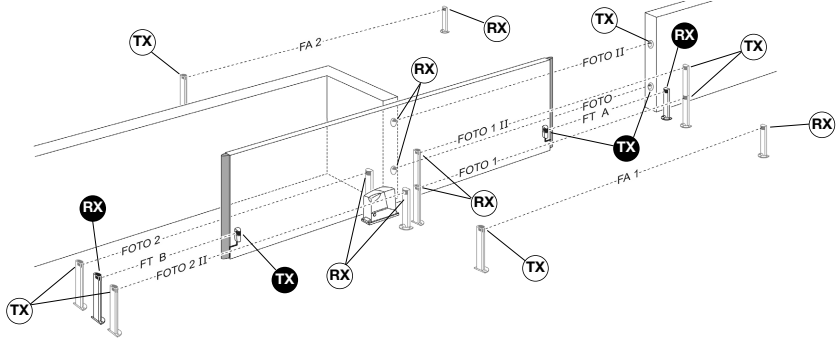

4

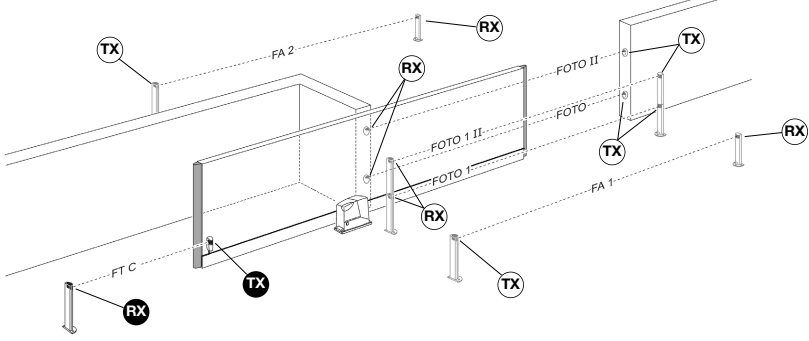

5

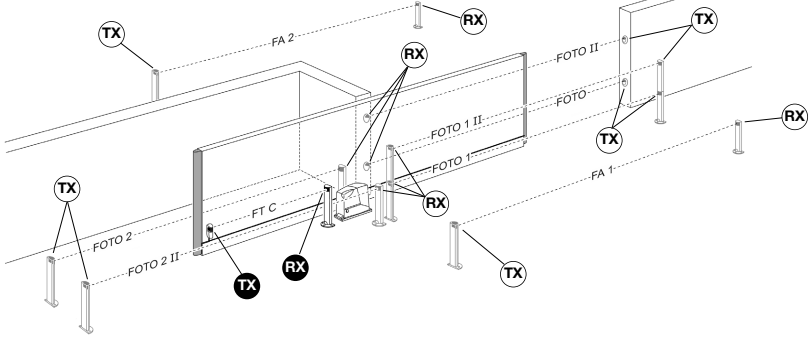

6

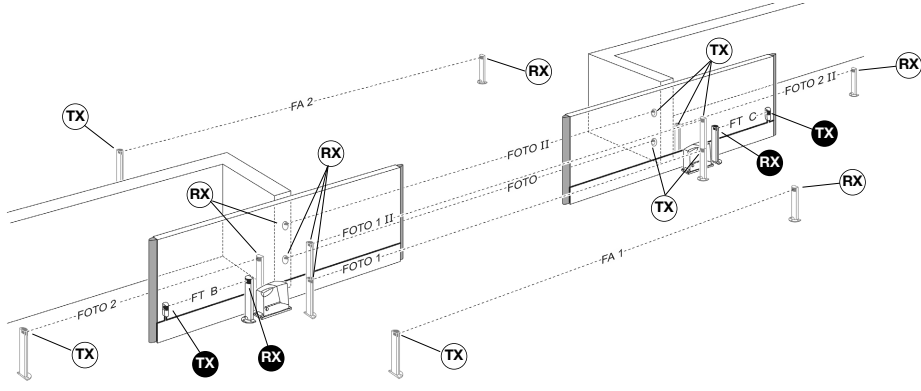

- The FT210B TX transmitter emits a beam with an angle of approximately  $\pm 4^\circ$ , therefore a perfect alignment between TX and RX is necessary that remains intact throughout the entire movement of the gate.

Figure 7 illustrates an example of correct assembly; figure 8 illustrates two examples of incorrect assembly.

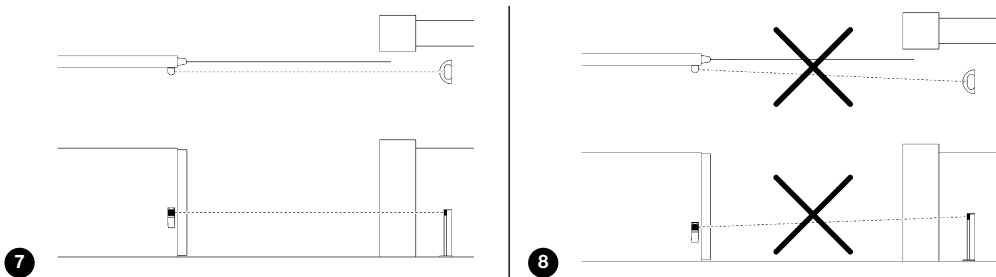

- If necessary, the receiver can be fitted on a special MOCF post with related FA2 accessories (see figure 9), or fixed to the wall. If the receiver is fixed to the wall the cables can arrive from the base (see figure 10) or below, in which case it is necessary to use "PG9" type cable clip (see figure 11).

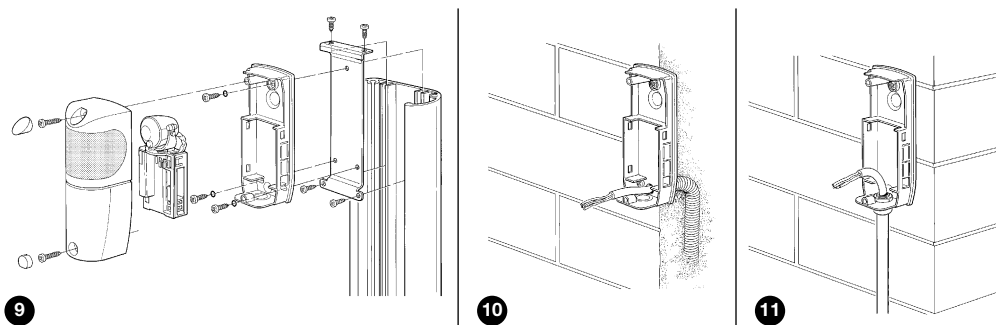

**Table 1: cables list**

Connection	Cable type	Max. length	Description
TX: sensitive edge input	2x0,5mm <sup>2</sup>	20m	Sensitive edge status reading input
RX: "BlueBUS"	2x0,5mm <sup>2</sup>	30m	Connection of the receiver to the "BlueBUS" network of the control unit

### 3.1.1) Connection of 2 or more sensitive edges

The FT210B has only one sensitive edge input, but 2 or more sensitive edges that perform the same function can be cascade connected one after the other as in figure 12 applying a single 8.2K $\Omega$  termination resistance.

**Warning:** the constant resistance devices must be cascade connected and never in series or parallel to one another!

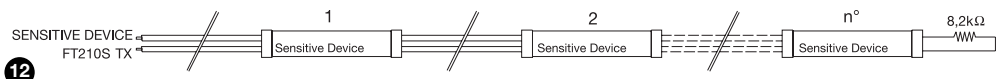

### 3.2) Fixing of the devices

Perform the installation and fixing of the devices following the operations below:

1. To separate the electronic board from the base, use a screwdriver to lever the three clips as indicated in fig. 13.
2. Fix the receiver as shown in fig. 14.
3. Assemble the transmitter on the mobile leaf as shown in figure 15.

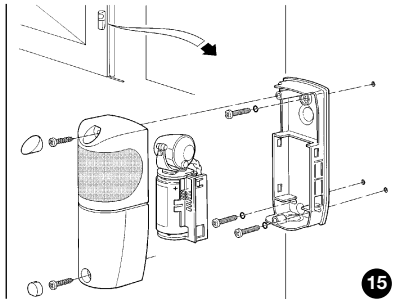
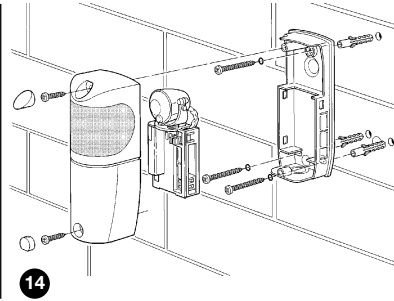
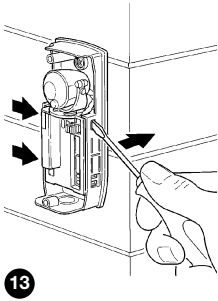

4. Connect the 8.2KΩ constant resistance type sensitive edge on the transmitter as shown in figure 16. The resistance on the TX terminals is removed and used as a termination on the sensitive edge or does not need to be used if the sensitive edge already has a terminating resistance.

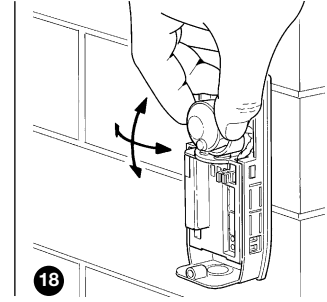
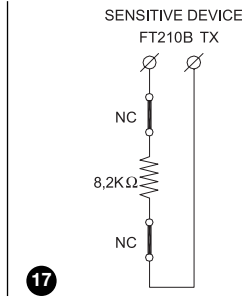
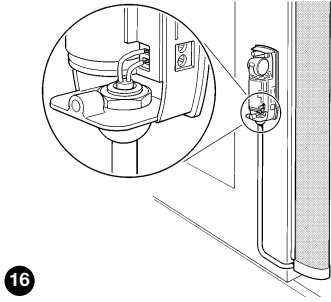

If the sensitive edge has an output with 2 separate NC contacts, it can be connected as shown in figure 17 placing the 8.2KΩ resistance in series between the two contacts. Make sure that the sensitive edge complies with the failsafe category 3 according to the EN 954-1 standard.

**Warning:** do not use sensitive edges that have only one NC type contact because they do not have the necessary failsafe category required by the said standard.

5. Carry out the "BlueBUS" electrical connections on the receiver following that which is indicated in the control unit instructions manual.
6. Direct the lenses as in fig. 18 in order to obtain the correct alignment between the TX and RX. The correct alignment will be verified in chapter 4 "Testing".
7. Program the jumpers on both the TX and RX (see paragraph 19) for the desired function following that indicated in tables 2 and 3.

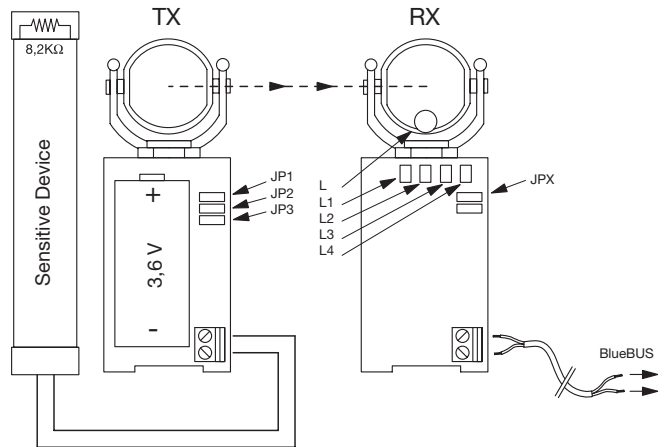

**Table 2: TX transmitter jumpers**

Jumper	Position	Description
JP1	Connected	Transmitter power suitable for gates up to 15 meters
	Disconnected	Transmitter power suitable for gates up to 7 meters
JP2	Connected	Change over to SLOW transmission after 10 seconds from the end of the manoeuvre (see JP3). (Advised in order to prolong the life of the battery)
	Disconnected	Change over to SLOW transmission after 90 seconds from the end of the manoeuvre (see JP3). (Advised when "refresh pause time", "close immediately after photo" etc type functions are used)
JP3	Connected	Change over to SLOW transmission at the end of the manoeuvre (Advised in order to prolong the life of the battery)
	Disconnected	Never changes over to SLOW transmission but remains in the FAST mode (Advised for gates without vibrations)

**Table 3: RX receiver jumpers**

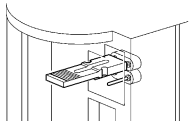
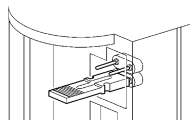
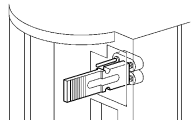
Photocell	Functions performed	Jumpers
<b>FT A</b> 1 <sup>st</sup> gap	<ul style="list-style-type: none"> <li>The cutting in of the sensitive edge causes a brief inversion and halt of the movement both in the opening and closing manoeuvre</li> <li>The interruption of the infrared beam during the closing manoeuvre causes the movement to invert; no effect occurs during the opening manoeuvre</li> </ul>	
<b>FT B</b> secondary gap	<ul style="list-style-type: none"> <li>The cutting in of the sensitive edge causes a brief inversion and halt of the movement both in the opening and closing manoeuvre</li> <li>The interruption of the infrared beam during the opening manoeuvre causes the movement to invert; no effect occurs during the closing manoeuvre</li> </ul> <p><b>Warning: SEE NOTE 1</b></p>	
<b>FT C</b> secondary gap	<ul style="list-style-type: none"> <li>The cutting in of the sensitive edge causes a brief inversion and halt of the movement both in the opening and closing manoeuvre</li> <li>If the infrared beam is broken, both during opening and during closing, a slight inversion is caused and the movement is stopped.</li> </ul> <p><b>Warning: SEE NOTE 2</b></p>	

**NOTA 1:** The FT B can also be used on double gates in master-slave mode (see figure 6). In this case the FT B acts in the same way as the FT C: the activation of the sensitive edge or breaking of the infrared beam, both during opening and during closing, causes a slight inversion and the movement to stop.

**NOTA 2:** The FT C can also be used on single gates (see figures 4 and 5) where two sensitive edges are used on the front and back.

8. Place the jumpers that have not been used in the specific location for future use (see figures 20 and 21).

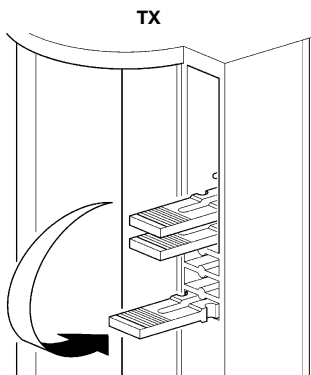

20

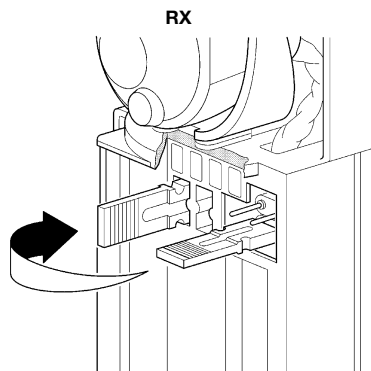

21

## 4) Testing

Each individual component of the automation system requires a specific testing phase. Perform the following sequence of operations for the testing of the FT210B. If there are two FT210B devices (see figures 3 and 4), the sequence is repeated for each device.

**Warning:** some points require that the gate is in movement for the control; as the automation MAY not be adequately SAFE, the maximum attention must be given during these controls.

1. Make sure that all that is foreseen in the present manual, in particular chapters 1 "Warnings" and 3 "Installation" is fully abided by.
2. Release and fully open the gate leaf so that the TX is at the maximum possible distance from the RX.
3. Make sure that there are no obstacles between the TX and the RX.
4. If already connected, disconnect the receiver from the "BlueBUS" and remove the battery from the transmitter.
5. Disconnect the sensitive device from the TX terminals and measure the resistance of the device with an ohmmeter, checking that the value is between 7700Ω and 8700Ω (nominal 8200Ω).
6. Push the sensitive edge to activate it and measure once again the resistance. Check that the resistance is lower than 1000Ω or higher than 16500Ω.
7. Reconnect the sensitive device to the TX terminals
8. Reconnect the receiver to the "BlueBUS" and perform the recognition of the devices connected to the "BlueBUS" from the control unit.
9. Check that the L1 (Ir Level) L2 (Phototest Ko) and L3 (Sensitive Device Ko) LEDs are on. Check that the L4 LED (Sensitive Device Ok) is off (see figure 23).
10. Remove the JP3 jumper on the TX so that it always transmits in the FAST mode.
11. If the distance between the TX and the RX exceeds 7m check that the JP1 jumper on the TX is connected (this meaning programmed for distances up to 15m).
12. Insert the FTA1 or FTA2 battery into the TX (see figure 29 or 30).
13. Check that the L1 (Ir level) LED on the RX receiver flashes; the L2 (Phototest Ko) LED and the L4 (Sensitive device Ok) LEDs are on and that the L3 (Sensitive device Ko) LED is off.
14. If necessary, improve the alignment by directing the TX and RX lenses as shown in figure 18. By performing the L1 (Ir level) L1D signal the speed of the flashing is less and the alignment is greater. The adjustment is at its best when the L1 LED flashes slowly at a maximum of 3 flashes a second.
15. Repeat the test by placing the upper protective shells both on the TX as well as on the RX. Remember that the RX shell has an attenuator filter that simulates the adverse weather conditions that may occur during use.
16. Move the gate leaf along the entire movement and check, through the flashes of the L1 LED, that the alignment remains above the optimum.
17. To check the optical presence sensor (type D) of the FT210B, and to make sure that there is no interference with other devices, pass a 50 mm diameter cylinder across the optical axis, first near the TX, then near the RX and finally between the two (see figure 22) and make sure that in all cases the device is triggered, switching from the active status to the alarm status (LED L1 ON) and vice versa;
18. To check the PSPE pressure sensitive device of the FT210B, push and release the sensitive edge as shown in figure 23 and check that the L4 LED turns off and that the L3 LED turns on and vice versa.
19. If this is the preferred program, connect the JP3 jumper on the TX so that the transmission changes over to SLOW a few seconds after the movement has finished.
20. If the operation in the previous point has been performed; check that the transmitter changes over to SLOW after the foreseen time has past (see JP2 in table 2). The transmission in the SLOW mode can be recognised through four short flashes of the L1 LED followed by a pause.

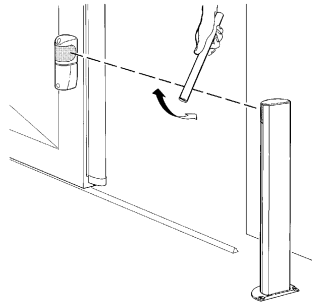

22

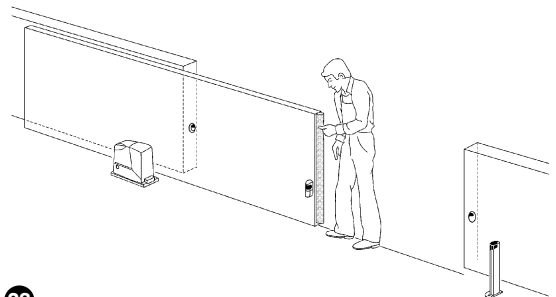

23



21. Mechanically connect the leaf to the motor and perform a manoeuvre of the gate. In the meantime, check that the L2 LED turns off at the beginning of the manoeuvre, indicating that the vibration sensor test of the moving gate has been performed correctly.

22. Perform various gate manoeuvres and check that the opening and closing are correctly performed without the inversion of the movement.

23. Perform further manoeuvres and activate the optical presence detector, as illustrated in point 17, during the closing manoeuvre (if "FT A" function) or the opening manoeuvre (if "FT B" function) or both (if "FT C" function) and ensure that a short inversion occurs and the movement stops.

24. Perform additional manoeuvres and during the closure activate the sensitive edge as indicated in point 18 and check that the foreseen action is performed such as the inversion of the movement.

25. The control of the FT210B optical presence sensor (type D) according to the EN 12445 standard, is performed with the 700x300x200mm test parallelepiped with 3 opaque black faces and 3 polished white or mirrored faces as indicated in figure 24 and according to chapter 7 of the EN 12445:2000 standard (or enclosure A of prEN12445:2005).

26. The control of the PSPE pressure sensitive device of the FT210B according to the EN 12445 standard, is performed by measuring the force at the points foreseen in chapter 5 of the EN 12445 standard, if the hazardous situations, which have been caused by the movement of the leaf have been safeguarded through the limitation of the impact force (type C).

27. After having checked all the previous points, remove the attenuator filter from the glass of the RX receiver as illustrated in figure 25.

28. Make sure that all casings of the various devices are closed when testing is complete.

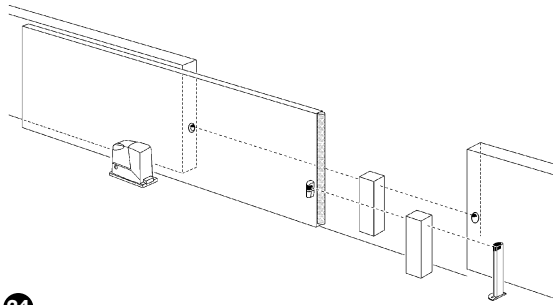

24

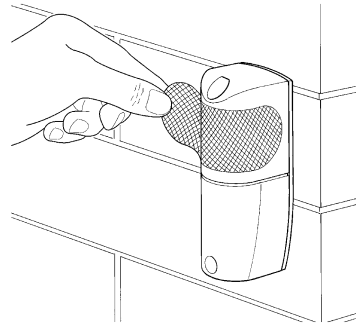

25

## 5) Additional information

Personalisation and how to look for and deal with faults on the FT210B will be dealt with in this chapter.

### 5.1) Example of the FT210B used as a presence detector only

The FT210B can be used as a simple type D presence sensor (photocell) without having to connect to the sensitive edge. In this case it is necessary to:

1. Perform the assembly as indicated in paragraph "Installation" without connecting the sensitive edge and leaving the 8200Ω resistance connected to the TX input.
2. Insert the "JP3" jumper of the transmitter so that the transmissions are always in the FAST mode.
3. Address the receiver jumpers based on the area of the gate where the FT210B is to be placed (figure 3) and following table 3

**Note:** The FAST transmission mode reduces the battery life of the transmitter. In this case the estimated life of a C type battery (FTA1 kit) is as follows:

- approximately 24 months for gates up to 7m (JP1 jumper of the TX disconnected)
- approximately 18 months for gates up to 15m (JP1 jumper of the TX connected)

**5.2) Example of the FT210B used as a presence detector only**

In the event that the FT210B is used as a sensitive edge status detector only, therefore without the presence detector function, the photo device should be installed as illustrated in figures 5 and 6.

In this case it is necessary to:

1. Perform the assembly as illustrated in the "Installation" paragraph.
2. Set the jumpers on the TX as required, see Table 2.
3. Set the JPX jumper on the RX (see Table 3) in order to obtain the "FT B" or "FT C" functions illustrated in the figure.

**5.3) Signals**

The FT210B receiver has various LED signals (see figure 26) that give luminous signals based on the operational status.

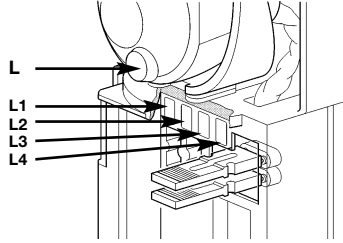

26

Table 4: Signal		
LED L (red)	Cause	Action
2 short flashes Pause 2 short flashes	TX flat battery signal	Replace the transmitter battery as soon as possible with another of the same type
Led L1 (red) IR Level	Cause	Action
Regular flash	The rate of the flash indicates the quality of the reception: the slower the flash the greater the reception.	Everything Ok if the flash is slow: maximum 3 per second, otherwise the alignment of the TX and RX must be checked
On	The receiver does not receive any infrared signals from the TX	Remove the obstacle or improve the TX and RX alignment
2 short flashes pause 2 short flashes	Incorrectly function device	The FT210B photo device has an improper function. Set the receiver jumper correctly as illustrated in table 3
3 short flashes pause 3 short flashes	The control unit does not recognise the device	Repeat the recognition procedure from the control unit. Make sure that all FT210B photo devices have different functions.
4 short flashes pause 4 short flashes	The transmitter is in the SLOW mode	Everything Ok if the gate is not moving
5 short flashes pause 5 short flashes	The receiver receives interference from unrecognisable infrared signals	An unknown transmitter is sending a signal towards the receiver, try to remove the interference; check the alignment of all devices present
7 short flashes pause 7 short flashes	The receiver receives the infrared signal from a second FT210B transmitter	Eliminate the second transmitter. Two FT210B transmitters cannot be positioned in the same area.
Led L2 (yellow) Fototest KO	Cause	Action
On	Signals an error during the test at the beginning of the manoeuvre and the transmitter is not changed over to the FAST mode	Possible poor functioning of the movement sensor
Off	The test at the beginning of the last manoeuvre was correct	Everything Ok
Led L3 (red) Sensitive Device KO	Cause	Action
On	The sensitive edge that is connected to the transmitter is active	Check the reason the edge was activated
Off	The sensitive edge connected to the transmitter is not active	Everything Ok
Led L4 (green) Sensitive Device OK	Cause	Action
On	The sensitive edge connected to the transmitter is not active	Everything Ok
Off	The sensitive edge that is connected to the transmitter is active	Check the reason the edge was activated

### 5.3) Troubleshooting

Table 5 gives possible indications on how to deal with malfunctions that may be met during installation or due to a fault.

Table 5: Fault diagnostics	
Symptoms	Advisable checks
The gate cannot be controlled; all the LEDs on the FT210B receiver are off	Check if the receiver is correctly connected to the "Blue-BUS"
The gates starts to move but stops after 1 second; LED 2 (yellow) is on	The outcome of the test at the beginning of the manoeuvre was negative and there is a possible fault in the TX movement sensor of the gate
The gate stops during the manoeuvre or the manoeuvre is inverted; the LED L1 (red) is constantly on	Check for possible obstacles or the alignment of the TX and RX through the entire movement of the gate
The gate stops during the movement or the manoeuvre is inverted; the LED L3 (red) is on and the LED L4 (green) is off.	The sensitive edge has cut-in. Remove the possible obstacle or check that the sensitive edge is working correctly
Sometimes the gate stops during the movement or the manoeuvre is inverted; the LED L1 flashes rapidly when the gate is open	Check the alignment between the TX and RX throughout the entire movement of the gate
Sometimes the gate stops during the movement or the manoeuvre is inverted; sometimes it blocks completely and cannot be controlled; the LED L (red) continues to make 2 short flashes	The TX battery is flat and communication between the TX and RX does not occur when conditions are poor. The flashing LED L (red) indicates that the battery needs changing

## 6) Maintenance

The FT210B does not require any particular maintenance, however a control should be performed at least once every six months to check the integrity of photocells FT210B (presence of dampness, rust, etc), cleaning of the external casing and testing as described in chapter 4 "Testing". FT210B photocells have been designed to function under normal conditions for at least 10 years, therefore maintenance should be performed more frequently once this period has expired.

Replace the transmitter battery if the voltage of the battery is lower than 2.7V immediately after a complete manoeuvre (when the transmission is in the FAST mode).

## 7) Disposal

As for the installation, the disposal of the product at the end of its effective life, must be performed by qualified personnel.

This product is made of various types of material, some of which can be recycled while others must be disposed of. Enquire about the recycling or disposal systems available for this product category in compliance with regulations locally in force.

**Warning:** some parts of the product may contain polluting or hazardous substances that, if incorrectly disposed of, could have a damaging effect on the environment or on the health of individuals.

As indicated by the symbol in figure 27, this product must not be disposed of in household waste. Perform "separated collection" for disposal in compliance with regulations locally in force, or return the product to the manufacturer when purchasing a replacement.

Heavy fines may be imposed by local laws for the illegal disposal of this product.

**Warning:** the product operates with batteries that could contain polluting substances and therefore should not be disposed of along with household waste. After they have been removed from the product (see paragraph "Battery replacement" in chapter "FT210B installation instructions and warnings") they should be disposed of in compliance with the legislations locally in force.



## 8) Accessories

The following accessories are available:

- FA1: metal vandal-proof casing, fitted as in fig. 28
- FA2: fixing brackets for "MOCF" posts, fitted as in fig. 29
- FTA1: 3.6V battery; 7Ah type C, fitted as in figure 30
- FTA2: 3.6V battery; 2Ah type AA, fitted as in figure 31

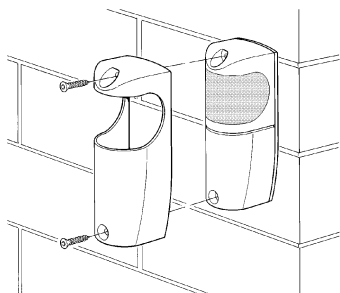

28

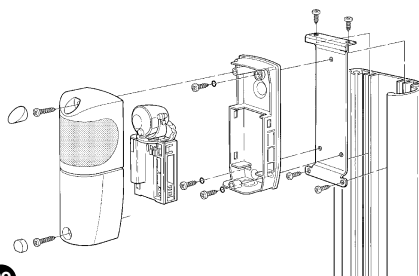

29

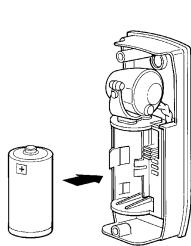

30

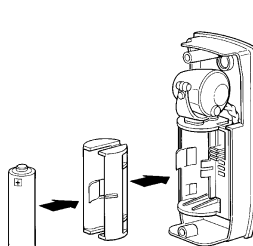

31

## 9) Technical characteristics

In order to improve its products, NICE S.p.a. reserves the right to modify the technical characteristics at any time without prior notice. In any case, the manufacturer guarantees their functionality and fitness for the intended purposes. Note: all technical characteristics refer to a temperature of 20°C.

FT210B technical characteristics	
Product Type	Device for the optical status transmission of a constant resistance sensitive edge positioned on the moving part, comprising a battery powered infrared transmitter (TX) that is positioned on the moving leaf, to which the sensitive edge is connected, and a receiver (RX) positioned on the fixed part.
Adopted technology	TX-RX direct optical interpolation with modulated and coded infrared beam
Receiver power supply	The device can only be connected to "BlueBus" networks from which it is powered and sends the output signals.
Receiver absorbed power	0.5 Blue bus unit
Transmitter power supply	3.6V with type C or AA lithium battery
Transmitter battery life (with JP3 on)	Estimated at approx. 15 years with the type C battery, 7Ah capacity; ("residential" use: TX-RX distance up to 7m; with 20 manoeuvres per day of 90°) Estimated at approx. 5.5 years with the type C battery, 7Ah capacity; ("industrial" use: TX-RX distance up to 15m; with 200 manoeuvres per day of 90°) Estimated at approx. 6 years with the type AA battery, 2Ah capacity; ("residential" use: TX-RX distance up to 7m; with 20 manoeuvres per day of 90°)
Device input range Sensitive (Rs)	Typical 8.2KΩ; +22%/-65% for the on status (ON) ON limits: with Rs > 2.870 and Rs < 10.010. OFF limits: with Rs < 2.590. or Rs > 11.060.
Type D presence sensor detection capacity	Opaque objects located on the optical axis between TX and RX, larger than 50 mm and moving slower than 1.6m/s
TX transmission angle	+/- 4° (value taken at 50% of the capacity)
RX reception angle	+/- 3° (value taken at 50% of the capacity)
Directional capacity	approx. 210° on the horizontal axis and 30° on the vertical axis
Useful range	7m or 15m (with JP1 inserted on TX) for maximum TX-RX misalignment ± 2° (the range may be further reduced in the presence of particularly intense atmospheric conditions: fog, rain, snow, dust, etc.)
Maximum range (under optimum conditions)	15m or 30m (with JP1 inserted on TX) for maximum TX-RX misalignment ± 2°
Presence sensor response time	< 96ms (typical 65ms) with 1 pair of MOFB photocells connected together with the FT210B
Sensitive edge response time	< 64ms (typical 50ms)
Failsafe category	3 (according to the EN 954-1 standard)
Use in acid, saline or potentially explosive atmosphere	No
Assembly	RX: vertically wall mounted or on "MOCF" posts with "FA2" bracket TX: directly on the gate with the supplied screws
Protection class casing	IP44
Operating temperature	-20 ÷ 55°C
Dimensions	46 x 128 h 45mm
Weight	Receiver: 135g. transmitter 165g with FTA1 or 140g with FTA2

# FT210B installation instructions and warnings



GB

These instructions can be incorporated with the "Instructions and warnings for the use of the automation" which the installer must give the owner of the automation, and must be incorporated by them.

- **Maintenance:** Like any machine, your automation needs regular periodic maintenance to ensure its long life and total safety. Arrange a periodic maintenance schedule with your installation technician. Nice recommends that maintenance checks should be carried out every six months for normal domestic use, but this interval may vary depending on the intensity of use. Only qualified personnel are authorized to carry out checks, maintenance operations and repairs.
- Do not modify the system or its programming and adjustment parameters in any way, even if you feel capable of doing it: your installation technician is responsible for the system.
- The final test, the periodic maintenance operations and any repairs must be documented by the person who has performed them; these documents must remain under the custody of the owner of the system.
- The only recommended maintenance operations that the user can perform periodically concern the cleaning of the photocell glasses and the removal of leaves and debris that may impede the automation. To prevent anyone from activating the gate, release the automation system and use a slightly damp cloth to clean.
- **Disposal:** At the end of its useful life, the automation must be dismantled by qualified personnel, and the materials must be recycled or disposed of in compliance with the legislation locally in force.

### Replacement of the FT210B transmitter battery

The transmitter on the mobile leaf of the gate has a special 3.6V lithium battery that, depending on the use conditions, has an estimated life of various years. A signal is given a few months before the battery is completely flat in order to give ample time for replacement.

It is time to change the battery if the **receiver** on the fixed section (on the wall as in figure A or on the post as in figure B) gives the following signal: **2 short flashes followed by a 1 second pause.**

The battery is housed in the **transmitter** on the gate leaf; for replacement:

- 1) Remove the screw caps as in figure C
- 2) Unscrew the screws that hold the cover and remove it as in figure C
- 3) Use a screwdriver to lever out the flat battery
- 4) Wait about 10 seconds before introducing the new battery
- 5) Make sure the polarity is correct; the plus is at the top
- 6) Introduce the battery as in figure D or E depending on the type used
- 7) Secure the cover with the screws and replace the caps

**Warning:** the product operates with batteries that could contain polluting substances and therefore should not be disposed of along with household waste. After they have been removed from the product (see paragraph "Battery replacement" in chapter "FT210B installation instructions and warnings") they should be disposed of in compliance with the legislations locally in force.



There are 2 types of battery:

- **FTA1:** 3.6V battery; 7Ah type C, fitted as in figure D
- **FTA2:** 3.6V battery; 2Ah type AA, fitted as in figure E

**Caution: batteries used in this product are not normal alkaline versions.**

**Contact Nice s.p.a. to request the spare battery kits "FTA1" or "FTA2".**

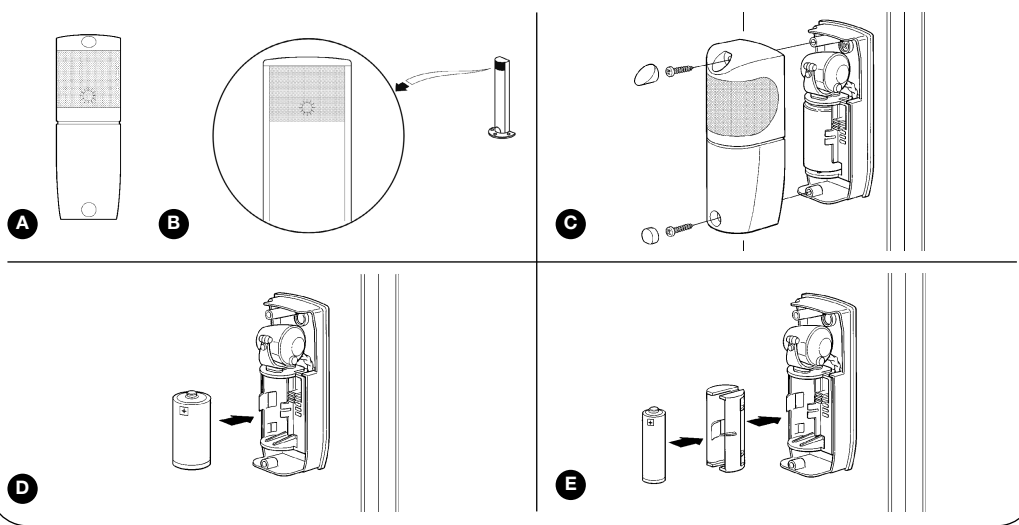

# Dichiarazione CE di conformità / EC Declaration of conformity

(Secondo la Direttiva 89/336/CEE) / (According to Directive 89/336/EEC)

**Numero / Number:** 221/FT210

**Revisione / Revision:** 1

**Nota:** il contenuto di questa dichiarazione di conformità corrisponde all'ultima revisione aggiornata alla data di edizione del presente documento; eventualmente riadattato per motivi editoriali. La versione integrale ed aggiornata della presente dichiarazione è depositata presso la sede di Nice S.p.a.

**Note:** *The content of the present declaration corresponds to the latest available revision, - before the printing of the present manual, - of the document registered at the head offices of Nice S.p.a. The original text of this manual has been readapted for publishing reasons.*

**Il sottoscritto Lauro Buoro, Amministratore Delegato, dichiara che il prodotto:  
The undersigned Lauro Buoro, General Manager, declares that the product:**

**Nome produttore / Name of product:**

NICE S.p.a.

**Indirizzo / Address:**

Via Pezza Alta 13, 31046 Z.I. Rustignè - ODERZO - ITALY

**Tipo / Type:**

Fotodispositivo orientabile / *Adjustable optical device*

**Modello / Model**

FT210B

**Accessori / Accessories:**

Box metallico antivandalico FA1, Kit batteria FTA1, Kit batteria FTA2

*Antivandal metallic box, battery kit FTA1, battery kit FTA2*

**Risulta conforme a quanto previsto dalle seguenti direttive comunitarie, così come modificate dalla Direttiva 93/68/CEE del consiglio del 22 Luglio 1993:**

**Complies with the following community directives, as modified from Directive 93/68/EEC of the Council of the 22 July 1993.**

89/336/CEE: Direttiva 89/336/CEE del Consiglio del 3 maggio 1989 per il riavvicinamento delle legislazioni degli Stati membri relative alla compatibilità elettromagnetica.

89/336/CEE: *(Council Directive of 3 May 1989 on the approximation of the laws of the Member States relating to Electromagnetic Compatibility).*

Secondo le seguenti norme: EN 61000-6-2:2001; EN 61000-6-3:2001+A1:2004

*Complies with the following standards: EN 61000-6-2:2001; EN 61000-6-3:2001+A1:2004*

Inoltre soddisfa totalmente o parzialmente per le parti applicabili, i requisiti delle seguenti norme:

EN 13241-1:2004, EN 12453:2002, EN 12445:2002, EN 12978:2005, EN 61496-1:2004, IEC EN 61496-2:1997

*Also satisfies totally or partially for the applicable parts, the requirements of the following standards:*

EN 13241-1:2004, EN 12453:2002, EN 12445:2002, EN 12978:2005, EN 61496-1:2004, IEC EN 61496-2:1997

Oderzo, 11 Aprile 2006

  
Lauro Buoro  
(Amministratore Delegato)  
(Managing Director)







COMPANY  
WITH QUALITY SYSTEM  
CERTIFIED BY DNV  
=ISO 9001/2000=

#### Headquarter

##### Nice SpA

Oderzo TV Italia  
Tel. +39.0422.85.38.38  
Fax +39.0422.85.35.85  
info@niceforyou.com

##### Nice in Italy

##### Nice Padova

Sarmeola di Rubano PD Italia  
Tel. +39.049.89.78.93.2  
Fax +39.049.89.73.85.2  
infopd@niceforyou.com

##### Nice Roma

Roma Italia  
Tel. +39.06.72.67.17.61  
Fax +39.06.72.67.55.20  
inforoma@niceforyou.com

#### Nice worldwide

##### Nice France

Buchelay  
Tel. +33.(0)1.30.33.95.95  
Fax +33.(0)1.30.33.95.96  
info@fr.niceforyou.com

##### Nice Rhône-Alpes

Decines Charpieu France  
Tel. +33.(0)4.78.26.56.53  
Fax +33.(0)4.78.26.57.53  
infoyon@fr.niceforyou.com

##### Nice France Sud

Aubagne France  
Tel. +33.(0)4.42.62.42.52  
Fax +33.(0)4.42.62.42.50  
infomarseille@fr.niceforyou.com

##### Nice Belgium

Leuven (Heverlee)  
Tel. +32.(0)16.38.69.00  
Fax +32.(0)16.38.69.01  
info@be.niceforyou.com

##### Nice España Madrid

Tel. +34.9.16.16.33.00  
Fax +34.9.16.16.30.10  
info@es.niceforyou.com

##### Nice España Barcelona

Tel. +34.9.35.88.34.32  
Fax +34.9.35.88.42.49  
info@es.niceforyou.com

##### Nice Polska

Pruszków  
Tel. +48.22.728.33.22  
Fax +48.22.728.25.10  
info@pl.niceforyou.com

##### Nice UK

Chesterfield  
Tel. +44.87.07.55.30.10  
Fax +44.87.07.55.30.11  
info@uk.niceforyou.com

##### Nice Romania

Cluj Napoca  
Tel/Fax +40.264.45.31.27  
info@ro.niceforyou.com

##### Nice Deutschland

Gelnhausen-Hailer  
Tel. +49.60.51.91.52-0  
Fax +49.60.51.91.52-119  
info@de.niceforyou.com

##### Nice China

Shanghai  
Tel. +86.21.575.701.46  
+86.21.575.701.45  
Fax +86.21.575.701.44  
info@cn.niceforyou.com

##### Nice USA Inc.

Jacksonville, Fl.  
Tel. +001.904.786.7133  
Fax +001.904.786.7640  
info@us.niceforyou.com