

# optimus

4G LTE INTERCOMS

## 4G LTE RANGE OF INTERCOMS

### INSTALLATION MANUAL



DESIGNED AND  
MADE IN BRITAIN



Raising Standards  
Safety Assured



## CONTENTS

<b>INSTALLATION MANUAL FOR OPTIMUS 4G LTE RANGE OF INTERCOMS</b>	
Applicable Products	03
<b>GENERAL</b>	04
Overview	04
How it works	04
Product Description and Dimensions	04 – 05
<b>INSTALLATION AND CONNECTION</b>	06
Special Tools and Materials needed	06
What's Inside The Box	06
Positioning and Mounting the Intercom Unit	07
Surface Mounting	07
Siting of the Antenna	08
Cable Entry and Exit	08
Power Connection and Disconnection of the Optimus Range	08
Protective Earth and Bonding Terminals	09
<b>APPLICATIONS AND CONNECTIONS</b>	10
4G LTE I/O Board Connections	10
4G LTE PCB Connections	10
Applications Examples	11 – 14
Installing or Replacing the SIM Card	14
<b>PROGRAMMABLE SETTINGS VIA 'COMMTEL CONFIG' APP + ADDITIONAL MANUAL SMS COMMANDS</b>	15
Configurable Settings	15
<b>INTERNAL CELL REPLACEMENT FOR REAL TIME CLOCK (RTC)</b>	16
Replacing the Lithium Cell	16
<b>EU CE DECLARATION OF CONFORMITY AND RADIO EQUIPMENT DIRECTIVE</b>	17

## APPLICABLE PRODUCTS

### APPLICABLE PRODUCTS

The Commtel 4G PRO PCB is used in the following products:

#### OPTIMUS 4G LTE RANGE OF INTERCOMS

This Installation manual applies to these products.

## OVERVIEW

The Optimus 4G intercoms are entry systems which are suitable for any door, gate or barrier requiring communication and control over access. They can be used in any environment, internally or externally, including Domestic, Commercial and Public sectors.

They can be used across any number of entry or exit points, from single dwellings through to a high-density block of flats or offices.

## HOW IT WORKS

### Visitor Entry



### Authorised Dial In

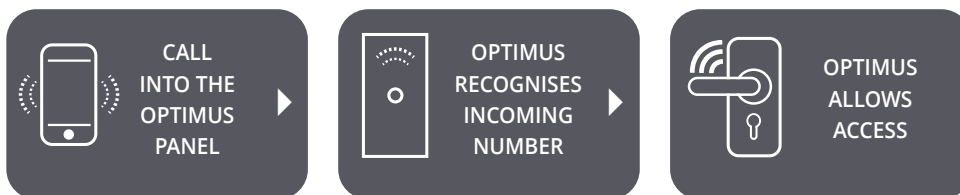

### Pin Code Entry

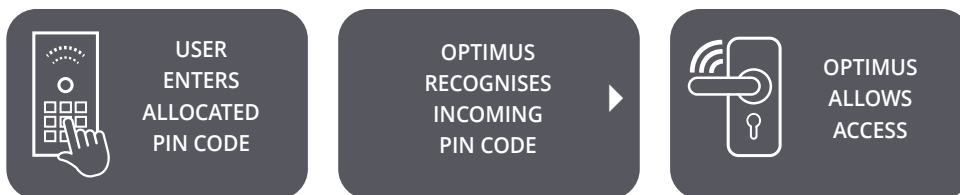

# GENERAL

## PRODUCT DESCRIPTION AND DIMENSIONS



**E1**

Max. Dimensions:  
H 224 x W 96 x D 40



**E1K**

Max. Dimensions:  
H 224 x W 96 x D 40



**E2K**

Max. Dimensions:  
H 224 x W 96 x D 40



**E3K**

Max. Dimensions:  
H 224 x W 96 x D 40



**E10K**

Max. Dimensions:  
H 224 x W 96 x D 40



**E100K**

Max. Dimensions:  
H 224 x W 96 x D 40



**E500K**

Max. Dimensions:  
H 224 x W 96 x D 40

	<b>E1</b>	<b>E1K</b>	<b>E2K</b>	<b>E3K</b>	<b>E10K</b>	<b>E100K</b>	<b>E500K</b>
NUMBER OF CALL POINTS	1	1	2	3	10	100	500
BACKLIT KEYPAD	-	✓	✓	✓	✓	✓	✓
INSTALLER PROGRAMMABLE	via App & SMS	via App & SMS	via App & SMS	via App & SMS	via App & SMS	via App & SMS	via App & SMS
SMS ALERTS	✓	✓	✓	✓	✓	✓	✓
RELAY OUTPUTS	3	3	3	3	3	3	3
AUX INPUT	2	2	2	2	2	2	2
ACCESS CODES	-	100	100	100	100	200	500
TIMED TRADE BUTTON	-	✓	✓	✓	✓	✓	✓
AUTHORISED DIAL TO OPEN	100	100	100	100	100	200	500
BACKBOX: Cast Alloy Powder Anthracite Grey	✓	✓	✓	✓	✓	✓	✓
FACEPLATE: Marine Grade Stainless Steel	✓	✓	✓	✓	✓	✓	✓

## INSTALLATION AND CONNECTION

### SPECIAL TOOLS AND MATERIALS NEEDED

1. 4G Analyser.
  - a. Recommendation:
 

Make ~ CSL
Model ~ CS2389 4G/LTE
RS Stock No. 176-2538
2. 2.5mm Hex Key.
3. Small Philips 00 Screwdriver.
4. Electronic Grade Silicone Sealant, *examples:*
  - a. American Sealants Inc 388
  - b. ACC Silicones AS1745G
  - c. Dow Corning 3145
5. Earthing wire minimum 1mm<sup>2</sup> – 18AWG – 30/0.2mm Green/Yellow.
6. M3 Crimp Ring Terminal.
7. Ground Earthing Spike (*if required*).

### WHAT'S INSIDE THE BOX

1. Optimus 4G LTE Intercom.
2. 4G Antenna.
3. Antenna Bracket.
4. Power Supply.
5. 20mm Gland.
6. 2.5mm Hex Screwdriver Bit.
7. Installation Guide.
8. End User / Customer Guide.
9. Mounting Template.
10. TG Telecom SIM Card Pack (*optional and subject to activation order*).

## INSTALLATION AND CONNECTION

### POSITIONING AND MOUNTING THE INTERCOM UNIT

The position of the Intercom Unit should maximise the safest and best operational performance and convenience, including:

1. Users considerations, with optimal height recommendations (*to centreline of the Intercom*):
  - a. Wheelchair: 750 – 1000mm.
  - b. Car: 200 – 1300mm.
  - c. Pedestrian: 1540 – 1550mm.
  - d. Lorry: 1700 – 1900mm.
2. Environmentally and neighbourhood friendly criteria avoiding:
  - a. Wind and rain.
  - b. Background noise.
  - c. Noise and light pollution from the Intercom Unit.
3. Minimising risk of vandalism.
4. Network and Signal strength measured with a 4G Analyser (*please see detailed instructions provided with the Analyser*).
5. Close proximity to a suitable switchable 13A AC power socket.

### SURFACE MOUNTING

Using the mounting template, the Intercom must be securely mounted and can be fitted to any secure location such as a post or on a smooth masonry constructed surface.

Feed the required cables carefully through the cable entry point in the rear of the Backbox and seal effectively against dust, insects and water ingress – see CABLE ENTRY AND EXIT section.

After mounting and before screwing in the Faceplate, the Backbox must be completely brushed out and be free of any drilling dust or metal filings. Please be aware that the speaker magnet may attract metal dust or filings which may impair its performance.

The Backbox mounting holes must be sealed against potential dust, insects and water ingress, using electronic grade silicone sealant, examples of this type of silicone are:

1. American Sealants Inc 388
2. ACC Silicones AS1745G
3. Dow Corning 3145

There are many other equivalent makes.

**DO NOT USE silicones with acetic acid (vinegar smell/bath sealant) as the fumes given off in a confined space can corrode delicate electronic parts.**

## INSTALLATION AND CONNECTION

### SITING OF THE ANTENNA

The supplied 4G antenna is an external item that should be installed in the most suitable position:

1. As high as possible and obtaining the maximum signal strength, checked by a 4G Analyser (*please see detailed instructions provided with the Analyser*).
2. Further than 200mm from a human body.
3. Minimising risks of vandalism.

### CABLE ENTRY AND EXIT

Ensure that Antenna, Power and other cable leads are looped before entering the back of the unit to minimise water ingress along the cables.

The cable entry hole in the back of the backbox is a threaded M20x1.5mm and is suitable for metal/plastic electrical conduit fittings.

The unit is supplied with a 20mm gland to allow wires to pass in and out of the back box where cables may have to travel a short distance to the control unit – we suggest once wiring is complete this gland is filled with electronic grade silicone sealant. *Examples of this type of silicone are:*

- |    |                       |         |
|----|-----------------------|---------|
| 1. | American Sealants Inc | 388     |
| 2. | ACC Silicones         | AS1745G |
| 3. | Dow Corning           | 3145    |

There are many other equivalent makes.

**DO NOT USE silicone's with acetic acid (vinegar smell/bath sealant) as the fumes given off in the confined space of the Backbox can corrode delicate electronic parts.**

If using metal/plastic conduit screwed into the backbox, the supplied gland may be discarded.

### POWER CONNECTION AND DISCONNECTION OF THE OPTIMUS RANGE

The Intercom is defined as Pluggable Equipment Type B fitted with a 3A fuse.

Power to the unit must be provided through connection to a locally accessible switched 13A Mains UK standard socket outlet.

The supplied Power Supply Unit is fitted with 1.5mtr lead and terminated with a UK standard 13A plug fitted with a 3A fuse.

Should it be necessary to disconnect power to the Intercom, this is done by switching off power at the mains switched socket that supplies the unit.



## INSTALLATION AND CONNECTION

### PROTECTIVE EARTH AND BONDING TERMINALS

The Intercom must be permanently earthed.

The Unit is fitted with an earth stud marked up with an earth label, the stud size is M3 and has a M3 Nyloc nut attached.

The earth wire must be at least 1mm<sup>2</sup> - 18AWG - 30/0.2mm Green/Yellow in accordance with normal electrical wiring standards.

This earth wire will be terminated with a crimped M3 ring terminal and fitted to the Earth Stud in the Backbox, the other end will be attached with similar method to the Mounting steel post, or via an Earth Ground Spike where the Intercom is mounted on a masonry surface.

# APPLICATIONS AND CONNECTIONS

## 4G LTE I/O BOARD CONNECTIONS

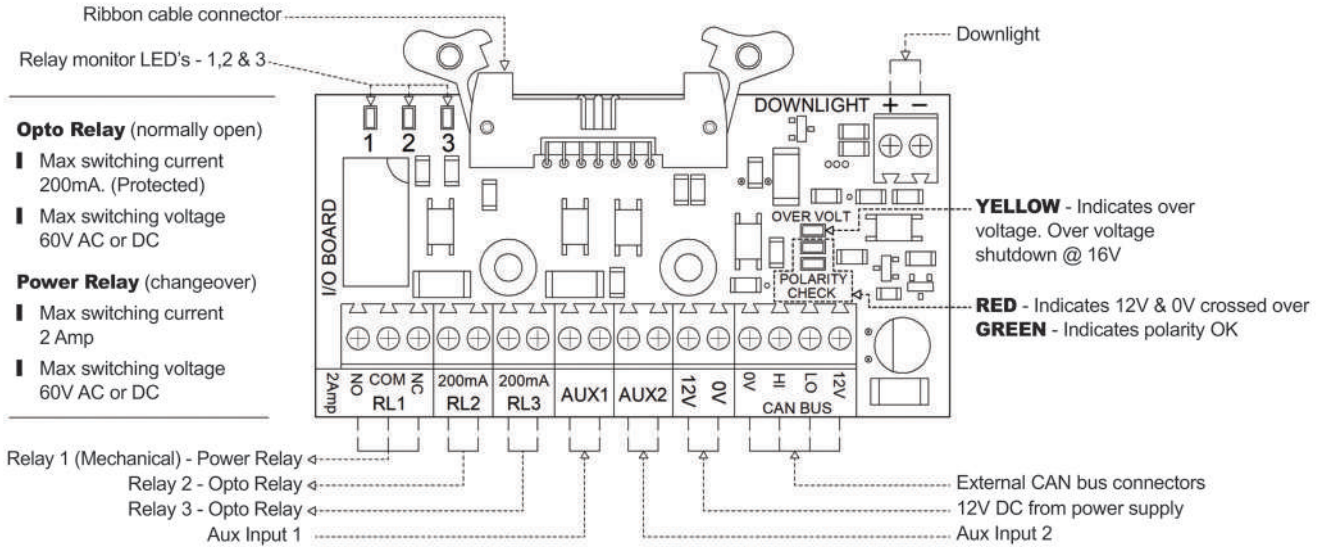

## 4G LTE PCB CONNECTIONS

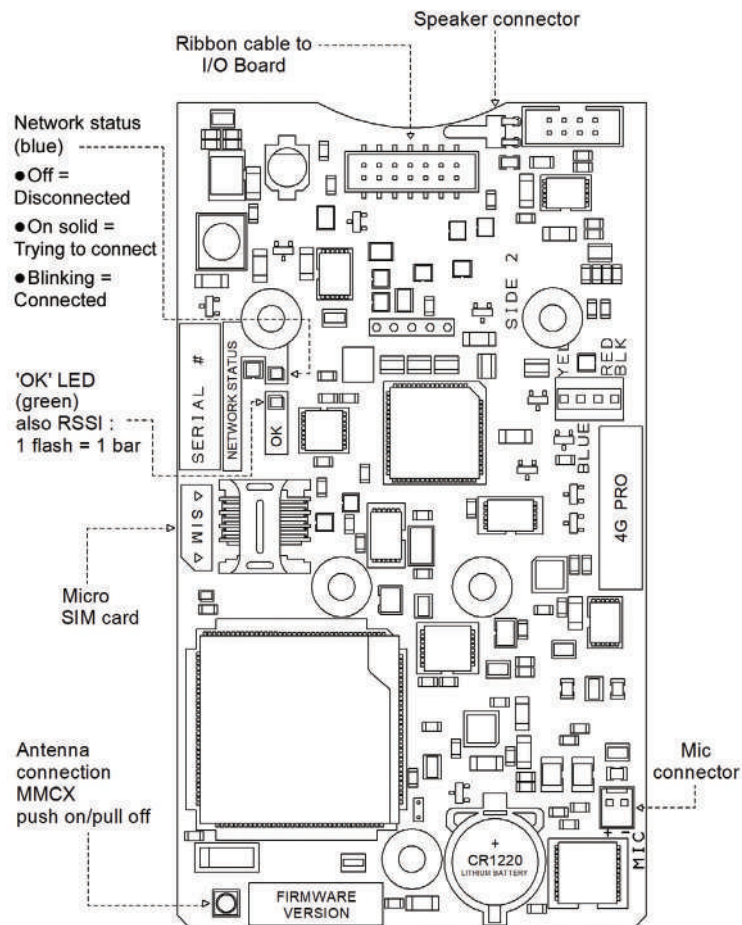

# APPLICATIONS AND CONNECTIONS

## APPLICATIONS EXAMPLES

Please see below some typical Application Examples:

*Example 1.0:* Optimus to Gate or Barriers System, where Controller requires a Simple Command to operate

*Example 2.0:* Optimus to Gate or Barrier System, where Controller requires a Constant Command for the duration of Hold or Stay Open

*Example 3.0:* Optimus to Gate or Barrier System, where Controller requires both Command and a Simultaneous Hold Open Switch

*Example 4.0:* Optimus to an Electric Lock or Latch Release where the Lock Power Supply Unit requires a Pulse to Release or Unlock

*Example 5.0:* Optimus to a Magnetic Lock or Permanently Energised Lock where the Lock Power Unit requires to be Un-Switched to Release the Lock ~ subject to Type and Failure Status

*Example 6.0:* Alternative Exit Control using Auxiliary Input. Auxiliary Input to activate Set Relay. e.g. Push to Exit

### EXAMPLE 1.0

**Application:** OPTIMUS TO GATE OR BARRIER SYSTEM

**Condition:** THE CONTROLLER REQUIRES A SIMPLE COMMAND TO OPERATE

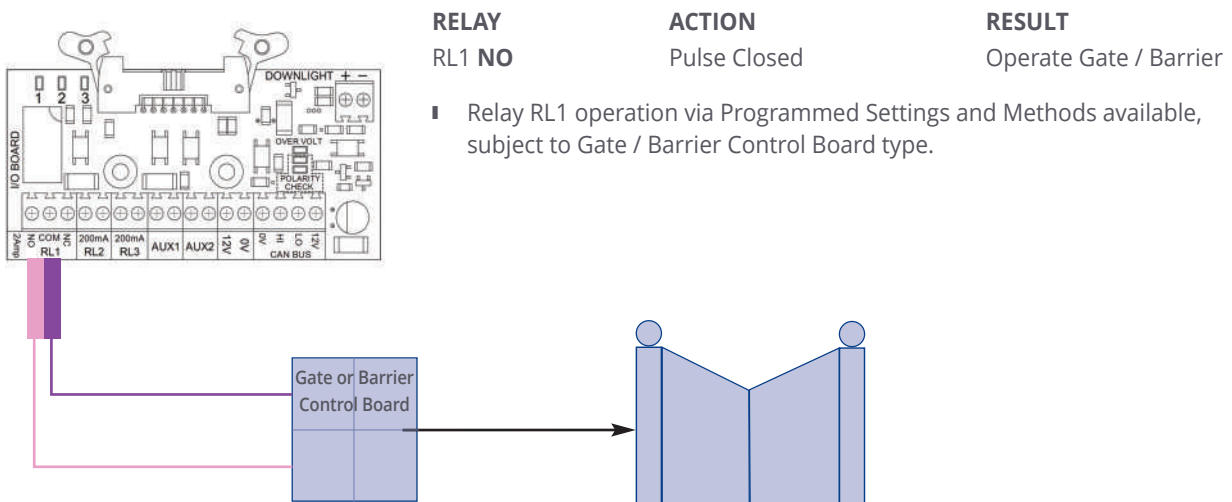

- Methods of Relay Operation can include: DTMF Tone / Facia PINS / Authorisation Recognition.
- Typical examples not common to all systems. Please follow the appropriate DHF Code of Practice accordingly.

## APPLICATIONS AND CONNECTION

### EXAMPLE 2.0

Application: **OPTIMUS TO GATE OR BARRIER SYSTEM**

Condition: **THE CONTROLLER REQUIRES A CONSTANT COMMAND FOR THE DURATION OF HOLD OR STAY OPEN**

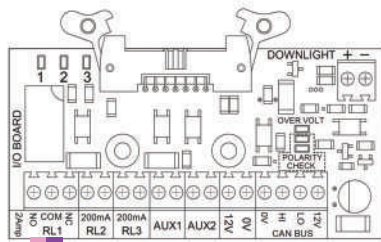

RELAY	COMMAND ACTION	RESULT
RL1 <b>NO</b>	Pulse Closed	Opens Gate
or		
RL1 <b>NO</b>	Switch Closed	Gate Stay Open
RL1 <b>NO</b>	Un-Switch	Stay Open released

- Relay RL1 operation via Programmed Settings and Methods available, subject to Gate / Barrier Control Board type.

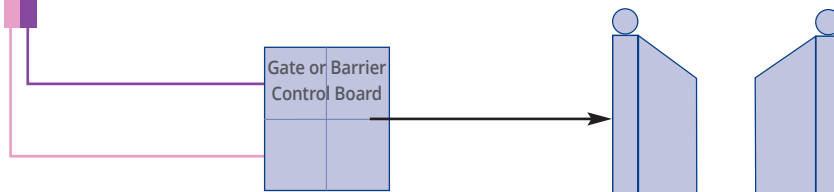

- Some Gate or Barrier Control Boards may require a command to Open as well as a Switch Stay Open Interface and some may only need the one. More than One Relay can be used, subject to Programmes Set Up and Default Settings.
- Methods of Relay Operation can include: DTMF Tone / Facia PINS / Authorisation Recognition.
- Typical examples not common to all systems. Please follow the DHF Code of Practice Guide accordingly.

### EXAMPLE 3.0

Application: **OPTIMUS TO GATE OR BARRIER SYSTEM**

Condition: **THE CONTROLLER REQUIRES BOTH COMMAND AND A SIMULTANEOUS HOLD OPEN SWITCH**

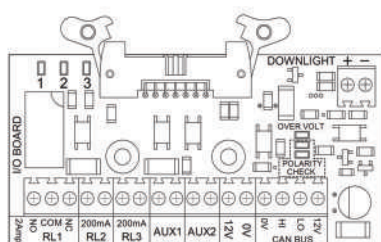

RELAY	ACTION	RESULT
RL1 <b>NO</b>	Pulse Closed	Opens Gate
+		
RL2 or RL3	Switched	Stay Open
RL2 or RL3	Un-Switch	Release Stay Open

- As RL2 and RL3 are Factory Set as **NO**, one of these may need re-programming to **NC** if used to break a Closed Safety Circuit or similar.
- Some Controllers Stay Open status may be **NC**. The Power Down status of reprogrammed Optimus Relay will need to be accounted for in the Installation Design.

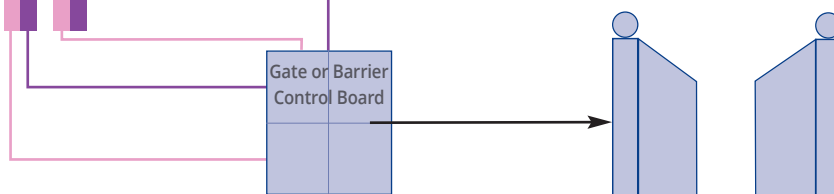

- Methods of Relay Operation can include: DTMF Tone / Facia PINS / Authorisation Recognition.
- Typical examples not common to all systems. Please follow the DHF Code of Practice Guide accordingly.

## APPLICATIONS AND CONNECTIONS

### EXAMPLE 4.0

**Application:** OPTIMUS TO AN ELECTRIC LOCK OR LATCH RELEASE

**Condition:** THE LOCK POWER SUPPLY UNIT REQUIRES A PULSE TO RELEASE OR UNLOCK

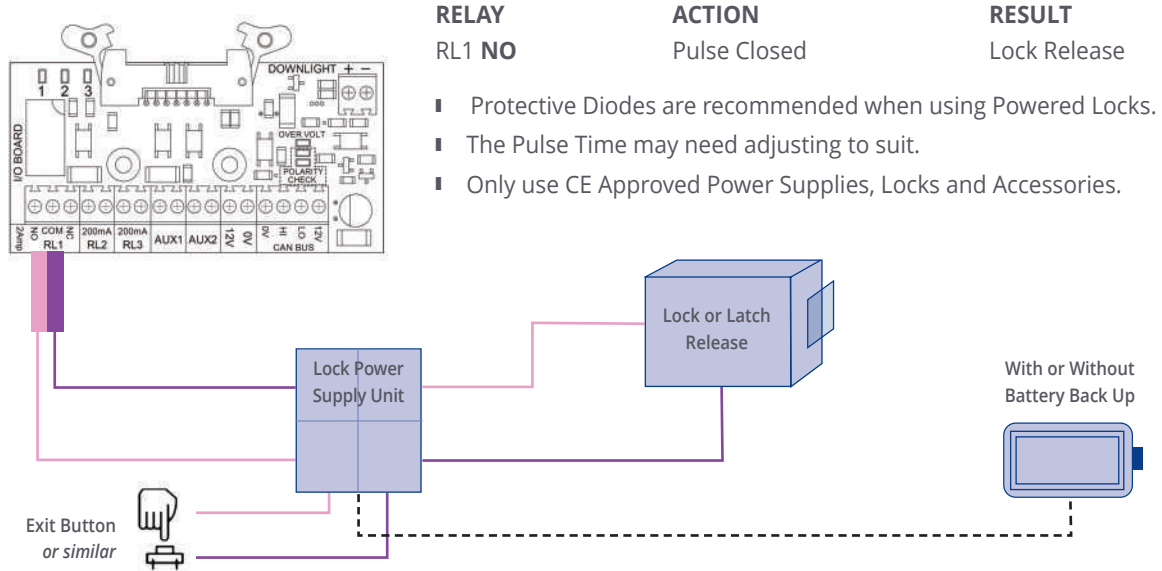

- Methods of Relay Operation can include: DTMF Tone / Facia PINS / Authorisation Recognition.
- Typical examples not common to all systems. Please follow the DHF Code of Practice Guide accordingly.

### EXAMPLE 5.0

**Application:** OPTIMUS TO A MAGNETIC LOCK OR PERMANENTLY ENERGISED LOCK

**Condition:** THE LOCK POWER UNIT REQUIRES TO BE UN-SWITCHED TO RELEASE THE LOCK - SUBJECT TO TYPE AND FAILURE STATUS

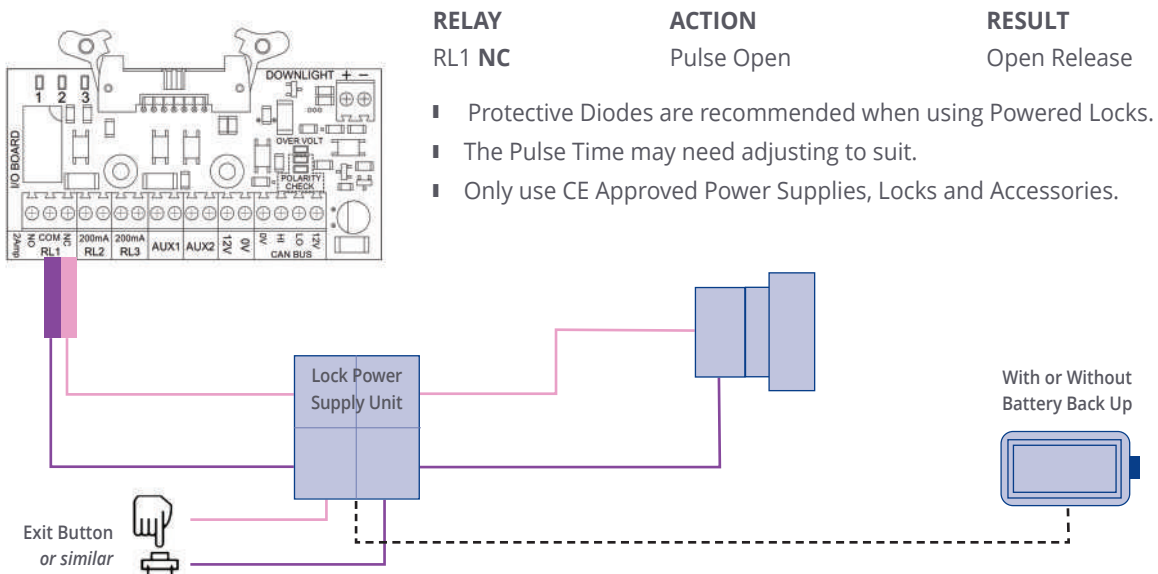

- Methods of Relay Operation can include: DTMF Tone / Facia PINS / Authorisation Recognition.
- Typical examples not common to all systems. Please follow the DHF Code of Practice Guide accordingly.

## APPLICATIONS AND CONNECTIONS

### EXAMPLE 6.0

**Application:** ALTERNATIVE EXIT CONTROL USING AUXILIARY INPUT  
**Condition:** AUXILIARY INPUT TO ACTIVATE SET RELAY. EXAMPLE: PUSH TO EXIT

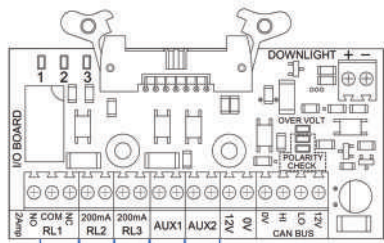

**RELAY**  
AUX 1 or 2

**ACTION**  
Pulse Close >70ms **NO**

**RESULT**  
Activates Relay of choice (RL1, RL2, RL3) as set up in the Programming

Either Aux 1 or Aux 2 as determined by Programming

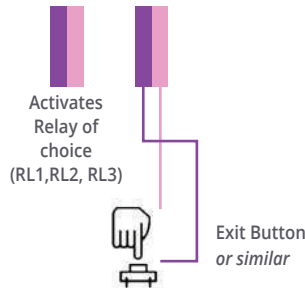

- Methods of Relay Operation can include: DTMF Tone / Facia PINS / Authorisation Recognition.
- Typical examples not common to all systems. Please follow the DHF Code of Practice Guide accordingly.
- The Auxiliary inputs are for volt free exit release type buttons only. Damage will result if feeding voltage or any other item that is not a volt free contact

### INSTALLING OR REPLACING THE SIM CARD

Ensure that the Unit is switched off at the plug before inserting or removing the micro SIM card.

When the micro SIM card is inserted CORRECTLY:

1. The Green "OK" LED is dual purpose
  - a. It will illuminate indicating that power is being received by the PCB
  - b. It will indicate the signal strength (RSSI) through a number of slow flashes:
    - i. 1 Flash = 1 Bar.
    - ii. Max 4 Flashes = 4 Bars.
2. The Blue "Network Status" LED will indicate connection status:
  - a. Off = Disconnected.
  - b. On solid = Connecting to the Network,  
*followed by:*
  - c. Slow Flashing = Connected.

Should the micro SIM be inserted INCORRECTLY or not detected?

1. The Green "OK" LED will slow flash for approximately 20 seconds, then fast flash.
2. The Blue "Network Status" LED will be permanently On.

## PROGRAMMABLE SETTINGS 'COMMTEL CONFIG' APP + ADDITIONAL MANUAL SMS COMMANDS

There are several Factory Default Settings that cannot be changed.

### CONFIGURABLE SETTINGS

These allow local customisation of the Intercom, typically by the Installer:

1. Addition, configuration and alteration of
  - a. Call Point including Follow-On Phone numbers.
  - b. Pin Codes.
  - c. Authorised Incoming Phone numbers and Command settings.
2. Renaming Relays.
3. Activate Time Periods and Trade Button.
4. Utilising Auxiliaries.
5. Manage SMS alerts.

**Please note:** Auxiliary 1 and Auxiliary 2 Inputs are factory set as Inputs only and cannot be changed to Outputs.

The Settings and Features are programmed using Commtel CONFIG App and additional manual SMS Commands.

## INTERNAL CELL REPLACEMENT FOR REAL TIME CLOCK (RTC)

The Intercom is fitted with 3V Lithium cell CR1220, which provides backup to preserve Time and Date within the RTC during power down.

The 3 Volt Lithium cell CR1220 is mounted on the 4G PRO in a holder, this allows the cell to be changed, if/when needed.

For reference, the RTC has an accuracy of +/- 1.5mins per year.

The life of the cell is approximately 1 year if the 4G PRO Board is left un-powered.

A continuously powered up 4G PRO would allow the cell to achieve a shelf life of 10 years min.

### REPLACING THE LITHIUM CELL

**CAUTION: RISK OF EXPLOSION IF THE CELL IS REPLACED BY AN INCORRECT TYPE. THE CORRECT TYPE IS LITHIUM CELL CR1220.**

To Replace the Cell:

1. Replacing the cell is necessary when it is close to exhaustion, which can be identified when the Cell voltage reaches 2.7V, measured with a digital meter across the legs of the holder.

To Change the Cell:

2. Keeping the board powered will not lose any date/time settings.
3. If the cell is exhausted and Date / Time are wrong, there is no need to power up the board prior to replacing the cell.
4. Check and / or reset the date / time through SMS Short Command Programming Guide.

Method:

1. Press the side of the cell through the slot in the holder with a slight upward bias using a small flat bladed screwdriver or the edge of an old SIM card, the cell will pop out. Do not lever the cell out.
2. Slide the new cell into the holder.
3. On the old cell there is a yellow sticker, remove this and fit over the new cell and holder.
4. Do not put the yellow sticker on the new cell first as it may not make proper contact with the holder.
5. The yellow sticker is there to protect the top of the cell which is the positive terminal and minimises the risk of any metallic objects touching it.

Please dispose of or recycle the exhausted cell in a responsible way and according to the Cell manufacturer's instructions.

If storing un-powered 4G PRO boards for an extended time, Optimus recommends that the cell is removed until the board is needed.



## EU CE DECLARATION OF CONFORMITY AND RADIO EQUIPMENT DIRECTIVE

This can be found at [www.commtel.io](http://www.commtel.io)



COMMTEL LTD, ORCHARD HOUSE, 39 GATWICK ROAD  
CRAWLEY, WEST SUSSEX RH10 9RB

TELEPHONE: 01306 710120    EMAIL: [info@optimus-uk.com](mailto:info@optimus-uk.com)

[www.optimus-uk.com](http://www.optimus-uk.com)

